

*The perfect mix!
Price, Quality, Versatility*

STD - StandardFLEX - OK

Morse e Cubi / Vises & Vise Towers

INDICE - INDEX

pages		pages		pages		pages		pages	
Art.	1.	Art.	1.	Art.	1.	Art.	1.	Art.	1.
1	8	218	12 - 16	672G	48				
1A	20	230B	20 - 22	672H	48				
1AE	20	230E	20 - 22	672I	48				
1AZ	22	230F	20 - 22	672J	48				
1AZE	22	242G	8 - 10	700	28				
1E	8	243G	12	701	30				
1Z	10	246	14	750	28				
1ZE	10	246G	14	828A	30				
12	12	247	16	981	3				
12E	12	247G	16	985	3				
14	14	296	6	DIVIGER	38				
14E	14	313	8 - 10 - 14	205					
15	16	313R	12 - 16	DPG250	36				
15E	16	450	30						
40	24	666	46						
40A	24	666A	47						
40Z	24	666AS	47						
62	24	666B	47						
62K	37 - 39	666BS	47						
81P	24	666C	47						
99A	37 - 39	666CS	47						
99B	37 - 39	666D	47						
99H	37 - 39	666DS	47						
99S	37 - 39	666E	47						
99T	37 - 39	666ES	47						
130	34	666F	47						
130S	34	666FS	47						
131	34	666G	47						
131A	34	666GS	47						
131AS	34	666H	47						
131S	34	666HS	47						
136	34	666I	47						
136S	34	666IS	47						
137	34	666L	47						
137S	34	666LS	47						
138	34	666M	47						
138D	34	666MS	47						
138DS	34	666N	47						
138S	34	666NS	47						
139	34	666O	45						
139D	34	666OS	47						
139DS	34	666S	46						
139S	34	667	49						
150	34	668	49						
150A	34	672	48						
150AS	34	672A	48						
150S	34	672B	48						
212	8 - 10 - 14 - 20 - 22	672C	48						
213	12	672D	48						
217	8 - 10	672E	48						
		672F	48						

VALIGETTA DI CAMPIONATURA STD / StdFLEX

SAMPLE KIT CASE STD / StdFLEX

Art. 981

Morsa / Vise Art. 1

Cod. 0.98.10000

Art. 1 - All'Interno - Inside:

Art. 985

Morsa / Vise Art. 1A

Cod. 0.98.50000

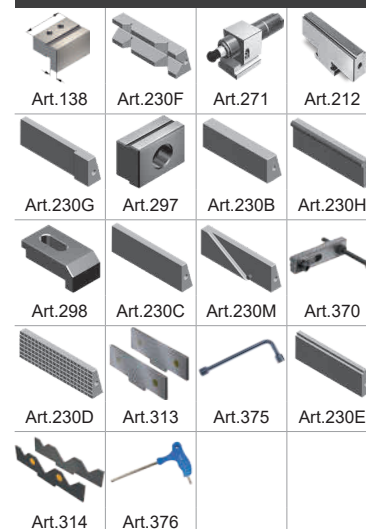
Art. 1 - All'Interno - Inside:

SIMBOLOGIA DATI TECNICI

TECHNICAL DATA ICONS

GANASCE JAWS							POSSIBILITÀ POSSIBILITY					
	Fissa Fixed	Mobile Movable	Intermedia Intermediate	Fissa con piastra singola Fixed with single plate	Fissa con piastra doppia Fixed with double plate	Ganasce sovrapponibili Stack Type Jaws		Montaggio sul fianco o in serie Side mounting or gang operation	Predisposizione Zero Point Zero Point ready	Cubi-morsa Vise tower	Divisore Automatico Automatic dividing head	Divisore Meccanico Mechanical dividing head
PIASTRE GANASCE JAW PLATES						PAGINE PAGES						
	Discendente Pull down	Piana Straight	Cambio rapido manuale Quick manual change	GRIP integrale integral GRIP	Inseri GRIP GRIP Inserts		Accessori & Ricambi Accessories & Spare Parts	Istruzioni corretto utilizzo Instruction for a proper use	Diagrammi forze di serraggio Clamping force diagrams	Sistema Idraulico Hydraulic System		

OPZIONI LAVORAZIONI EXTRA

OPTIONS FOR EXTRA MACHINING

 Nei codici, **STD** si riferisce agli articoli dei gruppi 1, 2 e 3.
 In codes, **STD** refers to articles in groups 1, 2 and 3.

Lavorazione extra Extra machining	Cod.	Lavorazione extra Extra machining	Cod.
AGGIUNTA di un foro calibrato ADDITION of a calibrated hole	MAN-010-STD	MONTAGGIO SEMPLICE SIMPLE ASSEMBLY	MAN-060-STD
AGGIUNTA di una chiave calibrata ADDITION of a calibrated key-way	MAN-020-STD	MONTAGGIO ed ALLINEAMENTO (Standard) (Standard) ASSEMBLY and ALIGNMENT	MAN-070-STD
PREDISPOSIZIONE SEMPLICE SIMPLE SET UP	MAN-030-STD	MONTAGGIO VERTICALE COMPLETE VERTICAL ASSEMBLY	MAN-080-STD
PREDISPOSIZIONE & MONTAGGIO COMPLETO COMPLETE SET UP & MOUNTING	MAN-040-STD	ALLINEAMENTO e CONTROLLO tramite DEA ALIGNMENT and CONTROL by DEA \ CMM	MAN-090-STD
MONTAGGIO PARZIALE PARTIAL ASSEMBLY	MAN-050-STD	TABULATO controllo DEA PRINTOUT DEA control	MAN-100-STD

Vedi pagina 1.40 per esempi applicativi - See page 1.40 for application examples

Morse e Cubi / Vises & Vise Towers

STANDARD



Precisione / Accuracy
 $\pm 0,02\text{mm}$



Durezza / Hardened
HRC 58 \pm 2

La morsa più diffusa al mondo!

The most popular and copied vise in the world!

USURA INESISTENTE / NO WEAR

Grazie all'accurata scelta dei materiali impiegati ed allo studio dimensionale computerizzato dei componenti. Costruzione completamente in speciali leghe di acciaio ad alta resistenza, normalizzato, cementato e temprato con durezza 58 \pm 2 HRC. Tutto ciò al fine di conferire massima rigidità, elevate prestazioni e usura inesistente. A riprova di tutto ciò assicuriamo **5 ANNI DI GARANZIA** su tutto il programma morse e organi meccanici in genere.

Thanks to the manufacturing with only the most suitable materials and to the structure of the vise components (developed using computer customised softwares and the experience gained during many years spent working on the specific field). High alloyed quality resistance steel, case hardened HRC 58 \pm 2, is used in manufacturing all the Gerardi vises and accessories in order to give maximum rigidity, high performances and no wear. As evidence we give **5 YEARS WARRANTY** on all the vises and mechanical components

MODULARITÀ / MODULARITY

Tutte le morse ed accessori sono elementi componibili, intercambiabili e perfettamente allineabili fra loro e con i quali è possibile ottenere differenti soluzioni di bloccaggio. Secondo tale principio l'unico elemento che differenzia le attrezzature con identica larghezza di presa è la base (la cui lunghezza determina la massima apertura della morsa), mentre gli altri componenti sono identici. Mediante l'aggiunta o semplice sostituzione di alcuni particolari si può variare la tipologia di bloccaggio secondo le proprie esigenze utilizzando la stessa attrezzatura acquistata in un primo momento (bloccaggi singoli, con base girevole, doppi, verticali, di pezzi piani, tondi, piatti e grezzi, manuali, idraulici o pneumatici).

All vises and accessories are modular and components of all our vises will interchange with perfect alignment to provide different workholding solutions. With this basic principle the only difference between fixtures with the same width of clamping is the base (whose length determines the maximum opening of the vise), while the rest of components have same dimensions. Through the simple addition or substitution of some particulars You can change the type of clamping as Your needs require using the same fixture purchased before (single clamping, swivel base, double, vertical, smooth or round or flat or rough workpieces, manual, hydraulic or pneumatic).

DESIGN COMPATTO / SPACE SAVING DESIGN

La semplicità nonché la compattezza costruttiva consentono un'apertura notevole rispetto all'ingombro totale dell'attrezzatura. Inoltre lo stesso peso (solo 25 kg per una morsa da 150 mm di larghezza ganas cia) è tale da consentire un facile trasferimento da una macchina all'altra.

The space saving design and solid construction allow a maximum blocking ratio to total overall dimension of the vise. Furthermore the weight (only 25 kg for a 150 mm jaw width vise) allows a simple moving from one machine to another.

SERRAGGI RAPIDI / QUICK CLAMPING

Grazie allo scorrimento del gruppo di serraggio nella guida della base (a cremagliera) fino in prossimità del pezzo da lavorare dove si adatterà automaticamente alla nicchia più vicina. L'operazione di serraggio si conclude agendo sulla vite di bloccaggio. Oltre a quello manuale meccanico, sono disponibili 4 ulteriori sistemi di serraggio intercambiabili e indipendenti: 1 - Idraulici / 2 - Pneumatici / 3 - Idraulici manuali / 4 - Idraulici elettrici. L'operazione è in termini di secondi.

Thanks to the clamping device sliding in the vise base slide (compact rack type) till the proximity of the workpiece. The clamping is completed with the main screw. Besides the manual mechanic system, 4 further interchangeable and independent clamping systems are available: 1- Hydraulic / 2- Pneumatic / 3- Manual hydraulic / 4- Electrical hydraulic. The change needs only few seconds.



Ganascia monoblocco
 Solid Guided Jaws

Entrambe le ganasce sono costruite in corpo unico (non esistono slitte o tasselli di fissaggio) per garantire una maggiore rigidità e nessuna flessione. Entrambe le piastre ganasce sono costruite con un **angolo di spinta verso il basso**. Ciò assicura, nel momento della chiusura, una trazione del pezzo contro la base della morsa (per trascinamento) e di conseguenza un bloccaggio sicuro e preciso.

Both jaws bodies are built in one solid piece (no slides or key-nuts): in order to guarantee higher rigidity & no bendings. Both jaw plates are manufactured with a **pull down angle**. This ensures, during the clamping operation, a downward run of the workpiece against the vise base (by dragging) and thus a precise and safety clamping

Ganascia prismatica
 Prismatic jaw

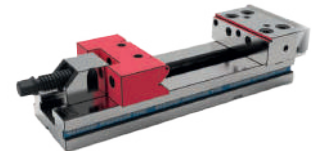

La ganascia prismatica Art.217 consente il serraggio e la lavorazione di particolari tondi in orizzontale e in verticale oppure il serraggio rialzato di particolari tramite il gradino.

The prismatic jaw Art.217 allows the clamping and machining of vertical and horizontal round workpieces or to clamp rised workpieces for drilled through on the step

Sovraganascia
 Stack type jaw

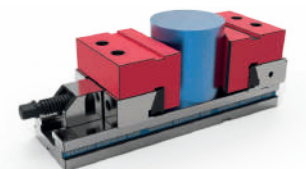

Quattro fori filettati supplementari sopra le ganasce danno la possibilità di installare ganasce sovrapponibili per applicazioni speciali.

4 extra tapped holes over the jaws for special Gerardi stack type jaw application

Coda di Rondine
 Dove Tail

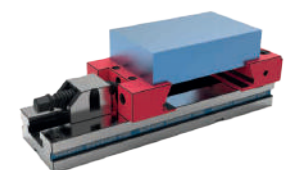

Rimuovendo le piastre ganasce è possibile sfruttare l'inclinazione a 15° del corpo per serrare il particolare, prelaborando la faccia inferiore del particolare ottenendo così un sistema ad incastro irreversibile.

By taking off the jaw plates, it is possible to exploit the body inclination of 15° to clamp the workpiece and pre-machine the lower surface thus obtaining an irreversible dovetail system.

La morsa componibile GERARDI è costruita con il concetto di intercambiabilità di tutti gli elementi componenti l'attrezzatura e con la certezza di poter usare più morse sulla stessa macchina con posizionamento ed allineamento perfetto in pochi secondi. Tutto ciò è possibile per l'elevato grado di precisione della morsa stessa ed in particolare per quanto riguarda: l'altezza della base, l'allineamento con tasselli di cava longitudinale rispetto alla ganasca fissa, la perpendicolarità della ganasca fissa rispetto alla base ed il parallelismo dei piani della base. Tali caratteristiche consentono di risolvere più svariati e complicati problemi di fissaggio in pochi istanti con l'uso di più morse.

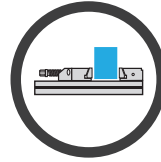

SCAN IT TO SEE



THE WEB PAGE



All GERARDI vises and accessories are modular and components of all our vises will interchange with perfect alignment. The vises can be matched side to side with the highest precision and minimum of set up times thanks to many fixed reference points. All this is possible thanks to the high precision of the vise particularly as regards: the base high, the alignment with longitudinal key-nuts with respect to the fixed jaw, the perpendicularity of the fixed jaw with respect to the vise base and the parallelism of the base top and bottom surfaces. Those features allows us to solve the most varied and complicated problems of clamping in a few seconds with the use of more vises.

Il trinomio perfetto!
Convenienza, Qualità, Versatilità

The perfect mix!
Price, Quality, Versatility

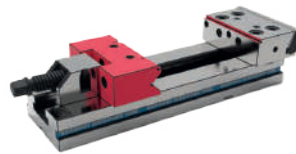

Versatility - Versatility

La ganasca fissa con gradino posteriore di 5x5 mm consente, una volta ruotata di 180°, il perfetto accoppiamento al gradino della ganasca prismatica mobile (Art.217) ordinabile separatamente: è così possibile il serraggio di pezzi piatti senza parallele e di tondi sia in orizzontale che in verticale. Inoltre è disponibile una vastissima gamma di ganasce nonché un sistema di parallele piane e angolari per le più svariate applicazioni e la lavorazione di pezzi di qualsiasi forma e dimensione. Illimitata gamma di aperture possibili.

Fixed jaw with 5x5mm step matchable to the prismatic movable jaw (Art.217 to be ordered separately) which allows to clamp plates without parallels and round workpieces vertical & horizontal way. Vertical, sideway and gang operation are possible with the appropriate components (column, narrow width jaws, etc.) Unlimited clamping range.

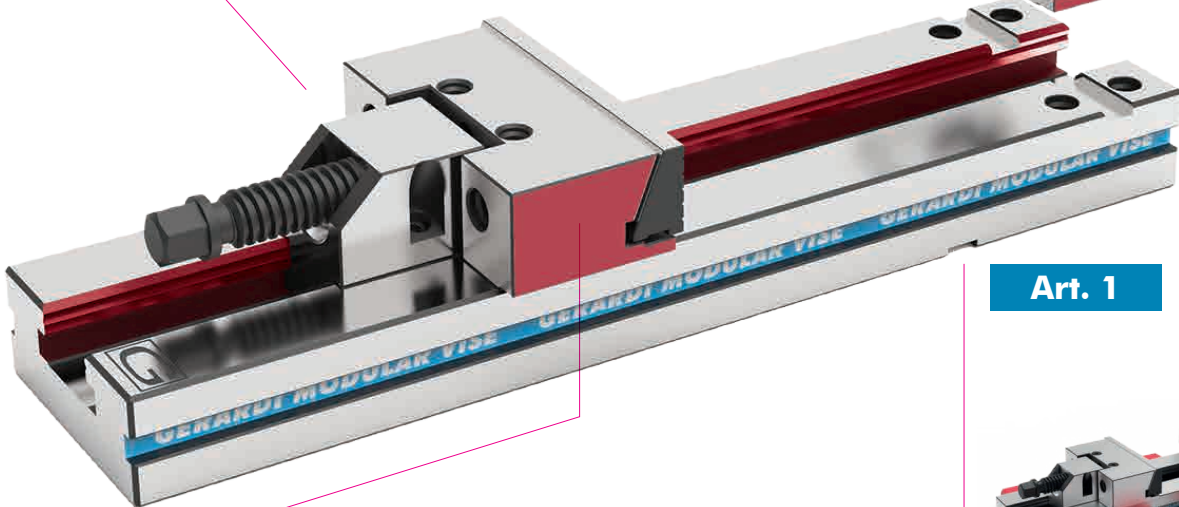
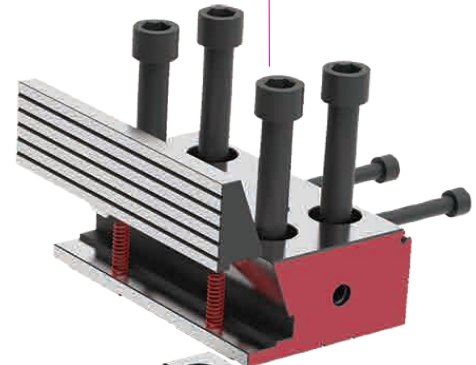

Art. 1

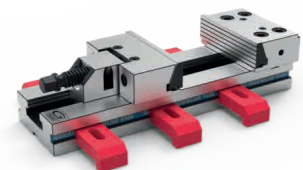

Precisione - Highest accuracies $\pm 0,02\text{mm}$

Slittone base con tutte le superfici di scorrimento ed accoppiamento rettificata. L'allineamento agli assi della macchina avviene grazie alle chiavette longitudinali e trasversali (16H7) o fori di posizionamento ($\varnothing 16\text{mm}$ F7), a richiesta, previsti sulla base di ciascuna morsa. Naturalmente tutto ciò consente oltre alle precisioni dichiarate tempi di installazione ristrettissimi.

Solid vise base. Every sliding and coupling surface is ground. Centesimal tolerances are guaranteed by checking cycles with CNC measuring machine. The perfect alignment with the machine axis is given by longitudinal and cross keyways (16H7) or positioning holes ($\varnothing 16\text{mm}$ F7), upon specific request, on the vise base. Of course this allows minimum of set up times and gang operations.

Staffe d'ancoraggio / Vise holding clamps

NEW
2024

Standard / StandardFLEX

Coppia staffe di fissaggio Art.296, complete di vite e dado a "T"

Pair of vise holding clamps Art.296 complete of screw and "T" nuts



Esempio d'ordine per morsa tipo 3 su macchina con cave a T da 18mm: **Art.296 T.3 X=18mm**

Oppure con codice: **2.29.6300 X=18mm**

Order example for Type 3 vise on machine with 18mm T-slots: **Art.296 T.3 X=18mm**

Also with code: **2.29.6300 X=18mm**

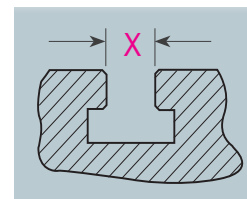
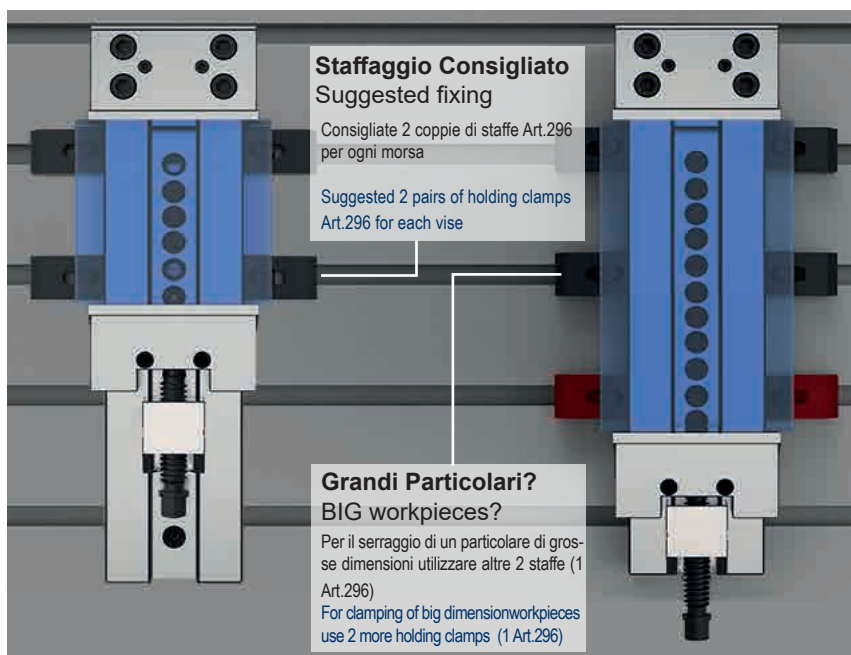

Cava a T

T Slot

Specificare sempre la cava della vostra macchina

Always specify the machine T-slot dimension

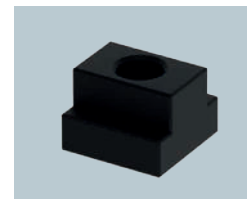

Art.287 (Pag.4.34)

Dadi a T - T Nuts

Per fissaggio morse alle cave a T della macchina

For vise clamping on the machine T-slots

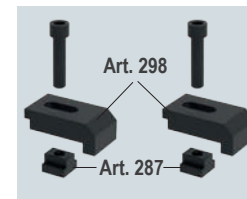

Art.296

(Art.298 + Art.287)

Consigliate 2 coppie di staffe Art.296 per ogni morsa

Suggested 2 pairs of holding clamps Art.296 for each vise

Tipo (grandezza) morsa Vise type (size)		1				1 - 2				3 - 4				5 - 6														
Art. 296 Coppia di staffe Holding clamps pair	Cava a T slot X	12	14	16	18	12*	14	16	18	20	18*	20	22	16	18	20	22	18*	20	22	16	18	20	22	18*	20	22	
	T-nuts Ref. N°	8	9	10	11	12	13	14	20	21	22	32	33	34	20	21	22	23	32	33	34	20	21	22	23	32	33	34
	Filetto vite Screw thread	M8				M10				M12 *				M16				M12 *				M16 *						
1 X M8 	A	50	50	50	50	76	76	86	86																			
	B	24	24	24	24	30	30	40	40																			
	C	6	6	6	6	6	6	10	10																			
	Ø D	8,5	11	13	17	13	17	13	17																			
	E	10	10	10	10	13	13	15	15																			
	Ø F	14	-	-	-	-	-	-	-																			
	G	14	16	17,5	19	17	16	26	26																			
	G1	17	15	13	9	22	15	27	27																			
	H	34	34	34	34	42	42	50	50																			
	I	8	10	10	10	-	-	-	-																			
	J	4	4	4	4	10	10	10	10																			
T ± 0,1	15	15	15	15	20	20	26	26																				
Cod.	2.29.61000 / M8	2.29.61000 / M10	2.29.61000 / M12	2.29.61000 / M16	2.29.63000 / M12	2.29.63000 / M12	2.29.65000 / M12	2.29.65000 / M16																				

* Scelta consigliata - Suggested choice

* Scelta **NON** consigliata - **NO** Suggested choice

Soluzioni personalizzate / Customized solutions

Standard / StandardFLEX

Soluzioni personalizzate a tutti i vostri problemi di serraggio

Customized solutions for all your clamping problems



Morse StandardMatic

StandardMatic vises

Morse Modulari di Precisione accoppiabili ed allineabili per serraggi multipli Pneumoidraulici (Serie StandardMatic)

Precision Modular vises matchable for gang operations and Pneumohydraulic clamping (StandardMatic series)



Modularità & versatilità

Modularity & versatility

Morsa STD con ganasce lavorabili montata in orizzontale su un centro di lavoro verticale.

Std vise with machineable jaws horizontally mounted on vertical machining centres.

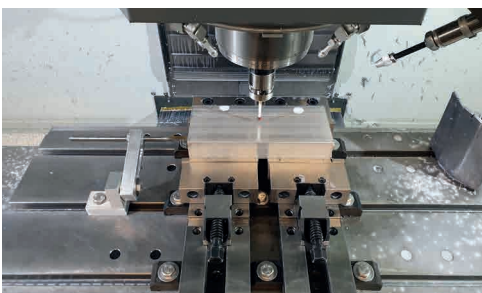

Morse modulari di precisione

Precision modular vises

Morse modulari di precisione allineate per il serraggio di un particolare di grandi dimensioni.

Precision modular vises aligned for rather big workpiece clamping



Ganasce monoblocco guidate

Solid Guided jaws

Ganasce guidate monoblocco costruite con un angolo di spinta verso il basso

Guided movable jaws built in one solid body with a pull down angle



Usura inesistente

No wear

Costruzione in speciali leghe di acciaio ad alta resistenza, normalizzato, cementato e temprato con durezza 60 ±2 HRC

High alloyed quality resistance steel, case hardened HRC 60±2

Tipo (grandezza) morsa / Vise type (size)	kN	1	2	3		4			
		16 kN	25 kN	30 kN		30 kN			
Apertura massima / Maximum spread	A	100	150	200	300	200	300	400	500
	W	100	125	150		175			
	B	30	40	50		60			
	C	35	40	50		58			
	D	270	345	420	520	455	555	655	755
	G	75	95	125		145			
	kg	6.8	12.9	25.5	29	37	42	47	52
	Cod.	3.01.00000	3.02.10000	3.03.20000	3.03.30000	3.04.20000	3.04.30000	3.04.40000	3.04.50000

Art. 1

Morsa modulare di precisione STD con ganaschia mobile monoblocco guidata

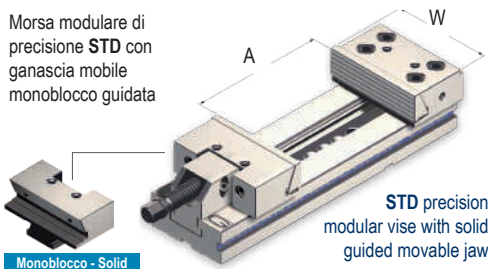

STD precision modular vise with solid guided movable jaw

Monoblocco - Solid

AMPLIA LE TUE APPLICAZIONI TRAMITE GLI ACCESSORI MODULARI !

Art. 313

Parallele magnetiche
Magnetic parallel plates

Vedi pagina 4.27 per altezze disponibili
See page 4.27 for available height

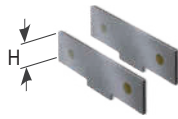

Cod.	4.31.3100C	4.31.3200C	4.31.3300C	4.31.3400C
H	23	33	43	53

Art. 212

Ganaschia mobile intermedia
(da usare con Art. 313)

Intermediate movable jaw (to be used with Art. 313)

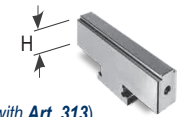

Cod.	1.21.21000	1.21.22000	1.21.23000	1.21.24000
------	------------	------------	------------	------------

Art. 217

Ganaschia mobile prismatica
Prismatic movable jaw



Cod.	2.21.71000	2.21.72000	2.21.73000	2.21.74000
------	------------	------------	------------	------------

Art. 242G

Piastra ganaschia con inserti GRIP completa di parallela magnetica
Jaw plate with GRIP inserts with magnetic parallel



Cod.	1.24.2G100	1.24.2G200	1.24.2G300	1.24.2G400
------	------------	------------	------------	------------

Art. 1E

NEW 2024

Morsa modulare StandardMatic con cilindro idraulico a SINGOLO effetto

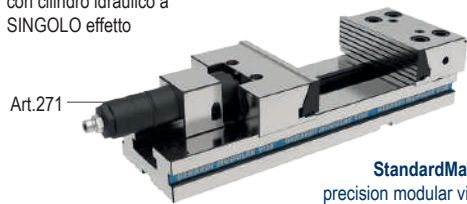

StandardMatic precision modular vise with SINGLE effect hydraulic cylinder

Cod.	Vedi pag. 4.40 - 4.41 - See pag. 4.40 - 4.41			
------	--	--	--	--

MORSE StandardMatic

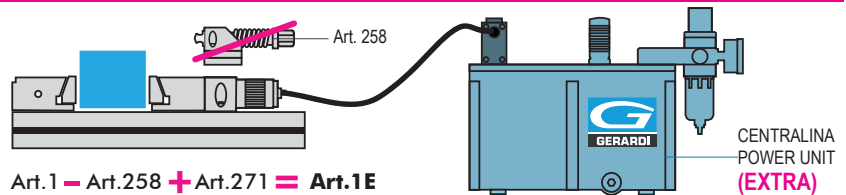

Dotazione standard:

- 1 arresto laterale Art. 370
- 1 coppia di tasselli di posizionamento per cava da 16 mm Art. 297
- 1 chiave a pipa Art. 375 ■ 1 chiave a "T" Art. 376

Extra per ogni foro calibrato (tolleranza F7) - MAN-010-STD

Extra per ogni chiavevitta (tolleranza H7) - MAN-020-STD

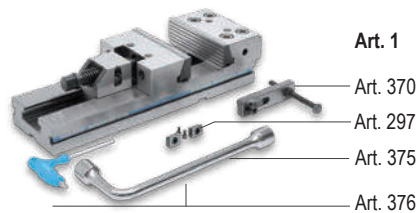

Standard equipment:

- 1 workstop Art. 370
- 1 pair of positioning key-nuts for 16 mm slot Art. 297
- 1 box wrench Art. 375 ■ 1 T-wrench Art. 376

Extra charge for each calibrated hole (F7 tolerance) - MAN-010-STD

Extra charge for each calibrated key nut (F7 tolerance) - MAN-020-STD

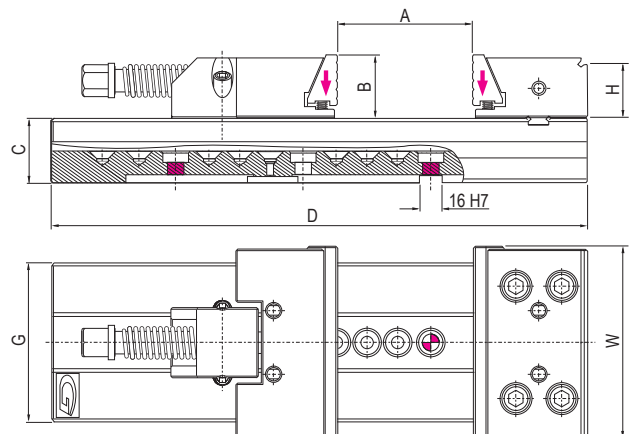

Vedi gruppo 4 per gamma completa accessori
See group 4 for complete range of accessories

	5 40 kN					6 40 kN						
A	200	300	400	500	600	200	300	400	500	600	700	800
W	200					300						
B	65					80						
C	70					78						
D	495	595	695	795	895	535	635	735	835	935	1035	1135
G	170					195						
kg	64	69	74	79	84	95	105	115	125	135	145	155
Cod.	3.05.20000	3.05.30000	3.05.40000	3.05.50000	3.05.60000	3.06.20000	3.06.30000	3.06.40000	3.06.50000	3.06.60000	3.06.70000	3.06.80000

UPGRADE YOUR VISE APPLICATIONS THROUGH MODULAR ACCESSORIES !

4.31.3500C

Art. 313

53



4.31.3600C

68

1.21.25000

Art. 212

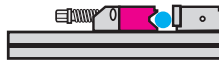

1.21.26000

2.21.75000

Art. 217

2.21.76000

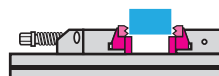
1.24.2G500

Art. 242G

1.24.2G600

Cod.

Vedi pag. 4.40 - 4.41 - See pag. 4.40 - 4.41

StandardMatic VISES

Centralina Pneumoidraulica Art.393/394/395 (EXTRA)
 Pneumohydraulic Power Unit Art.393/394/395 (EXTRA)

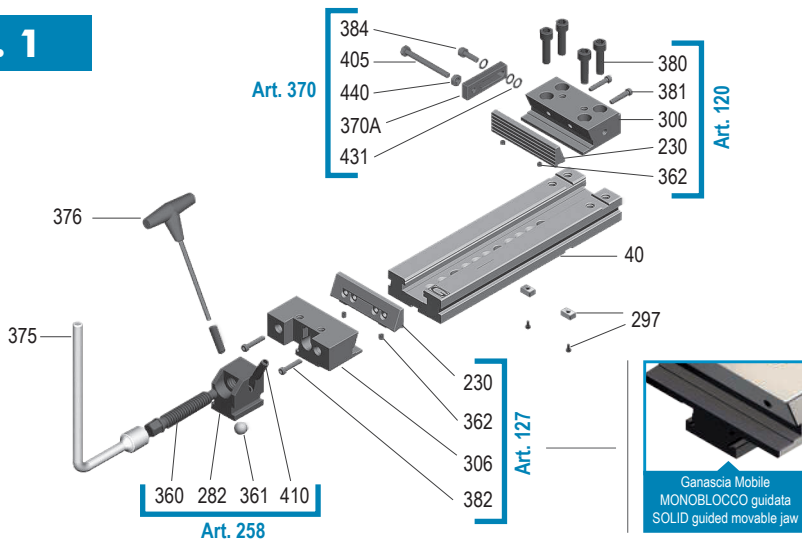
Art. 1

Art.	Pag.	Art.	Pag.
40	1.24	376	4.35
230	4.9	380	4.28
282	4.36	381	4.28
297	4.34	382	4.28
300	4.29	384	4.28
306	4.29	405	4.35
360	4.36	410	4.36
361	4.36	431	4.28
362	4.28	440	4.28
370A	4.35	-	-
375	4.35	-	-

Tipo (grandezza) morsa / Vise type (size)

	kN	1* 16 kN	2 25 kN	3 30 kN		4 30 kN			
Apertura massima / Maximum spread	A	100	150	200	300	200	300	400	500
Art. 1Z	W	100	125	150		175			
	B	30	40	50		60			
	C	35	40	50		58			
	D	270	345	420	520	455	555	655	755
	G	75	95	125		145			
	kg	7.3	13.2	26.2	29.7	37.9	43	48.1	53.2
	Cod.	1.1Z.10000	1.1Z.20000	1.1Z.32000	1.1Z.33000	1.1Z.42000	1.1Z.43000	1.1Z.44000	1.1Z.45000

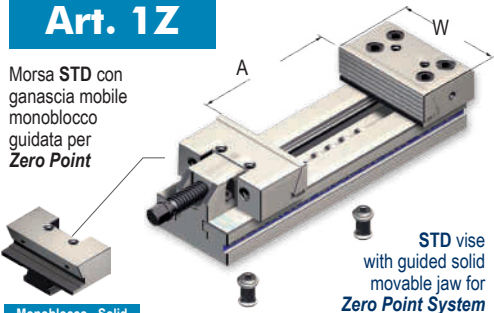

Monoblocco - Solid

AMPLIA LE TUE APPLICAZIONI TRAMITE GLI ACCESSORI MODULARI !
Art. 313

 Parallele magnetiche
 Magnetic parallel plates

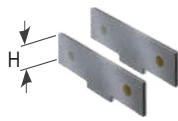
 Vedi pagina 4.27 per altezze disponibili
 See page 4.27 for available height

Cod. 4.31.3100C 4.31.3200C 4.31.3300C 4.31.3400C

H 23 33 43 53

Art. 212

 Ganascia mobile intermedia
 (da usare con Art. 313)

Intermediate movable jaw (to be used with Art. 313)



Cod. 1.21.21000 1.21.22000 1.21.23000 1.21.24000

Art. 217

 Ganascia mobile prismatica
 Prismatic movable jaw



Cod. 2.21.71000 2.21.72000 2.21.73000 2.21.74000

Art. 242G

 Piastra ganascia con inserti GRIP
 completa di parallela magnetica
 Jaw plate with GRIP inserts with magnetic parallel

Cod. 1.24.2G100 1.24.2G200 1.24.2G300 1.24.2G400

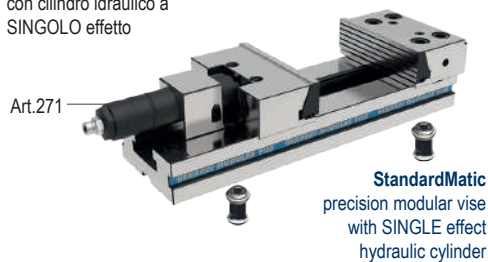
Art. 1ZE
NEW 2024

 Morsa modulare StandardMatic
 con cilindro idraulico a
 SINGOLO effetto

StandardMatic
 precision modular vise
 with SINGLE effect
 hydraulic cylinder

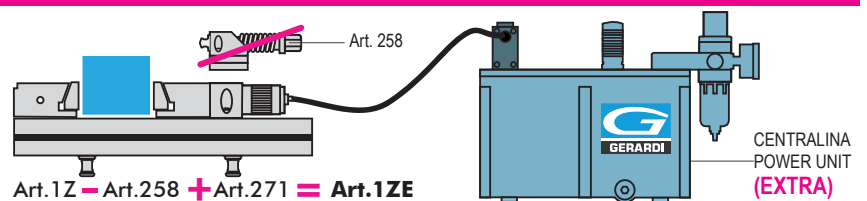
Cod. Vedi pag. 4.40 - 4.41 - See pag. 4.40 - 4.41

MORSE StandardMatic

Dotazione standard:

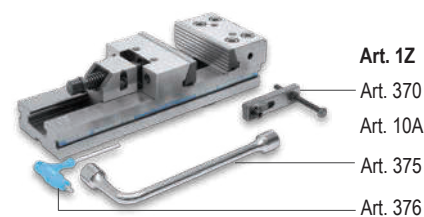
- 1 arresto laterale Art. 370
- 2 tiranti Art. 10A
- 1 chiave a pipa Art. 375
- 1 chiave a "T" Art. 376



Standard equipment:

- 1 workshop Art. 370
- 2 pullstuds Art. 10A
- 1 box wrench Art. 375
- 1 T-wrench Art. 376

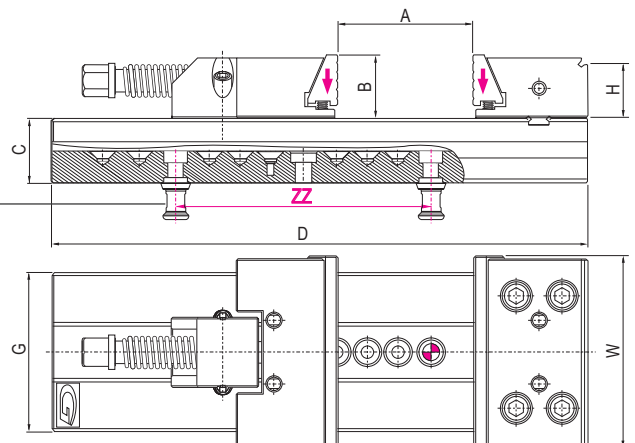

* Per morsa Tipo 1 sedi per tiranti 10A (tipo1) con interasse dei fori 150mm - Quote interassi tiranti ZZ a pag.1.24

For Vise T.1 - 10A pull studs positioning holes (T.1) with 150mm pitch - See on pag. 1.24 for pull studs pitches ZZ

 Vedi gruppo 4 per gamma completa accessori
 See group 4 for complete range of accessories

	5 40 kN					6 40 kN						
A	200	300	400	500	600	200	300	400	500	600	700	800
W	200					300						
B	65					80						
C	70					78						
D	495	595	695	795	895	535	635	735	835	935	1035	1135
G	170					195						
kg	65.3	70.3	75.3	80.3	85.3	97	107	117	127	137	147	157
Cod.	1.1Z.52000	1.1Z.53000	1.1Z.54000	1.1Z.55000	1.1Z.56000	1.1Z.62000	1.1Z.63000	1.1Z.64000	1.1Z.65000	1.1Z.66000	1.1Z.67000	1.1Z.68000

UPGRADE YOUR VISE APPLICATIONS THROUGH MODULAR ACCESSORIES !

4.31.3500C Art. 313 53		4.31.3600C 68
1.21.25000 Art. 212		1.21.26000
2.21.75000 Art. 217		2.21.76000
1.24.2G500 Art. 242G		1.24.2G600
Cod.	Vedi pag. 4.40 - 4.41 - See pag. 4.40 - 4.41	

StandardMatic VISES

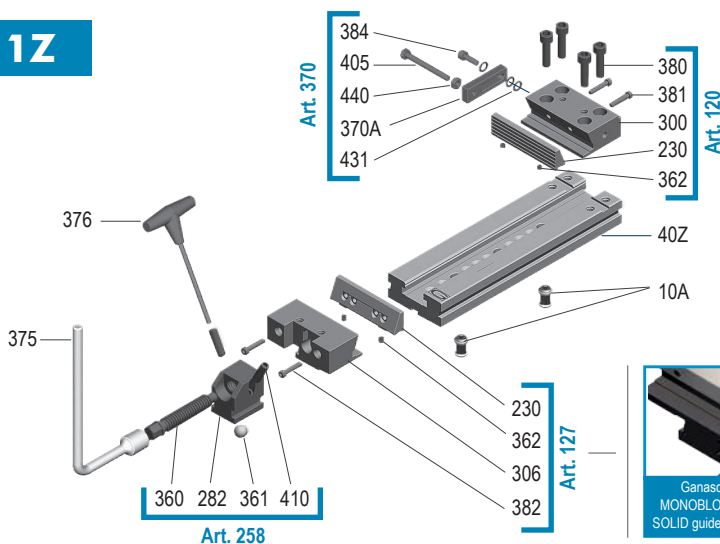

Centralina Pneumoidraulica Art.393/394/395 (EXTRA)
 Pneumohydraulic Power Unit Art.393/394/395 (EXTRA)

Art. 1Z

Art.	Pag.	Art.	Pag.
10A	9.31	376	4.35
40Z	1.24	380	4.28
230	4.9	381	4.28
282	4.36	382	4.28
300	4.29	384	4.28
306	4.29	405	4.35
360	4.36	410	4.36
361	4.36	431	4.28
362	4.28	440	4.28
370A	4.35	-	-
375	4.35	-	-

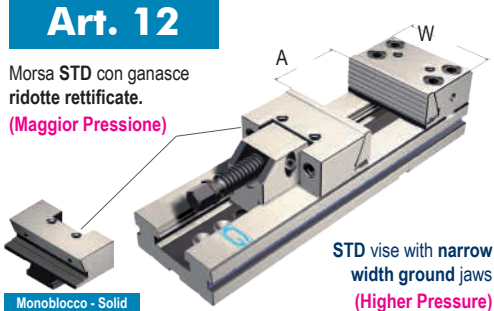

Tipo (grandezza) morsa / Vise type (size)	kN	1	2	3		4			
		16 kN	25 kN	30 kN		30 kN			
Apertura massima / Maximum spread	A	100	150	200	300	200	300	400	500
Art. 12 Morsa STD con ganasce ridotte rettificate. (Maggior Pressione)	W	75	95	125		145			
	B	30	40	50		60			
	C	35	40	50		58			
	D	270	345	420	520	455	555	655	755
	G	75	95	125		145			
kg		6.2	11.9	24.2	27.8	35	39	46	51
Cod.		3.01.00120	3.02.10120	3.03.20120	3.03.30120	3.04.20120	3.04.30120	3.04.40120	3.04.50120



Monoblocco - Solid

STD vise with narrow width ground jaws (Higher Pressure)

AMPLIA LE TUE APPLICAZIONI TRAMITE GLI ACCESSORI MODULARI !

Art. 313R Parallele magnetiche Magnetic parallel plates	Cod.	4.31.3R10C	4.31.3R20C	4.31.3R30C	4.31.3R40C
Vedi pagina 4.27 per altezze disponibili See page 4.27 for available height	H	23	33	43	53

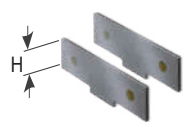

Art. 213 Ganascia mobile intermedia (da usare con Art. 313R) Intermediate movable jaw (to be used with Art. 313R)	Cod.	1.21.31000	1.21.32000	1.21.33000	1.21.34000
	H				



Art. 218 Ganascia mobile prismatica Prismatic movable jaw	Cod.	2.21.81000	2.21.82000	2.21.83000	2.21.84000



Art. 243G Piastra ganascia ridotta con inserti GRIP completa di parallela magnetica Narrow width jaw plate with GRIP inserts with magnetic parallel	Cod.	1.24.3G100	1.24.3G200	1.24.3G300	1.24.3G400



Art. 12E NEW 2024	Cod.	Vedi pag. 4.40 - 4.41 - See pag. 4.40 - 4.41			
Morsa modulare StandardMatic con cilindro idraulico a SINGOLO effetto					

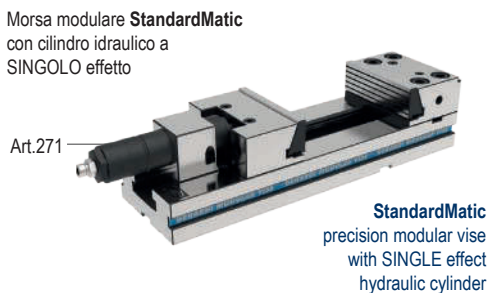

StandardMatic precision modular vise with SINGLE effect hydraulic cylinder

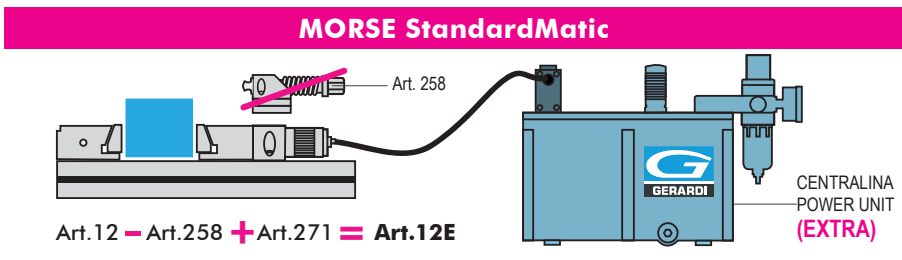

- Dotazione standard:
- 1 arresto laterale Art. 370
 - 1 coppia di tasselli di posizionamento per cava da 16 mm Art. 297
 - 1 chiave a pipa Art. 375 ■ 1 chiave a "T" Art. 376
- Extra per ogni foro calibrato (tolleranza F7) - MAN-010-STD
 Extra per ogni chiave a T (tolleranza H7) - MAN-020-STD

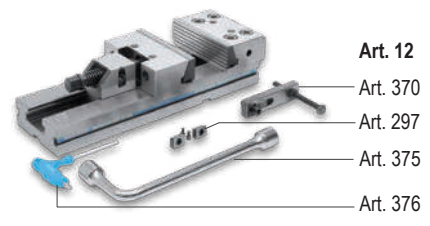

- Standard equipment:
- 1 workstop Art. 370
 - 1 pair of positioning key-nuts for 16 mm slot Art. 297
 - 1 box wrench Art. 375 ■ 1 T-wrench Art. 376
- Extra charge for each calibrated hole (F7 tolerance) - MAN-010-STD
 Extra charge for each calibrated key nut (F7 tolerance) - MAN-020-STD

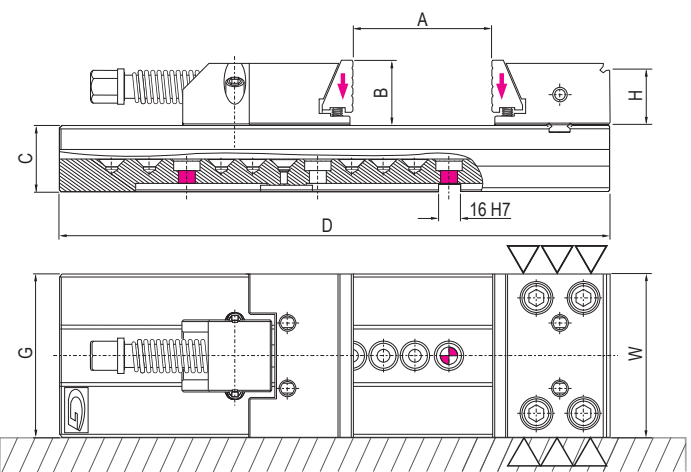
 Vedi gruppo 4 per gamma completa accessori
 See group 4 for complete range of accessories

	5 40 kN					6 40 kN						
A	200	300	400	500	600	200	300	400	500	600	700	800
W	170					195						
B	65					80						
C	70					78						
D	495	595	695	795	895	535	635	735	835	935	1035	1135
G	170					195						
kg	62	67	72	77	82	88	98	108	118	128	138	148
Cod.	3.05.20120	3.05.30120	3.05.40120	3.05.50120	3.05.60120	3.06.20120	3.06.30120	3.06.40120	3.06.50120	3.06.60120	3.06.70120	3.06.80120

UPGRADE YOUR VISE APPLICATIONS THROUGH MODULAR ACCESSORIES !

4.31.3R50C			4.31.3R60C									
Art. 313R	53			68								
1.21.35000			1.21.36000									
Art. 213												
2.21.85000			2.21.86000									
Art. 218												
1.24.3G500			1.24.3G600									
Art. 243G												
Cod.	Vedi pag. 4.40 - 4.41 - See pag. 4.40 - 4.41											

StandardMatic VISES

Centralina Pneumoidraulica Art.393/394/395 (EXTRA)
 Pneumohydraulic Power Unit Art.393/394/395 (EXTRA)

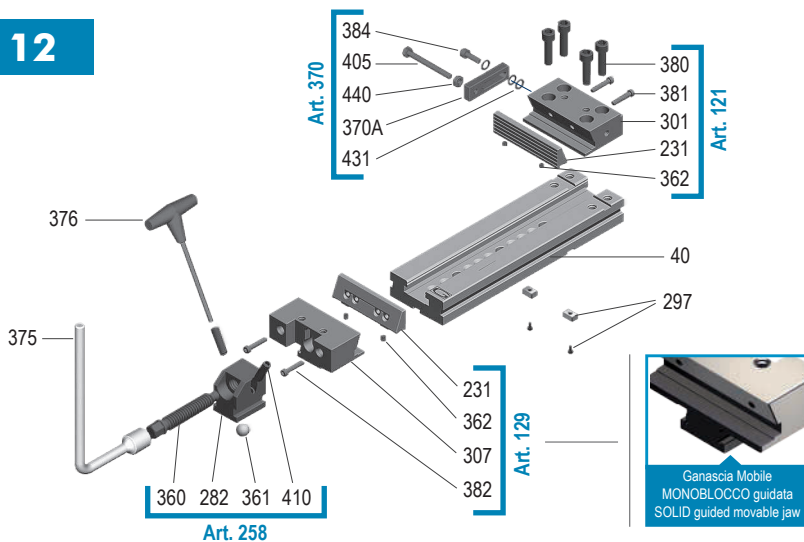
Art. 12

Art.	Pag.	Art.	Pag.
40	1.24	376	4.35
231	4.9	380	4.28
282	4.36	381	4.28
297	4.34	382	4.28
301	4.29	384	4.28
307	4.29	405	4.35
360	4.36	410	4.36
361	4.36	431	4.28
362	4.28	440	4.28
370A	4.35	-	-
375	4.35	-	-



Tipo (grandezza) morsa / Vise type (size)	kN	1		2		3		4	
		16 kN	25 kN	30 kN	30 kN	30 kN	30 kN	30 kN	
Apertura massima / Maximum spread	A	100	150	200	300	200	300	400	500
Art. 14 Morsa STD con ganasce a piastre piane Monoblocco - Solid	W	100	125	150		175			
	B	30	40	50		60			
	C	35	40	50		58			
	D	270	345	420	520	455	555	655	755
	G	75	95	125		145			
	kg	6.8	12.9	25.5	29	37	42	47	52
	Cod.	1.14.10000	1.14.20000	1.14.32000	1.14.33000	1.14.42000	1.14.43000	1.14.44000	1.14.45000

AMPLIA LE TUE APPLICAZIONI TRAMITE GLI ACCESSORI MODULARI !

Art. 313 Parallele magnetiche Magnetic parallel plates Vedi pagina 4.27 per altezze disponibili See page 4.27 for available height	Cod.		4.31.3100C		4.31.3200C		4.31.3300C		4.31.3400C	
	H	23	33	43		53				

Art. 212 Ganascia mobile intermedia (da usare con Art. 313) Intermediate movable jaw (to be used with Art. 313)	Cod.		1.21.21000		1.21.22000		1.21.23000		1.21.24000	
	H									

Art. 246 Piastra piana in acciaio lavorabile Machinable steel straight jaw plate	Cod.		1.65.16200		1.65.26200		1.65.36200		1.65.46200	

Art. 246G Piastra ganascia con inserti GRIP completa di parallela magnetica Jaw plate with GRIP inserts with magnetic parallel	Cod.		1.24.6G100		1.24.6G200		1.24.6G300		1.24.6G400	

Art. 14E Morsa modulare StandardMatic con cilindro idraulico a SINGOLO effetto NEW 2024	Cod.		Vedi pag. 4.40 - 4.41 - See pag. 4.40 - 4.41							

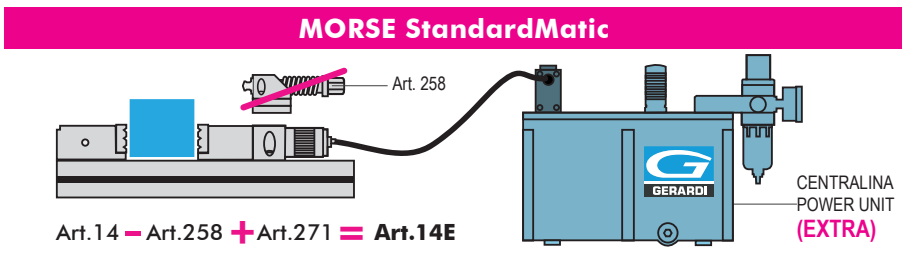
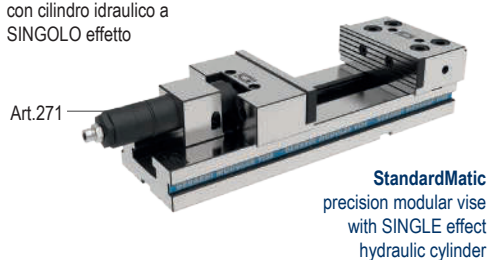

Dotazione standard:

- 1 arresto laterale Art. 370
- 1 coppia di tasselli di posizionamento per cava da 16 mm Art. 297
- 1 chiave a pipa Art. 375 ■ 1 chiave a "T" Art. 376

Extra per ogni foro calibrato (tolleranza F7) - MAN-010-STD

Extra per ogni chiavevitta (tolleranza H7) - MAN-020-STD

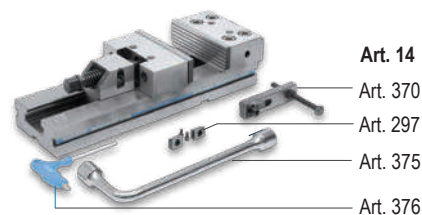

Standard equipment:

- 1 workstop Art. 370
- 1 pair of positioning key-nuts for 16 mm slot Art. 297
- 1 box wrench Art. 375 ■ 1 T-wrench Art. 376

Extra charge for each calibrated hole (F7 tolerance) - MAN-010-STD

Extra charge for each calibrated key nut (F7 tolerance) - MAN-020-STD

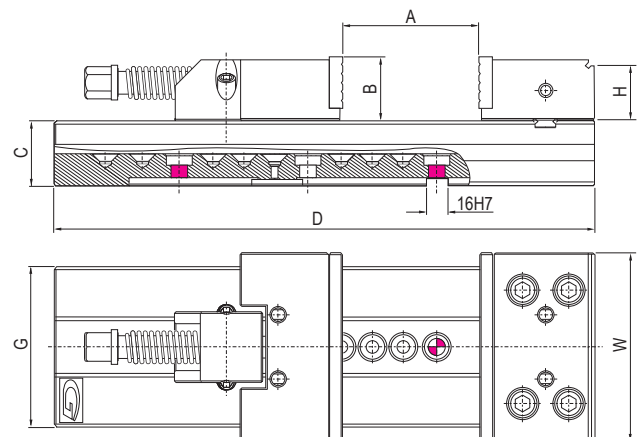
 Vedi gruppo 4 per gamma completa accessori
 See group 4 for complete range of accessories

	5 40 kN					6 40 kN						
A	200	300	400	500	600	200	300	400	500	600	700	800
W	200					300						
B	65					80						
C	70					78						
D	495	595	695	795	895	535	635	735	835	935	1035	1135
G	170					195						
kg	64	69	74	79	84	95	105	115	125	135	145	155
Cod.	1.14.52000	1.14.53000	1.14.54000	1.14.55000	1.14.56000	1.14.62000	1.14.63000	1.14.64000	1.14.65000	1.14.66000	1.14.67000	1.14.68000

UPGRADE YOUR VISE APPLICATIONS THROUGH MODULAR ACCESSORIES !

4.31.3500C	Art. 313		4.31.3600C
53			68
1.21.25000	Art. 212		1.21.26000
1.65.56200	Art. 246		1.65.66200
1.24.6G500	Art. 246G		1.24.6G600
Cod.	Vedi pag. 4.40 - 4.41 - See pag. 4.40 - 4.41		

StandardMatic VISES

Centralina Pneumoidraulica Art.393/394/395 (EXTRA)
 Pneumohydraulic Power Unit Art.393/394/395 (EXTRA)

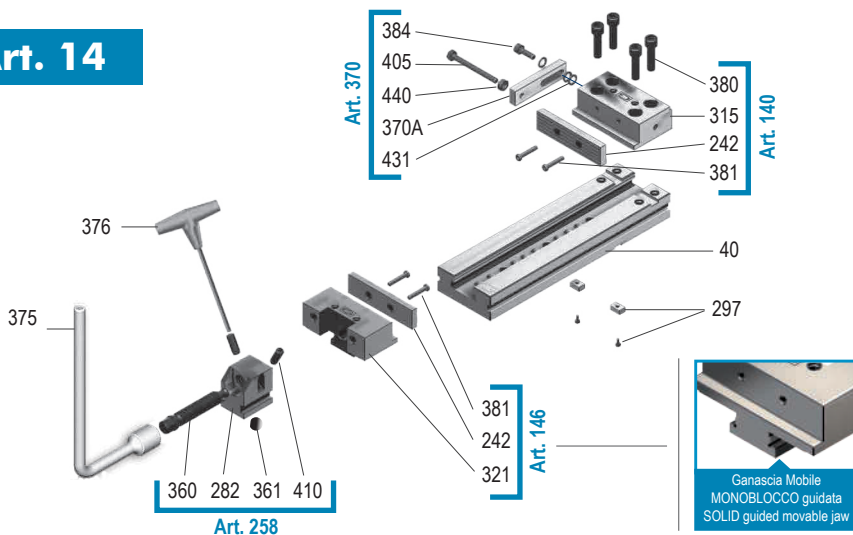

Art. 14

Art.	Pag.	Art.	Pag.
40	1.24	380	4.28
242	4.11	381	4.28
282	4.36	384	4.28
297	4.34	405	4.35
315	4.30	410	4.36
321	4.30	431	4.28
360	4.36	440	4.28
361	4.36	-	-
370A	4.35	-	-
375	4.35	-	-
376	4.35	-	-

Tipo (grandezza) morsa / Vise type (size)

	kN	1 16 kN	2 25 kN	3 30 kN		4 30 kN			
Apertura massima / Maximum spread	A	100	150	200	300	200	300	400	500
	W	75	95	125		145			
	B	30	40	50		60			
	C	35	40	50		58			
	D	270	345	420	520	455	555	655	755
	G	75	95	125		145			
	kg	6.2	11.9	24.2	27.8	35	39	46	51
	Cod.	1.15.10000	1.15.20000	1.15.32000	1.15.33000	1.15.42000	1.15.43000	1.15.44000	1.15.45000

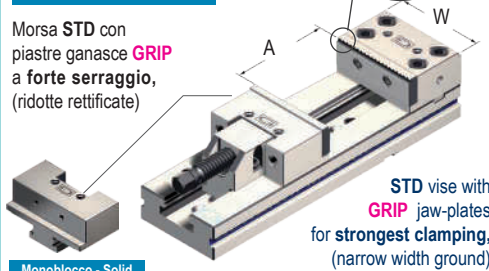
Art. 15

 Morsa STD con
 piastre ganasce **GRIP**
 a forte serraggio,
 (ridotte rettificate)

 STD vise with
GRIP jaw-plates
 for strongest clamping,
 (narrow width ground)

Monoblocco - Solid

AMPLIA LE TUE APPLICAZIONI TRAMITE GLI ACCESSORI MODULARI !
Art. 313R

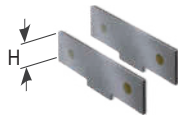
 Parallele magnetiche
 Magnetic parallel plates

 Vedi pagina 4.27 per altezze disponibili
 See page 4.27 for available height

Cod.	4.31.3R10C	4.31.3R20C	4.31.3R30C	4.31.3R40C
H	23	33	43	53

Art. 247

 Piastra piana ridotta in acciaio lavorabile
 Machinable steel narrow width straight jaw plate

Cod.	1.65.17200	1.65.27200	1.65.37200	1.65.47200

Art. 218

 Ganasca mobile prismatica
 Prismatic movable jaw

Cod.	2.21.81000	2.21.82000	2.21.83000	2.21.84000

Art. 247G

 Piastra ganasca ridotta con inserti GRIP
 completa di parallela magnetica
 Narrow width jaw plate with GRIP inserts with magnetic parallel



Cod.	1.24.7G100	1.24.7G200	1.24.7G300	1.24.7G400

Art. 15E
**NEW
2024**

 Morsa modulare **StandardMatic**
 con cilindro idraulico a
 SINGOLO effetto

StandardMatic
 precision modular vise
 with SINGLE effect
 hydraulic cylinder

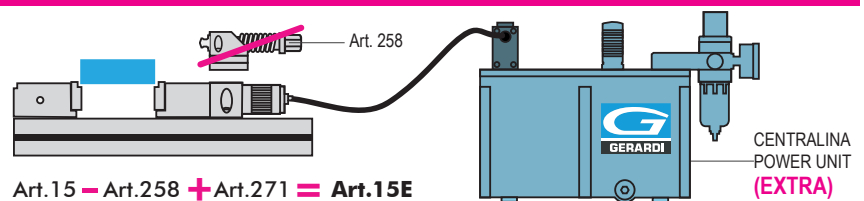
Cod.	Vedi pag. 4.40 - 4.41 - See pag. 4.40 - 4.41			

MORSE StandardMatic

Dotazione standard:

- 1 arresto laterale Art. 370
- 1 coppia di tasselli di posizionamento per cava da 16 mm Art. 297
- 1 chiave a pipa Art. 375 ■ 1 chiave a "T" Art. 376

Extra per ogni foro calibrato (tolleranza F7) - MAN-010-STD

Extra per ogni chiavevitta (tolleranza H7) - MAN-020-STD

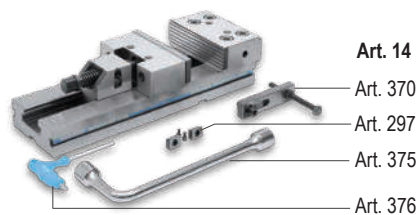

Standard equipment:

- 1 workstop Art. 370
- 1 pair of positioning key-nuts for 16 mm slot Art. 297
- 1 box wrench Art. 375 ■ 1 T-wrench Art. 376

Extra charge for each calibrated hole (F7 tolerance) - MAN-010-STD

Extra charge for each calibrated key nut (F7 tolerance) - MAN-020-STD

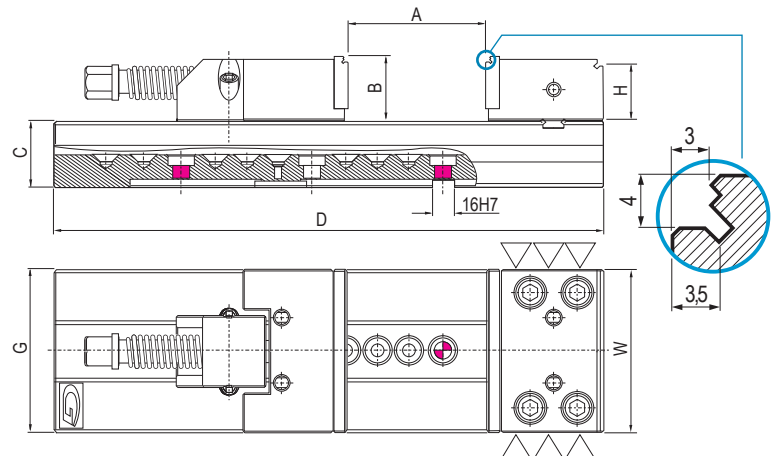
 Vedi gruppo 4 per gamma completa accessori
 See group 4 for complete range of accessories

	5 40 kN					6 40 kN						
A	200	300	400	500	600	200	300	400	500	600	700	800
W			170						195			
B			65						80			
C			70						78			
D	495	595	695	795	895	535	635	735	835	935	1035	1135
G			170						195			
kg	62	67	72	77	82	88	98	108	118	128	138	148
Cod.	1.15.52000	1.15.53000	1.15.54000	1.15.55000	1.15.56000	1.15.62000	1.15.63000	1.15.64000	1.15.65000	1.15.66000	1.15.67000	1.15.68000

UPGRADE YOUR VISE APPLICATIONS THROUGH MODULAR ACCESSORIES !

4.31.3R50C

4.31.3R60C

Art. 313R

53

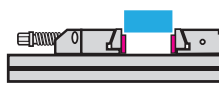

68

1.65.57200

1.65.67200

Art. 247

2.21.85000

2.21.86000

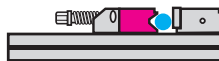
Art. 218

1.24.7G500

1.24.7G600

Art. 247G

Cod.

Vedi pag. 4.40 - 4.41 - See pag. 4.40 - 4.41

StandardMatic VISES

Centralina Pneumoidraulica Art.393/394/395 (EXTRA)
 Pneumohydraulic Power Unit Art.393/394/395 (EXTRA)

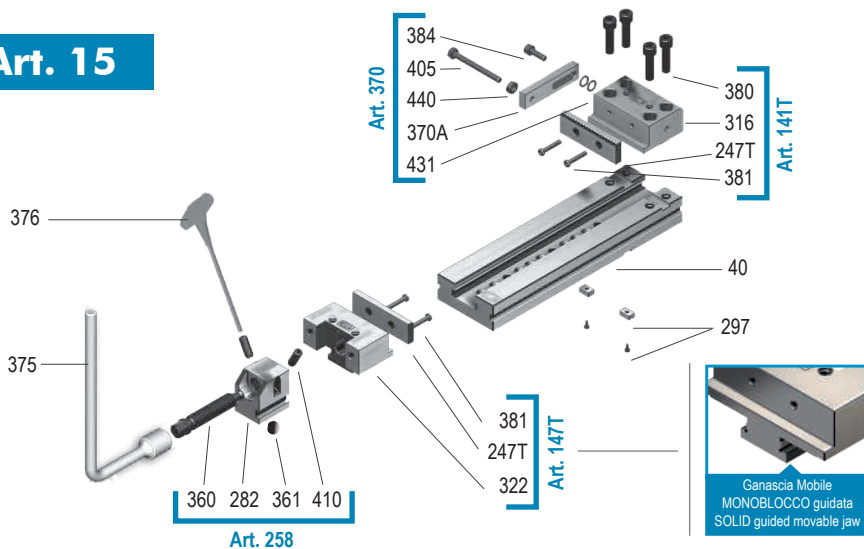
Art. 15

Art.	Pag.
40	1.24
247T	4.11
282	4.36
297	4.34
316	4.30
322	4.30
360	4.36
361	4.36
370A	4.35
375	4.35
376	4.35

Art.	Pag.
380	4.28
381	4.28
384	4.28
405	4.35
410	4.36
431	4.28
440	4.28
-	-
-	-
-	-
-	-

 Ganascia Mobile
 MONOBLOCCO guidata
 SOLID guided movable jaw

Morse e Cubi / Vises & Vise Towers

StandardFLEX

 Precisione / Accuracy
 $\pm 0,02\text{mm}$

 Durezza / Hardened
HRC 58 \pm 2

La morsa più evoluta!
 The most recent vise!

CARATTERISTICHE & VANTAGGI

- ✓ USURA INESISTENTE
- ✓ RAPIDITA' DEI SERRAGGI
- ✓ MODULARITA' & VERSATILITA'
- ✓ PRECISIONI $\pm 0,02\text{ mm}$
- ✓ RIGIDITA' & SICUREZZA
- ✓ DESIGN COMPATTO E MANEGGEVOLEZZA

Si rimanda a quanto esposto a pag. 1.4 e 1.5

TECHNICAL FEATURES & ADVANTAGES

- ✓ NO WEAR
- ✓ QUICK CLAMPING
- ✓ MODULARITY & VERSATILITY
- ✓ HIGHEST ACCURACIES $\pm 0,02\text{ mm}$
- ✓ RIGIDITY & SAFETY
- ✓ SPACE SAVING DESIGN & HANDY

See pag. 1.4 and 1.5 (STANDARD series vises)

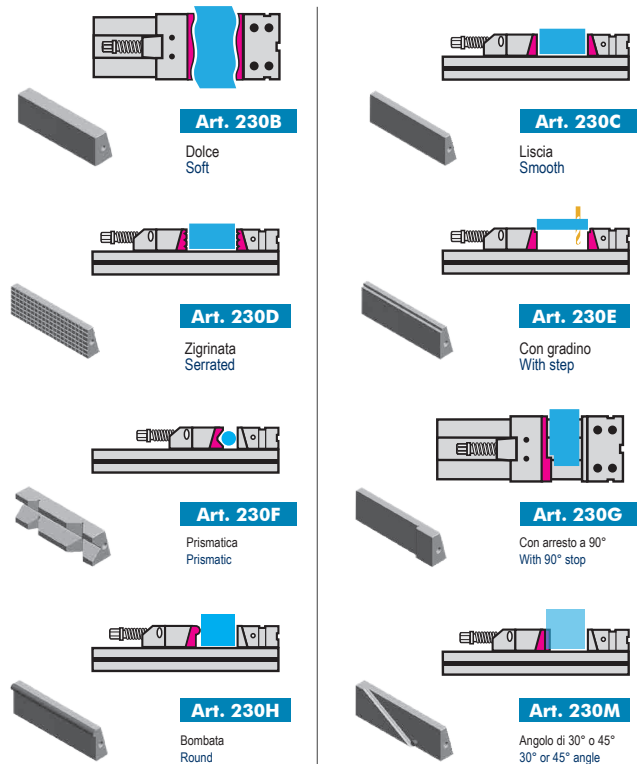

PIASTRE GANASCE DISCENDENTI INTERCAMBIABILI MANUALMENTE
 PULL DOWN JAW PLATES INTERCHANGEABLE BY HAND

Portapiastre The Rack

Completo di piastre ganasce a cambio rapido a gradino Art.230E
 Complete of quick change step jaw plates Art.230E

Vedi Pag. 4.22 - See Page.4.22

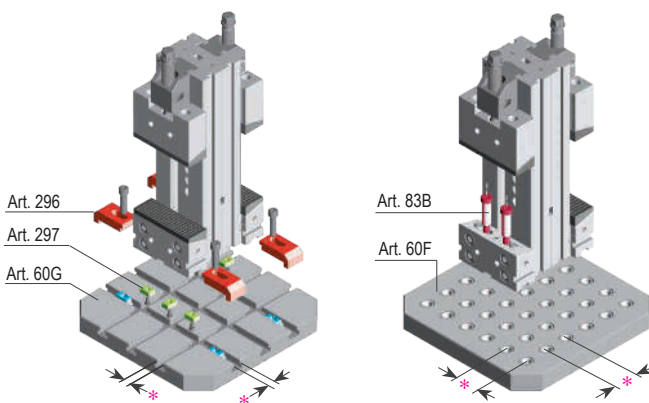

*** Cava / T slot = 16 mm**
 Ancoraggio e posizionamento con staffe e chivette
 Positioning and clamping through vise clamps

*** Passo / Pitch = 50 mm**
 Ancoraggio e posizionamento su reticolo
 Grid clamping and positioning

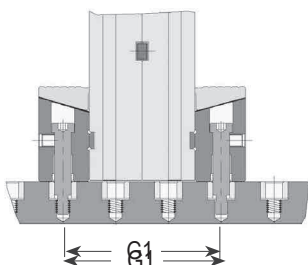

Tipo morsa Vise type	3	4	4	5
G1 mm	150	200	250	

Coda di Rondine Dove Tail

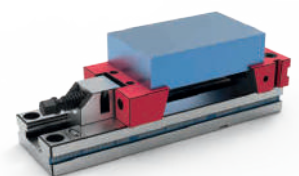

Rimuovendo le piastre ganasce è possibile sfruttare l'inclinazione a 15° del corpo per serrare il particolare, prelavando la faccia inferiore del particolare ottenendo così un sistema ad incastro irreversibile.

By taking off the jaw plates, it is possible to exploit the body inclination of 15° to clamp the workpiece and pre-machine the lower surface thus obtaining an irreversible dovetail system.

Le morse GERARDI della serie Standardflex sono un'evoluzione della morsa Standard. La loro caratteristica principale è la sostituzione rapida delle piastre ganasce che avviene manualmente e senza l'ausilio di alcun utensile, questo è possibile grazie al sistema Perno-molla, che consente un diverso utilizzo della morsa in tempi ridottissimi.

Grazie al sistema a Pettine di rigatura prismatica delle piastre ganasce, risulta migliorato anche l'effetto discendente che durante la fase di serraggio, trascina il pezzo contro lo slittone garantendo anche una notevolissima precisione di riposizionamento.

The GERARDI vises of the StandardFLEX series are an evolution of the Standard vise series. Their main characteristic is the quickest jaw plate hand substitution without any tool. This is possible thanks to the new design with pin with spring which increases the standard vise versatility while the prismatic grooves allow a perfect repositioning accuracy (within microns!!!).

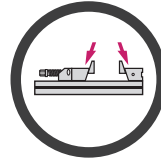

SCAN IT TO WATCH THE



VIDEO PRESENTATION



Dotata del geniale sistema a pettine per sostituire rapidamente la piastra ganasce discendente

Innovative Comb system for quick pull-down jaw plate change

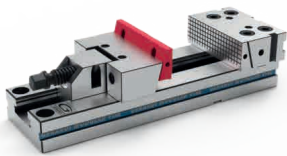

Riconfigurazione Rapidissima Quickest Vise Resetting

Grazie alla piastra ganasce intercambiabile manualmente tramite sistema a pettine

Thanks to the quick interchangeable jaw plate through ground comb system

Altissima Ripetibilità di Posizionamento Highest Repositioning Accuracy $\pm 0,005\text{mm}$

Veloce e preciso grazie alla forma rettificata del sistema a pettine
Quick and accurate jaw plate thanks the grid shape of the comb system

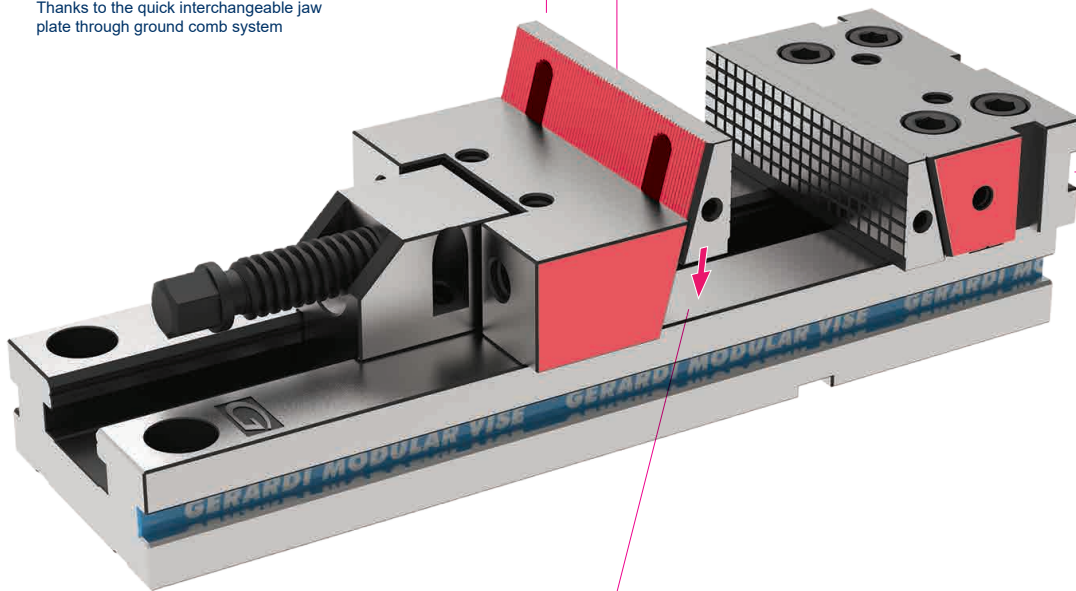

Effetto discendente Pull Down Action

Effetto discendente amplificato e migliorato e migliore protezione dai trucioli grazie al sistema a pettine.

Increased and better pull down action and better protection from chips thanks to the comb system

Montaggio Verticale Vertical Mounting

Montaggio in verticale di due morse StandardFlex contrapposte su piani a reticolo $\varnothing 16\text{mm}$

Example of vertical mounting of 2 StandardFlex vises back to back on grid base $\varnothing 16 - 50\text{mm Pitch}$

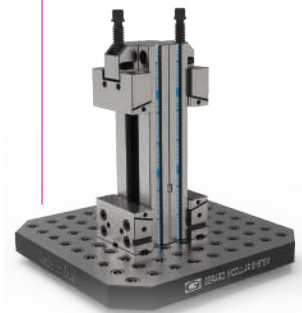

Tipo (grandezza) morsa / Vise type (size)

	kN	1 16 kN	2 25 kN	3 30 kN		4 30 kN			
Apertura massima / Maximum spread	A	100	150	200	300	200	300	400	500
	W	96	121	146		171			
	B	28	38	48		58			
	C	35	40	50		58			
	D	270	345	420	520	455	555	655	755
	G	75	95	125		145			
	kg	6.8	12.9	25.5	29	37	42	47	52
	Cod.	1.1A.10000	1.1A.20000	1.1A.32000	1.1A.33000	1.1A.42000	1.1A.43000	1.1A.44000	1.1A.45000

Art. 1A

Morsa **StandardFLEX** *
 con piastre ganasce
 a cambio rapido manuale
 (Sistema a pettine)

* Serraggi disassati
 lateralmente non
 possibili.

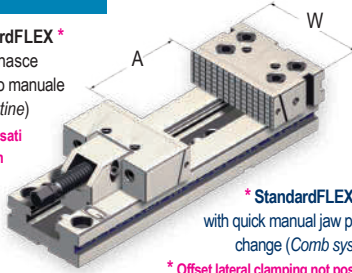

* **StandardFLEX** vise
 with quick manual jaw plates
 change (Comb system)

* Offset lateral clamping not possible

AMPLIA LE TUE APPLICAZIONI TRAMITE GLI ACCESSORI MODULARI !
Art. 230E

Piastra ganasce intercambiabile
 Interchangeable jaw plate

Vedi pagina 4.21 per altezze disponibili
 See page 4.21 for available height

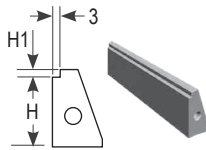

	Cod.	4.23.0E101	4.23.0E201	4.23.0E301	4.23.0E401
H		23	33	43	53
H1		5	5	5	5

Art. 212

Ganasce mobile intermedia
 (da usare con Art. 230E)

Intermediate movable jaw (to be used with Art. 230E)

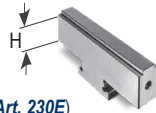

	Cod.	1.21.21000	1.21.22000	1.21.23000	1.21.24000

Art. 230B

Piastra ganasce intercambiabile dolce
 Soft interchangeable jaw plate

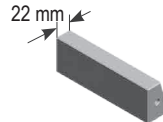

	Cod.	4.23.0B101	4.23.0B201	4.23.0B301	4.23.0B401

Art. 230F

Piastra ganasce intercambiabile prismatica
 Prismatic interchangeable jaw plate



	Cod.	4.23.0F101	4.23.0F201	4.23.0F301	4.23.0F401

Art. 1AE

NEW
2024

Morsa modulare **StandardMatic**
 con cilindro idraulico a
 SINGOLO effetto

Art.271

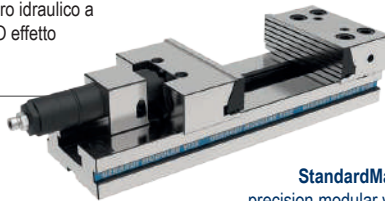

StandardMatic
 precision modular vise
 with SINGLE effect
 hydraulic cylinder

	Cod.	Vedi pag. 4.40 - 4.41 - See pag. 4.40 - 4.41

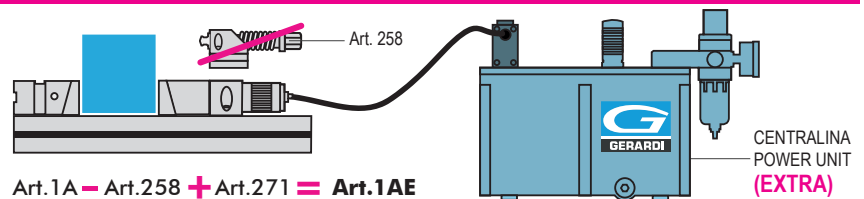
MORSE StandardMatic

Dotazione standard:

- 1 arresto laterale Art. 370
- 1 coppia di tasselli di posizionamento per cava da 16 mm Art. 297
- 2 tappi Art. 291 ■ 1 chiave a pipa Art. 375 ■ 1 chiave a "T" Art. 376

Fori rettificati e calibrati con tolleranza F7 già inclusi nel prezzo

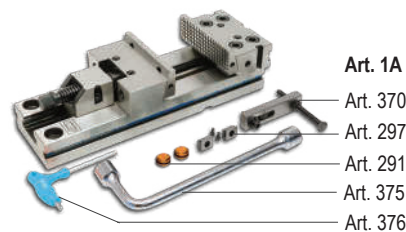

Standard equipment:

- 1 workstop Art. 370
- 1 pair of positioning key-nuts for 16 mm slot Art. 297
- 2 inserts Art. 291 ■ 1 box wrench Art. 375 ■ 1 T-wrench Art. 376

Ground calibrated holes F7 tolerance already included in the price

Vedi gruppo 4 per gamma completa accessori
 See group 4 for complete range of accessories

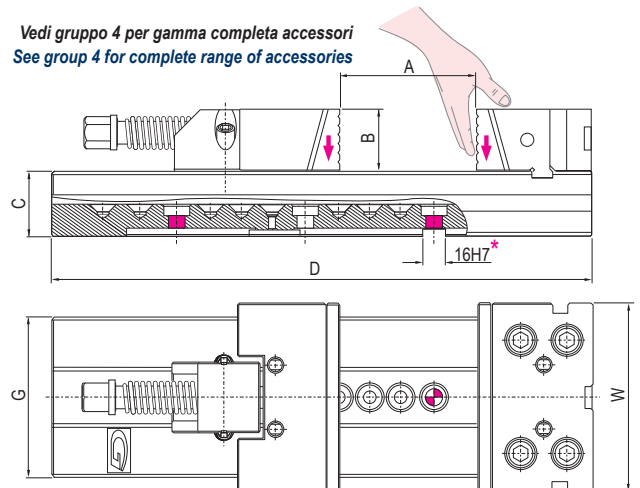

* Versione normale: Cava da 16H7 e fori calibrati Ø8F7 (t.1) - Ø16F7 (t.2-3-4-5-6)
 * Normal version: 16H7 slot and calibrated holes Ø8F7 (t.1) - Ø16F7 (t.2-3-4-5-6)

	5 40 kN					6 40 kN						
A	200	300	400	500	600	200	300	400	500	600	700	800
W	196					296						
B	63					78						
C	70					78						
D	495	595	695	795	895	535	635	735	835	935	1035	1135
G	170					195						
kg	64	69	74	79	84	95	105	115	125	135	145	155
Cod.	1.1A.52000	1.1A.53000	1.1A.54000	1.1A.55000	1.1A.56000	1.1A.62000	1.1A.63000	1.1A.64000	1.1A.65000	1.1A.66000	1.1A.67000	1.1A.68000

UPGRADE YOUR VISE APPLICATIONS THROUGH MODULAR ACCESSORIES !

4.23.0E501

Art. 230E

H	53
H1	10

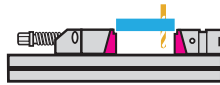

4.23.0E601

68
10

1.21.25000

Art. 212



1.21.26000

4.23.0B501

Art. 230B

4.23.0B601

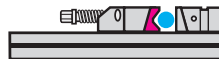
4.23.0F501

Art. 230F

4.23.0F601

Cod.

Vedi pag. 4.40 - 4.41 - See pag. 4.40 - 4.41

StandardMatic VISES

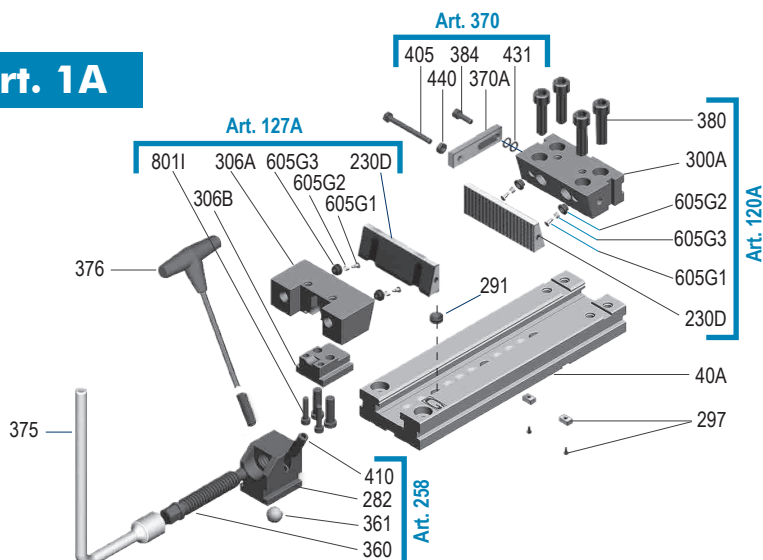
Centralina Pneumoidraulica Art.393/394/395 (EXTRA)
Pneumohydraulic Power Unit Art.393/394/395 (EXTRA)
Art. 1A

Art.	Pag.
40A	1.24
230D	4.21
282	4.36
291	4.35
297	4.34
300A	4.30
306A	4.30
306B	4.30
360	4.36
361	4.36
370A	4.35
375	4.35

Art.	Pag.
376	4.35
380	4.28
384	4.28
405	4.35
410	4.36
431	4.28
440	4.28
605G1	4.22
605G2	4.22
605G3	4.22
801I	5.61
-	-

Tipo (grandezza) morsa / Vise type (size)	kN	1*		2		3		4	
		16 kN	25 kN	30 kN		30 kN			
Apertura massima / Maximum spread	A	100	150	200	300	200	300	400	500
Art. 1AZ	W	96	121	146		171			
	B	28	38	48		58			
	C	35	40	50		58			
	D	270	345	420	520	455	555	655	755
	G	75	95	125		145			
	kg	7.3	13.2	26.2	29.7	37.9	43	48.1	53.2
	Cod.	1.1A.Z1000	1.1A.Z2000	1.1A.Z3200	1.1A.Z3300	1.1A.Z4200	1.1A.Z4300	1.1A.Z4400	1.1A.Z4500

Morsa **StandardFLEX** *
 per **Zero Point** con
 piastre ganasce a
 cambio rapido manuale

* Serraggi disassati
 lateralmente non
 possibili.

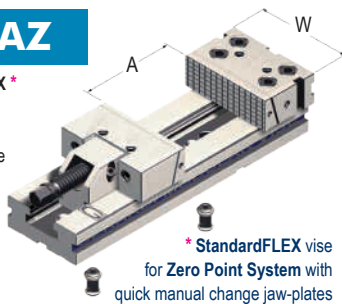

* **StandardFLEX** vise
 for **Zero Point** System with
 quick manual change jaw-plates
 * Offset lateral clamping not possible

AMPLIA LE TUE APPLICAZIONI TRAMITE GLI ACCESSORI MODULARI !

Art. 230E	Cod.		4.23.0E101		4.23.0E201		4.23.0E301		4.23.0E401	
	Piastra ganasce intercambiabile Interchangeable jaw plate	H	23	33	43					53
Vedi pagina 4.21 per altezze disponibili See page 4.21 for available height	H1	5	5	5					5	

Art. 212	Cod.		1.21.21000		1.21.22000		1.21.23000		1.21.24000	
	Ganasce mobile intermedia (da usare con Art. 230E) Intermediate movable jaw (to be used with Art. 230E)	[Diagram showing dimensions H and 3]								

Art. 230B	Cod.		4.23.0B101		4.23.0B201		4.23.0B301		4.23.0B401	
	Piastra ganasce intercambiabile dolce Soft interchangeable jaw plate	[Diagram showing dimension 22 mm]								

Art. 230F	Cod.		4.23.0F101		4.23.0F201		4.23.0F301		4.23.0F401	
	Piastra ganasce intercambiabile prismatica Prismatic interchangeable jaw plate	[Diagram showing prismatic shape]								

Art. 1AZE	Cod.		Vedi pag. 4.40 - 4.41 - See pag. 4.40 - 4.41							
	Morsa modulare StandardMatic con cilindro idraulico a SINGOLO effetto	[Diagram showing modular vise]								

MORSE StandardMatic

Art.271 + Art.258 = Art.1AZE

StandardMatic precision modular vise with SINGLE effect hydraulic cylinder

Art. 1AZ - Art. 258 + Art. 271 = Art. 1AZE

CENTRALINA POWER UNIT (EXTRA)

- Dotazione standard:
- 1 arresto laterale Art. 370
 - 2 tiranti Art. 10A
 - 2 tappi Art. 291
 - 1 chiave a pipa Art. 375
 - 1 chiave a "T" Art. 376

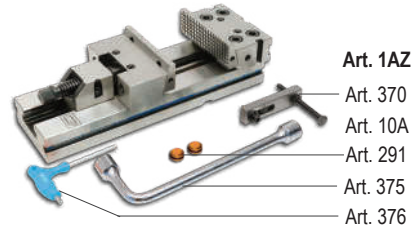

Standard equipment:

- 1 workstop Art. 370
- 2 pullstuds Art. 10A
- 2 inserts Art. 291
- 1 box wrench Art. 375
- 1 T-wrench Art. 376

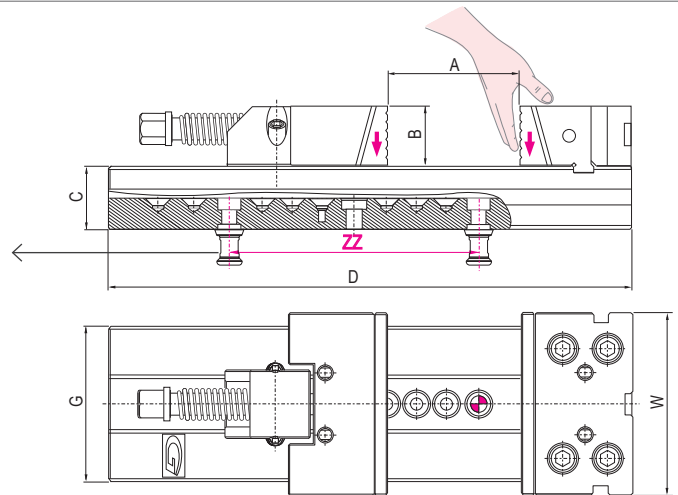

* Per morsa Tipo 1 sedi per tiranti 10A (tipo1) con interasse dei fori 150mm - Quote interassi tiranti ZZ a pag.1.24

For Vise T.1 - 10A pull studs positioning holes (T.1) with 150mm pitch - See on pag. 1.24 for pull studs pitches ZZ

Vedi gruppo 4 per gamma completa accessori
 See group 4 for complete range of accessories

	5 40 kN					6 40 kN						
A	200	300	400	500	600	200	300	400	500	600	700	800
W	196					296						
B	63					78						
C	70					78						
D	495	595	695	795	895	535	635	735	835	935	1035	1135
G	200					300						
kg	65.3	70.3	75.3	80.3	85.3	97	107	117	127	137	147	157
Cod.	1.1A.Z5200	1.1A.Z5300	1.1A.Z5400	1.1A.Z5500	1.1A.Z5600	1.1A.Z6200	1.1A.Z6300	1.1A.Z6400	1.1A.Z6500	1.1A.Z6600	1.1A.Z6700	1.1A.Z6800

UPGRADE YOUR VISE APPLICATIONS THROUGH MODULAR ACCESSORIES !

4.23.0E501

Art. 230E

H	53
H1	10

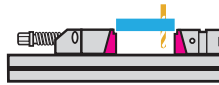

4.23.0E601

68
10

1.21.25000

Art. 212



1.21.26000

4.23.0B501

Art. 230B

4.23.0B601

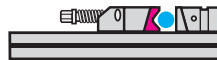
4.23.0F501

Art. 230F

4.23.0F601

Cod.

Vedi pag. 4.40 - 4.41 - See pag. 4.40 - 4.41

StandardMatic VISES

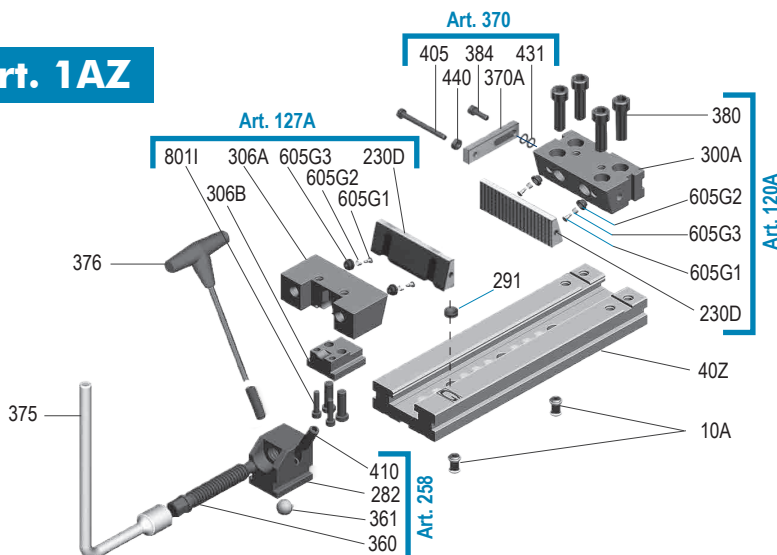
Centralina Pneumoidraulica Art.393/394/395 (EXTRA)
Pneumohydraulic Power Unit Art.393/394/395 (EXTRA)
Art. 1AZ

Art.	Pag.
10A	9.31
40Z	1.24
230D	4.21
282	4.36
291	4.35
300A	4.30
306A	4.30
306B	4.30
360	4.36
361	4.36
370A	4.35
375	4.35

Art.	Pag.
376	4.35
380	4.28
384	4.28
405	4.35
410	4.36
431	4.28
440	4.28
605G1	4.22
605G2	4.22
605G3	4.22
801I	5.61
-	-

Tipo (grandezza) / Type (size)
Art. 40

 Slittone base
 serie **STD** senza
 alcuna dotazione

 Vise base
STD series
 supplied without any accessory

	1	2	3	4				
C	35	40	50	58				
D	270	345	420	520	455	555	655	755
G	75	95	125	145				
K	-	-	100	100				
N	2	3	3	4	3	4	5	6
U	111	111	122,5		129			
Z	100	100	100		100			
kg	3,8	7,3	15,1	18,7	20,6	25,2	29,7	34,5
Cod.	1.80.10270	1.80.20345	1.80.30420	1.80.30520	1.80.40455	1.80.40555	1.80.40655	1.80.40755

 Versione normale: Cave da 16mm (H7) - Versione opzionale: Fori rettificati e calibrati con tolleranza F7 - *Extra per ogni foro calibrato (tolleranza F7) - MAN-010-STD:*
Art. 40A

 Slittone base serie
StandardFLEX senza
 alcuna dotazione

 Vise base
StandardFLEX series
 supplied without any accessory

kg	3,8	7,3	15,1	18,7	20,6	25,2	29,7	34,5
Cod.	1.40.A1000	1.40.A2000	1.40.A3200	1.40.A3300	1.40.A4200	1.40.A4300	1.40.A4400	1.40.A4500

Art. 40Z

 Slittone base
 serie **Zero Point**
 senza alcuna
 dotazione

 Vise base
Zero Point series
 supplied without any accessory

ZZ	150*	200	200	200	200	200	300	300
kg	4	8	15,5	19	21	25,5	30	35
Cod.	1.40.Z1000	1.40.Z2000	1.40.Z3200	1.40.Z3300	1.40.Z4200	1.40.Z4300	1.40.Z4400	1.40.Z4500

* Per morsa Tipo 1 sedi per tiranti 10A (tipo1) con interasse dei fori 150mm.

PIASTRE D'INTERFACCIA ZERO POINT PER MORSE STD
Art. 62
STD

 Piastra di interfaccia
 Zero Point per
 morse STD

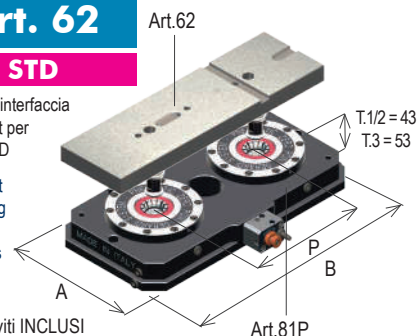
 Zero Point
 connecting
 plate for
 STD vises

 Tiranti e viti **INCLUSI**
 Pull Studs and screws **INCLUDED**

C1	28	28	33		33			
UU	86	86	97,5	97,5	104	104	104	104
ZZ	200	200	200	250	200	250	200x2	200x2
kg	4,5	7,2	13,5	16,7	17	20,8	24,4	28,2
Cod.	1.62.11000	1.62.21500	1.62.32000	1.62.33000	1.62.42000	1.62.43000	1.62.44000	1.62.45000

A	200	200	200	200	200	200	200	200
B	400	400	400	500	400	500	600	600

Art. 665	Tipo / Type 1	Tipo / Type T.2						
P	200	200	200	250	200	250	200x2	200x2
kg	31	29	29	35	29	35	42	42

Cod. 9.81.P12040S2 9.81.P2040S2 9.81.P2040S2 9.81.P2050S2 9.81.P2040S2 9.81.P2050S2 9.81.P2060S3 9.81.P2060S3

Art. 81P

 Piastra Zero Point in acciaio con montaggio incassato
 Zero Point steel plate built-in mounting

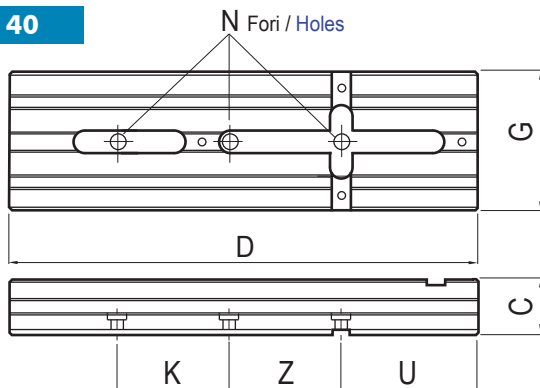
Art. 40

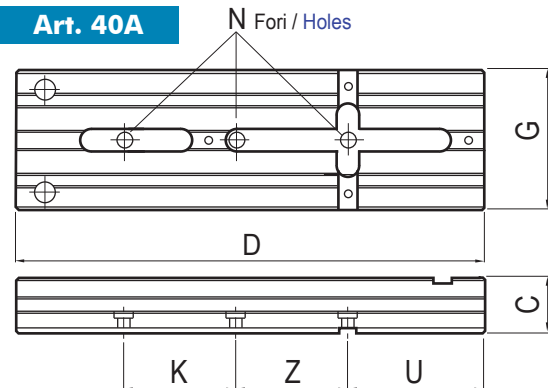
 Versione normale: Cave da 16 mm (H7)
 Normal version: 16 mm slots (H7)

Art. 40A

 Versione normale: Cave da 16H7 e fori calibrati Ø8F7 (t.1) - Ø16F7 (t.2-3-4-5-6)
 Normal version: 16H7 slot and calibrated holes Ø8F7 (t.1) - Ø16F7 (t.2-3-4-5-6)

	5					6						
C	70					78						
D	495	595	695	795	895	535	635	735	835	935	1035	1135
G	170					195						
K	100					100						
N	2	3	4	5	6	4	5	6	7	8	9	10
U	145					152						
Z	100					100						
kg	32,6	39,2	45,8	52,5	59	47	56	65	74	83	61	100
Cod.	1.80.50495	1.80.50595	1.80.50695	1.80.50795	1.80.50895	1.80.60535	1.80.60635	1.80.60735	1.80.60835	1.80.60935	1.80.60035	1.80.60135

Normal version: 16mm slots (H7) - Optional version: Ground calibrated holes F7 tolerance - **Extra for each calibrated hole (F7 Tolerance):**

kg	32,6	39,2	45,8	52,5	59	47	56	65	74	83	91	100
Cod.	1.40.A5200	1.40.A5300	1.40.A5400	1.40.A5500	1.40.A5600	1.40.A6200	1.40.A6300	1.40.A6400	1.40.A6500	1.40.A6600	1.40.A6700	1.40.A6800

ZZ	200	200	300	300	300	300	300	300	300	300	300x2	300x2
kg	33	40	46	53	59	47	56	65	74	83	91	100
Cod.	1.40.Z5200	1.40.Z5300	1.40.Z5400	1.40.Z5500	1.40.Z5600	1.40.Z6200	1.40.Z6300	1.40.Z6400	1.40.Z6500	1.40.Z6600	1.40.Z6700	1.40.Z6800

* For Vise T.1 - 10A pull stud positioning holes (T.1) with 150mm pitch

ZERO POINT CONNECTING PLATES FOR STD VISES

C1	38					38						
UU	120					127						
ZZ	250	200	200x2	300x2	300x2	250	200x2	200x2	300x2	300x2	400x2	400x2
kg	25	30	35	40	45	31	36,7	42,5	48,3	54	59,8	65,6
Cod.	1.62.52000	1.62.53000	1.62.54000	1.62.55000	1.62.56000	1.62.62000	1.62.63000	1.62.64000	1.62.65000	1.62.66000	1.62.67000	1.62.68000

A	200	200	200	200	200	250	250	250	250	250	250	250
B	500	400	600	800	800	500	600	600	800	800	1000	1000
Art. 665	Tipo / Type T.2					Tipo / Type 3						
P	250	200	200x2	300x2	300x2	250	200x2	200x2	300x2	300x2	400x2	400x2
kg	35	29	42	59	59	-	-	-	-	-	-	-
Cod.	9.81.P2050S2	9.81.P2040S2	9.81.P2060S3	9.81.P2080S3	9.81.P2080S3	9.81.P32550S2	9.81.P32560S3	9.81.P32560S3	9.81.P32580S3	9.81.P32580S3	9.81.P325100S3	9.81.P325100S3

Art. 40Z

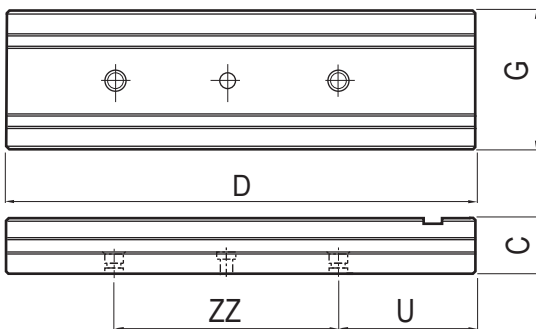

Versione normale: 2 o 3 fori filettati per tiranti Art. 10A - Tipo 2
 Normal version: 2-3 holes threaded for pull studs Art. 10A - Type 2

Art. 62

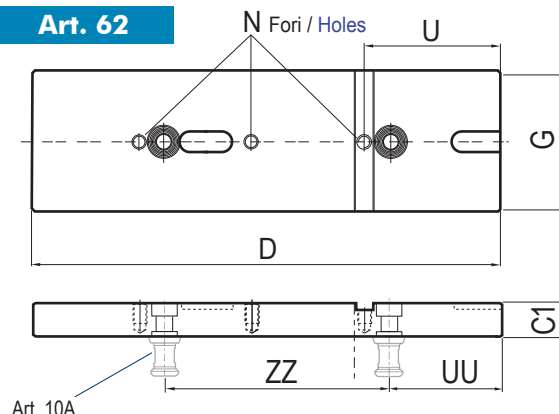

Tipo (grandezza) morsa / Vise type (size)		1	2	3	4					
Tolleranza / Tolerance										
-0,02	C	35	40	50	58					
-	D	270	345	420	520	455	555	655	755	
-0,02	F	10	12	13	15					
+0,02	F1	10	10	12	18					
-0,02	G	75	95	125	145					
+0,02	Y	21	28	41	51					
-	Y1	31	41	57	70					
-	M	M10	M12	M14	M16					
-	N	76	76	84,5	89					
-	N1	35	35	38	40					
-	O	32	32	36	36					
-	P	19	19	20	22					
-	Q	50	62	88	100					
-	T	9,5	9,5	11,5	11,5					
-	T1	15	15	20	20					
-	T2	5	5	7	7					
-	U	111	111	122,5	129					
-	U1	111	111	122,5	129	229				
-	K	-	-	100	100					
-	Z	100	100	100	100					

Art. 40

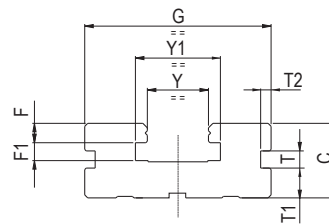
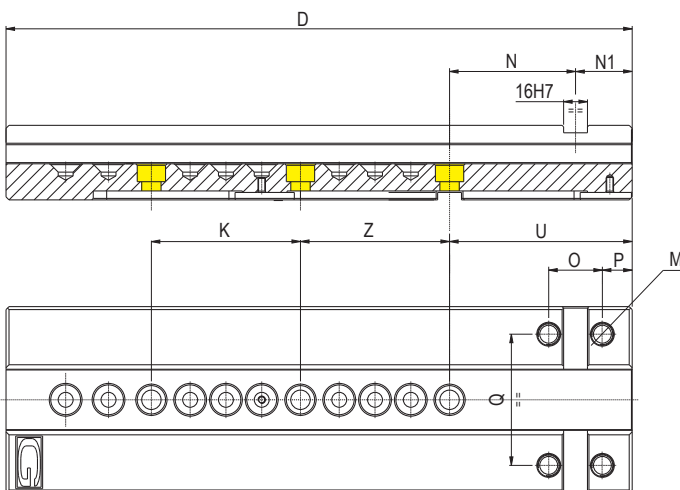
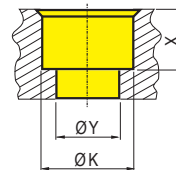
 Slittone base serie **STD** / Vise base **STD** series

Dettaglio foro per vite TCEI / TCEI screw hole details

Type	1	2	3	4	5	6
X	4,5	5,5	12,5	12,5	17	17
ØY	6,5	8,5	13	13	17	17
ØK	10,5	13,5	19	19	26	26

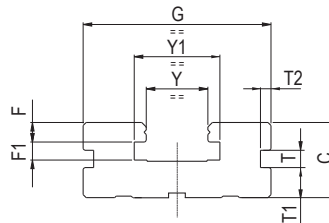
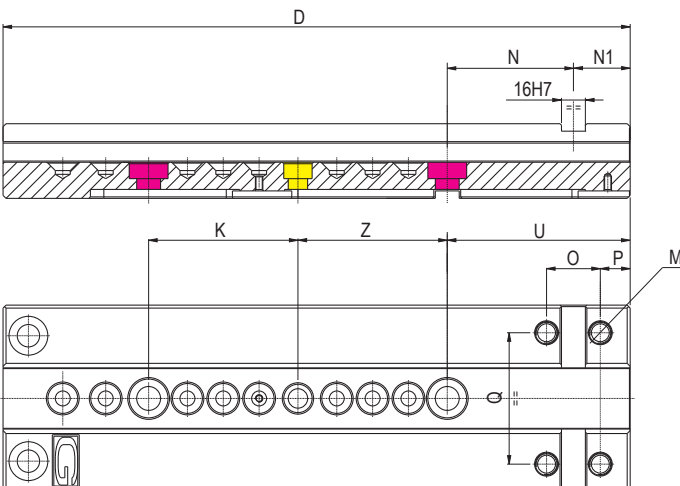
Art. 40A

 Slittone base serie **StandardFLEX** / Vise base **StandardFLEX** series

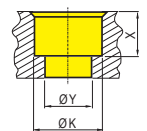
Dettaglio foro per vite TCEI
TCEI screw hole details
TIPO 3 - TYPE 3

Type	3
X	8
ØY	13
ØK	19

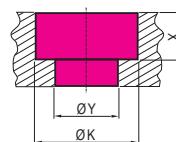

 Vedi tabella TCEI Art.40 per altre tipologie
 See the TCEI chart of Art.40 for all other types

Dettaglio foro per vite calibrata / Calibrated screw hole details

Type	1	2	3	4	5	6
X	4,5	5,5	8	11		
ØY	8F7	16F7	16	16F7		
ØK	13,5	21	21	25		

	5				6					
C	70				78					
D	535				635	735	835	935	1035	1135
F	20				20					
F1	18				18					
G	170				195					
Y	61				71					
Y1	80				91					
M	M20				M20					
N	100				107					
N1	45				45					
O	44				44					
P	23				23					
Q	120				133					
T	17,5				17,5					
T1	26				26					
T2	10				10					
U	145				152					
U1	145	245		152		252	152			
K	100				100					
Z	100				100					

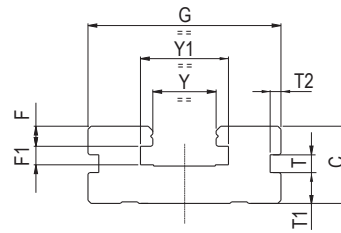
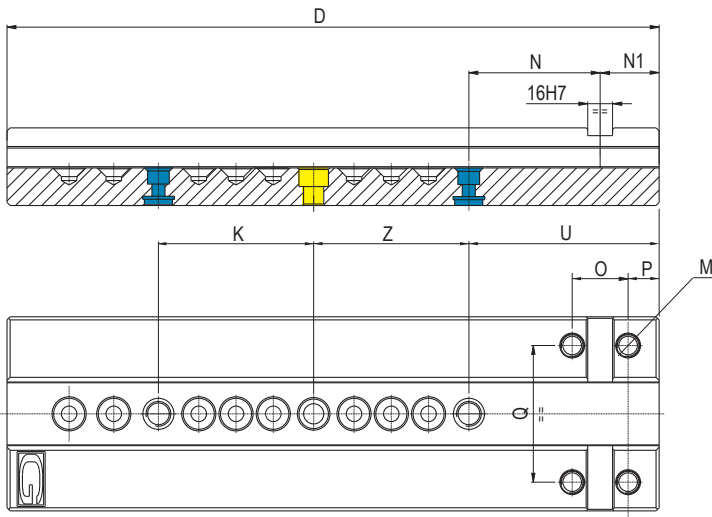
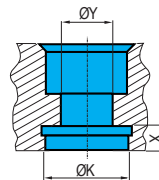
Art. 40Z

 Slittone base serie **ZERO POINT** / Vise base **ZERO POINT** series

Dettaglio foro per Zero Point / Zero Point hole details

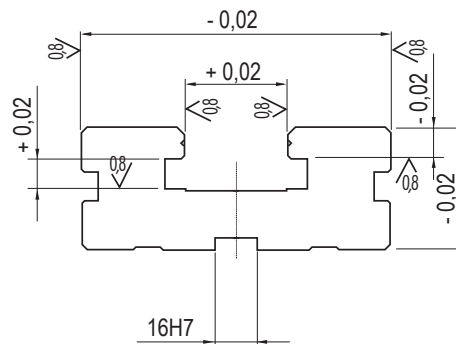
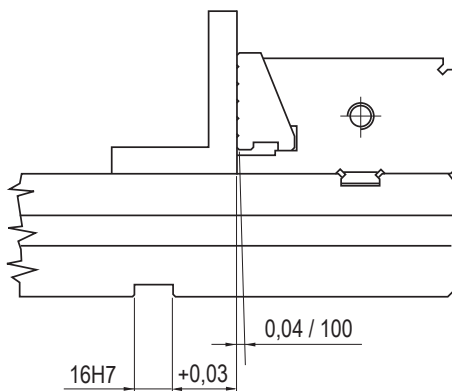
Type	1	2	3	4	5	6
X	6					
Ø Y	13					
Ø K	20					

 Tolleranze generiche per morse **XL** / **XL** vise generic tolerances

Tipo (grandezza) morsa / Vise type (size)

	1	
	16 kN	
kN		
A	80	130

Art. 700

Cubomorsa modulare standard in **monoblocco**
 Standard modular vise tower in **solid body**

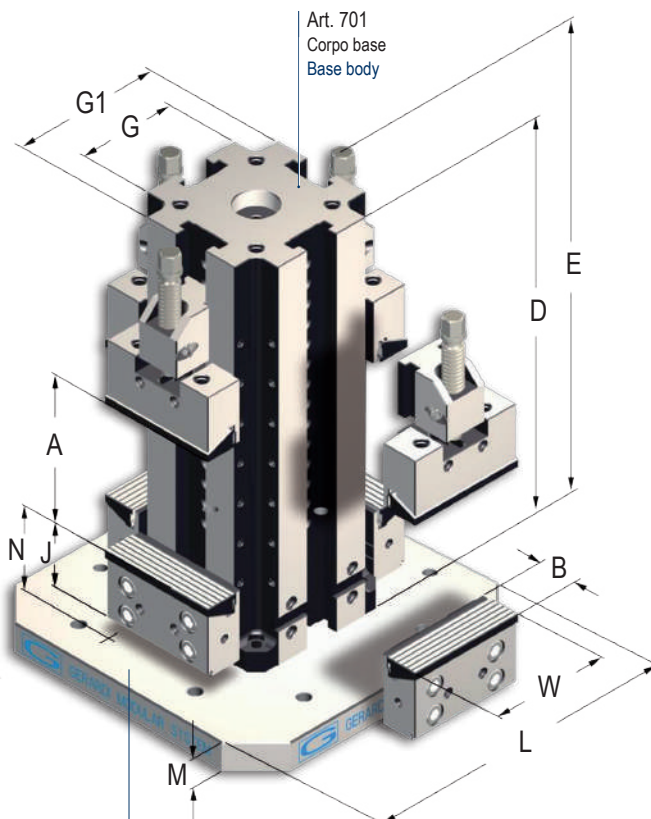
Dotazione standard:

- 4 arresti laterali Art. 370
- 2 coppie di tasselli di posizionamento per cava da 16 mm Art. 297
- 1 chiave a pipa Art. 375
- 1 chiave a "T" Art. 376

Standard equipment:

- 4 workstops Art. 370
- 2 pairs of positioning key-nuts for 16 mm slot Art. 297
- 1 box wrench Art. 375
- 1 "T"- wrench Art. 376

Art. 828A (extra)

W	100	
B	30	
D	250	300
E	300	350
G	75	
G1	120	
J	77,9	
L	300	
M	33	
N	85	
kg	37	42
Cod.	3.70.00801	3.70.01301

Tipo (grandezza) morsa / Vise type (size)

	1	
	16 kN	
kN		

Apertura massima / Maximum spread

A	100	
D	270 *	
E	320	
P	75 *	
kg	10	
Cod.	1.75.01000	

Art. 750

Morse standard montate verticalmente
 N° 4 morse STD Art. 1+ N° 1 Art. 450
 Standard vises vertically mounted
 N° 4 vises STD Art. 1+ N° 1 Art. 450

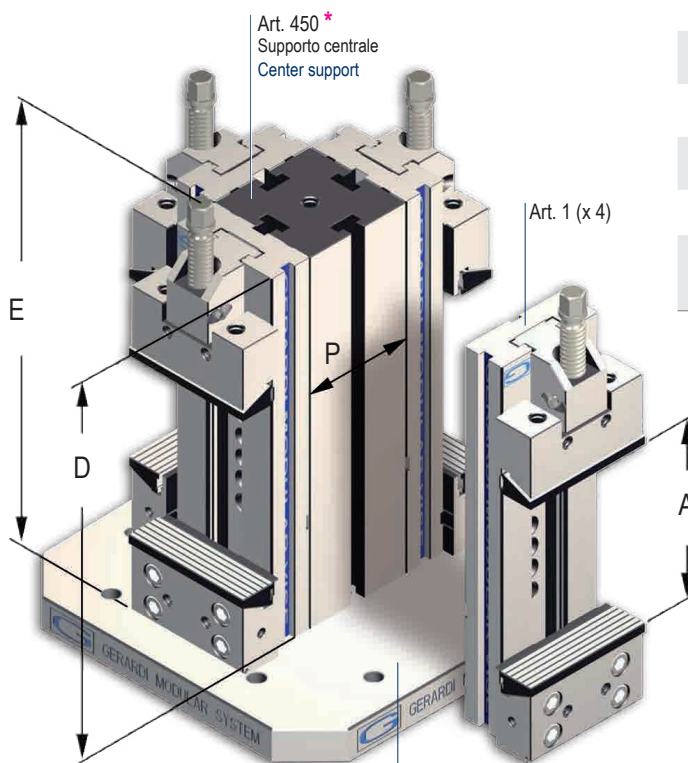
Dotazione standard:

- 4 arresti laterali Art. 370
- 2 coppie di tasselli di posizionamento per cava da 16 mm Art. 297
- 1 chiave a pipa Art. 375
- 1 chiave a "T" Art. 376

Standard equipment:

- 4 workstops Art. 370
- 2 pairs of positioning key-nuts for 16 mm slot Art. 297
- 1 box wrench Art. 375
- 1 "T"- wrench Art. 376

Art. 828A (extra)

	2 25 kN		3 30 kN			4 30 kN				5 40 kN	6 40 kN
A	155	205	170	270	370	145	245	345	445	-	-
W	125		150			175				200	300
B	40		50			60				-	-
D	350	400	400	500	600	400	500	600	700	-	-
E	430	480	470	570	670	475	575	675	775	-	-
G	95		125			145				170	195
G1	160		190			230				*	*
J	77,9		89,4			96,9				*	*
L	350		400			450				*	*
M	33		38			38				-	-
N	85		102			111				-	-
kg	83	96	137	160	183	197	230	263	296	-	-
Cod.	3.70.01552	3.70.02052	3.70.01803	3.70.02803	3.70.03803	3.70.01454	3.70.02454	3.70.03454	3.70.04454	-	-

* Altre dimensioni a richiesta / Other dimensions on request

	2 25 kN	3 30 kN		4 30 kN				5 40 kN			6 40 kN		
A	150	200	300	200	300	400	500	200	300	400	300	400	500
D	345 *	420	520	455	555	655	755	495	595	695	635	735	835
E	345	450	550	455				-			-		
P	95 *	125		145				170			195		
kg	19	46		68				98			145		
Cod.	1.75.02000	1.75.03200	1.75.03300	1.75.04200	1.75.04300	1.75.04400	1.75.04500	1.75.05200	1.75.05300	1.75.05400	1.75.06300	1.75.06400	1.75.06500

* Altre dimensioni a richiesta / Other dimensions on request



** Montaggio e allineamento ESCLUSI
 Mounting and alignment EXCLUDED



Tipo (grandezza) / Type (size)

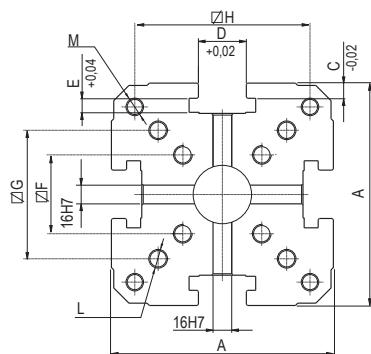

Art. 701

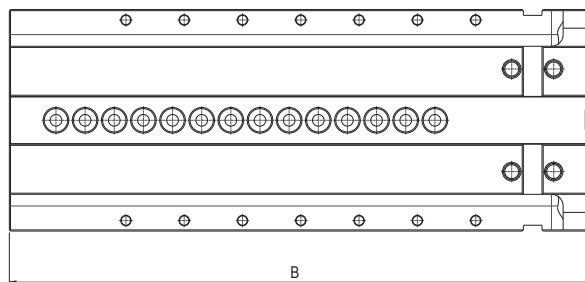

Senza alcuna dotazione
Without accessory equipment

Art. 701

Corpo slittone standard
Body for standard vise tower

Tipo (grandezza) / Type (size)

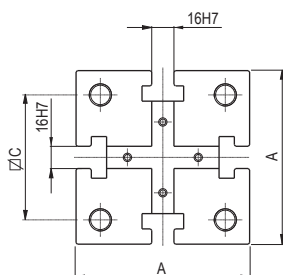

Art. 450



Senza alcuna dotazione
Without accessory equipment

Art. 450

Supporto centrale per montaggio morse modulari standard in verticale. Dolce.
Center support for vertical arrangement of standard modular vises. Soft.

Tipo (grandezza) / Type (size)

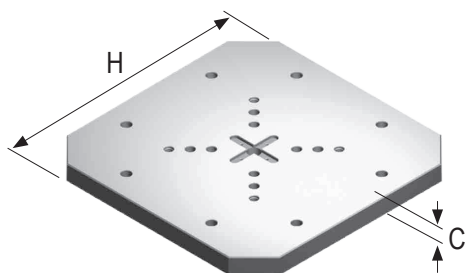

Art. 828A

STD

Piastra base per cubo-morsa personalizzata
(Bussola di centraggio Art. 852 compresa)
Head plate for vise-tower tailor made
(Centering bushing Art. 852 included)

	1		2		3			4				5	6
A	120		160		190			200				*	*
B	250	300	350	400	400	500	600	400	500	600	700	*	*
C	10		12		13			15				20	20
D	21		28		41			51				61	71
E	10		10		12			18				18	18
F	40		54		70			80				80	
G	70		84		110			134				134	
H	-		120		150			200				210	
L	M12		M16		M16			M20				M20	*
M	-		Ø 13		Ø 13			Ø 13				Ø 13	
kg	25	30	64	73	92	115	138	135	168	200	232	*	
Cod.	1.70.10801	1.70.11301	1.70.11552	1.70.12052	1.70.11803	1.70.12803	1.70.10803	1.70.11454	1.70.12454	1.70.13454	1.70.14454	*	

*A richiesta / On request

	1	2	3		4				5			6		
A	75	95	125		145				170			195		
B	270	345	420	520	455	555	655	755	495	595	695	635	735	835
C	50	60	90		110				110			*		
D	M12	M16	M16		M16				M20			*		
kg	10	19	46		68				98			145		
Cod.	1.45.01000	1.45.02000	1.45.03420	1.45.03520	1.45.04455	1.45.04555	1.45.04655	1.45.04755	1.45.05495	1.45.05595	1.45.05695	1.45.06635	1.45.06735	1.45.06835

*A richiesta / On request

	1	2	3	4	5	6	7
C	33	33	38	38	38	38	38
H	300	350	400	450	500	630	800
kg	22	30	44,5	56,5	71	113	182
Cod.	1.82.8A100	1.82.8A200	1.82.8A300	1.82.8A400	1.82.8A500	1.82.8A600	1.82.8A700

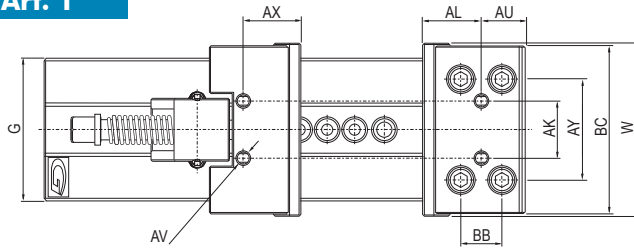
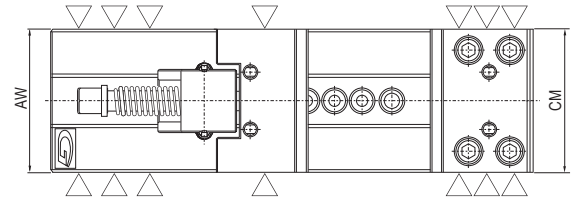
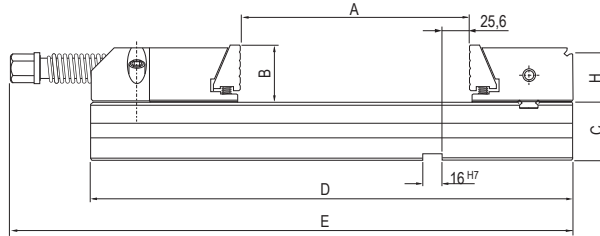
Art. 1

Art. 12

Art. 1+12

Tipo (grandezza) morsa / Vise type (size)

Tabella dimensionale / Table dimension

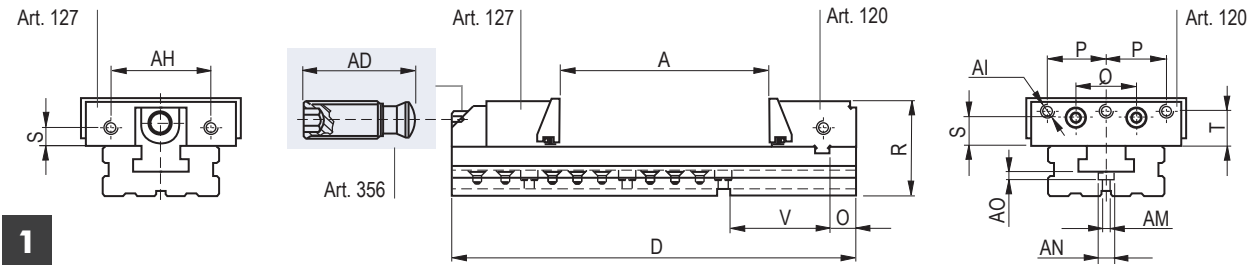
mm	1			2			3			4				5				6			
W	100	125	150	175			200				300										
A	100	150	200	300	200	300	400	500	200	300	400	500	600	200	300	400	500	600	700	800	
B	30	40	50	60				65				80									
C	35	40	50	58				70				78									
D	270	345	420	520	455	555	655	755	495	595	695	795	895	535	635	735	835	935	1035	1135	
E	320	425	500	600	530	630	730	830	580	680	780	880	980	630	730	830	930	1030	1130	1230	
F	225	285	370	470	385	485	585	685	410	510	610	710	810	440	540	640	740	840	940	1040	
G	75	95	125	145				170				195									
H	23	33	43	53				53				68									
I	55	70	110	160	110	160	210	260	105	165	205	265	305	115	165	215	265	315	365	415	
J	34	50	70	104	70	104	137	170	67	107	134	174	200	74	107	140	174	207	240	274	
K	124	174	226	326	226	326	426	526	236	336	436	536	636	236	336	436	536	636	736	836	

mm	1	2	3	4	5	6	Tolleranza Tolerance	mm	1	2	3	4	5	6	Tolleranza Tolerance
L	54	77.9	89.4	96.9	113.4	120.4	- 0.04	AO	4.5	5.5	12.5	12.5	17	17	
M	72.9	72.9	84.4	91.9	108.4	115.4	- 0.04	AP	15	15	20	20	26	26	
N	10	10	12	18	18	18	+ 0.02	AQ	16	18	26	26	29	30	
O	27	27	30	32	37	37	± 0.02	AR	18	24	26	34	31	38	
P	38	50	62	72.5	83	120		AS	11	17	17	17	21	21	
R	65	80	100	118	135	158		AT	11	11	13	13	13	17	
S	18	23	29	37.5	37.5	47.5		AU	35.5	35.5	38.5	41.5	47	47	
T	16	20.5	27.5	36.5	34	46		AV	M8	M10	M12	M12	M16	M16	
U	111	111	122.5	129	145	152		AW	75	95	125	145	170	195	
V	76	76	84.5	89	100	107	± 0.02	AX	20	23	28	28	34	38	
W	-	-	100	100	100	100		AY	50	62	88	100	120	133	
X	20	25	25	25	33.33	33.33		AZ	M10	M12	M14	M16	M20	M20	
Y	21	28	41	51	61	71	+ 0.02	BB	32	32	36	36	44	44	
Z	100	100	100	100	100	100		BC	96	121	146	171	196	296	
AA	10	12	13	15	20	20	- 0.02	BG	28	38	48	58	63	78	
AB	25.6	25.6	25.6	25.6	25.6	25.6	+ 0.02	BJ	50	60	80	90	100	120	
AC	31	41	57	70	80	90		BL	180	225	290	320	370	400	
AD	53	73	81	101	113	135		BM	9.5	9.5	11.5	11.5	17.5	17.5	
AF	13	18	18	18	18	18		CC	77	77	88.5	96	112	117	
AG	M10	M16	M16	M16	M20	M20		CD	48	58	78	88	98	117	
AH	62	80	90	116	138	184		CE	5	5	5	5	5	5	
AI	M10	M10	M12	M12	M12	M12		CF	-	-	64	64	71	-	
AJ	14	19	24	29	31.5	39		CG	-	-	100	100	128	-	
AK	38	38	50	50	76	240		CH	5.5	8	11	17	17	24	
AX	25,6	42,4	50,1	55,4	66,4	73,4		CI	24.5	32	39	43	48	56	
AL	42.4	42.4	50.9	55.4	66.4	73.4		CJ	12	12	13	13	18	18	
AM	4.5	5.5	12.5	12.5	17	17		CM	75	95	125	145	170	195	
AN	10	13	19	19	25	25									



1

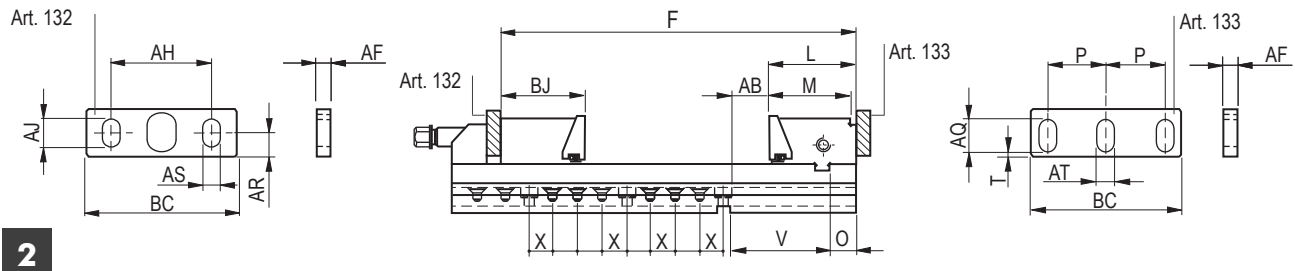

2

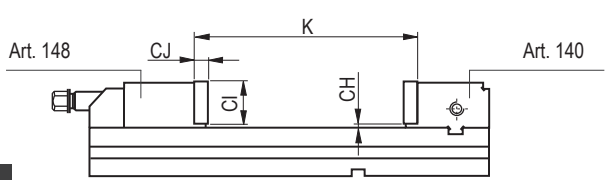

3

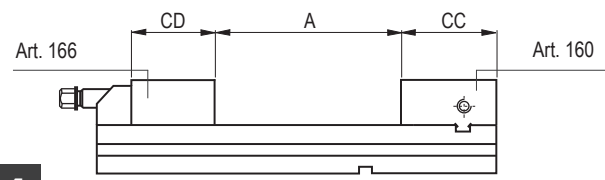

4

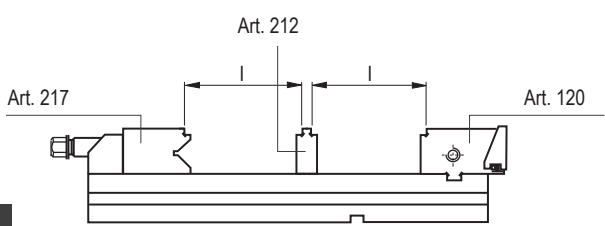

5

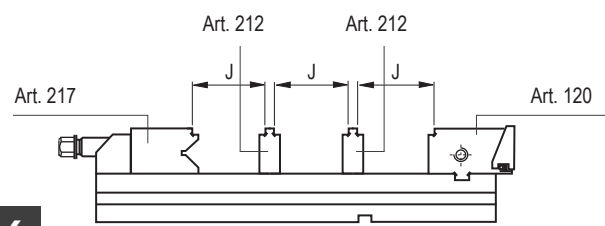

6

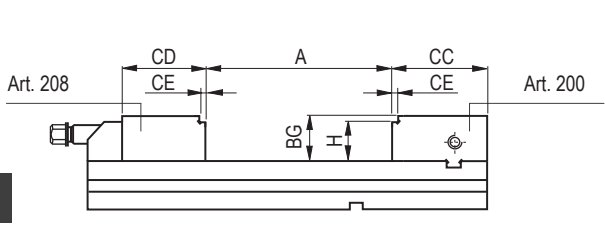

7

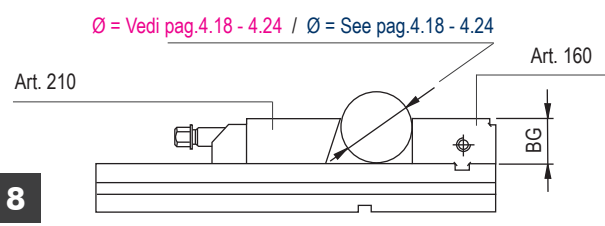

8

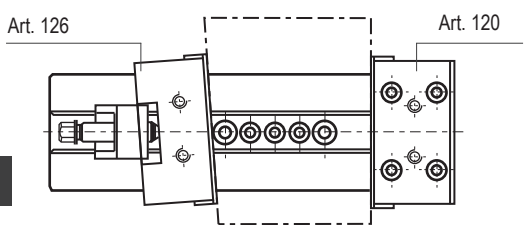

9

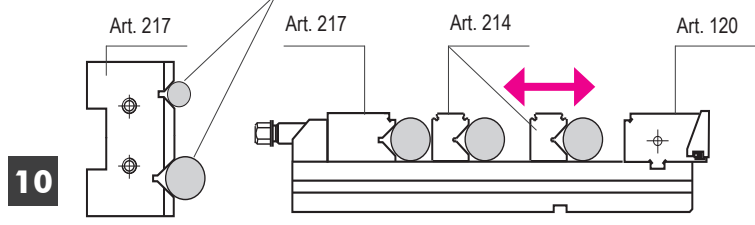

10

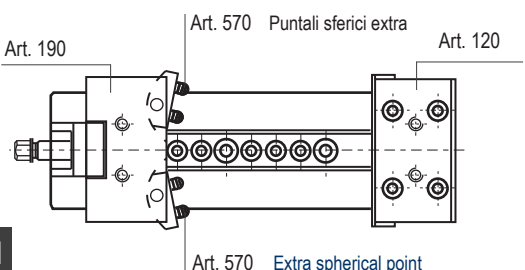

11

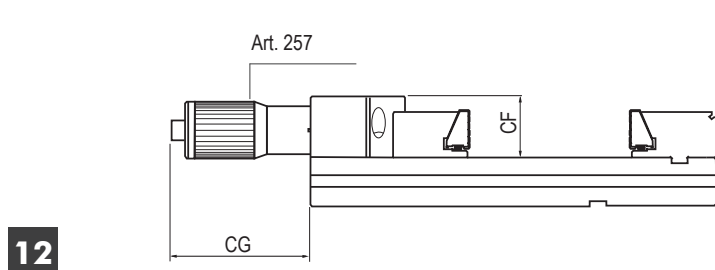

12

Tipo (grandezza) / Type (size)	1	2	3	4	5	6
Ganascia piana sovrapponibile fissa o mobile Straight stack-type jaw fixed or movable						
Art. 130* Art. 130S*						
Extra large / Extra width						
* Viti per fissaggio a richiesta Fixing screws on request						
	Cod. Art. 130	2.13.01000	2.13.02000	2.13.03000	2.13.04000	2.13.05000
	Cod. Art. 130S	2.13.0S100	2.13.0S200	2.13.0S300	2.13.0S400	2.13.0S500
	Cad / Each					
Ganascia sovrapponibile per pezzi tondi fissa o mobile Stack-type jaw round parts fixed or movable						
Art. 131* Art. 131S*						
Larghezza normale / Normal width						
* Viti per fissaggio a richiesta Fixing screws on request						
	Cod. Art. 131	2.13.11000	2.13.12000	2.13.13000	2.13.14000	2.13.15000
	Cod. Art. 131A	2.13.1A100	2.13.1A200	2.13.1A300	2.13.1A400	2.13.1A500
	Cad / Each					
	Cod. Art. 131S	2.13.1S100	2.13.1S200	2.13.1S300	2.13.1S400	2.13.1S500
	Cod. Art. 131AS	2.13.1AS10	2.13.1AS20	2.13.1AS30	2.13.1AS40	2.13.1AS50
	Cad / Each					
Ganascia piana sovrapponibile fissa o mobile Straight stack-type jaw fixed or movable						
Art. 136* Art. 136S*						
Larghezza normale / Normal width						
* Viti per fissaggio a richiesta Fixing screws on request						
	Cod. Art. 136	2.13.61000	2.13.62000	2.13.63000	2.13.64000	2.13.65000
	Cod. Art. 137	2.13.71000	2.13.72000	2.13.73000	2.13.74000	2.13.75000
	Cad / Each					
	Cod. Art. 136S	2.13.6S100	2.13.6S200	2.13.6S300	2.13.6S400	2.13.6S500
	Cod. Art. 137S	2.13.7S100	2.13.7S200	2.13.7S300	2.13.7S400	2.13.7S500
	Cad / Each					
Ganascia a squadra sovrapponibile fissa o mobile Square stack-type jaw fixed or movable						
Art. 138* Art. 138S*						
Larghezza normale / Normal width						
* Viti per fissaggio a richiesta Fixing screws on request						
	Cod. Art. 138	2.13.81000	2.13.82000	2.13.83000	2.13.84000	2.13.85000
	Cod. Art. 139	2.13.91000	2.13.92000	2.13.93000	2.13.94000	2.13.95000
	Cad / Each					
	Cod. Art. 138S	2.13.8S100	2.13.8S200	2.13.8S300	2.13.8S400	2.13.8S500
	Cod. Art. 139S	2.13.9S100	2.13.9S200	2.13.9S300	2.13.9S400	2.13.9S500
	Cad / Each					
Ganascia a squadra sovrapponibile doppia Double square jaw stack-type						
Art. 138D* Art. 138DS*						
Larghezza normale / Normal width						
* Viti per fissaggio a richiesta Fixing screws on request						
	Cod. Art. 138D	2.13.8D100	2.13.8D200	2.13.8D300	2.13.8D400	2.13.8D500
	Cod. Art. 139D	2.13.9D100	2.13.9D200	2.13.9D300	2.13.9D400	2.13.9D500
	Cad / Each					
	Cod. Art. 138DS	2.13.8DS10	2.13.8DS20	2.13.8DS30	2.13.8DS40	2.13.8DS50
	Cod. Art. 139DS	2.13.9DS10	2.13.9DS20	2.13.9DS30	2.13.9DS40	2.13.9DS50
	Cad / Each					
Ganascia prismatica sovrapponibile fissa o mobile Stack-type prismatic jaw fixed or movable						
Art. 150* Art. 150S*						
Larghezza normale / Normal width						
* Viti per fissaggio a richiesta Fixing screws on request						
	Cod. Art. 150	1.15.01000	1.15.02000	1.15.03000	1.15.04000	1.15.05000
	Cod. Art. 150A	1.15.0A100	1.15.0A200	1.15.0A300	1.15.0A400	1.15.0A500
	Cad / Each					
	Cod. Art. 150S	1.15.0S100	1.15.0S200	1.15.0S300	1.15.0S400	1.15.0S500
	Cod. Art. 150AS	1.15.0AS10	1.15.0AS20	1.15.0AS30	1.15.0AS40	1.15.0AS50
	Cad / Each					

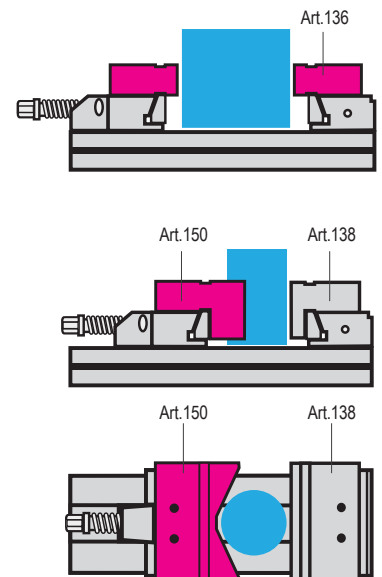
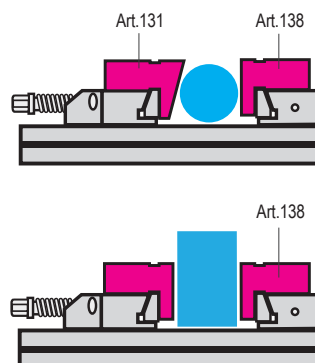
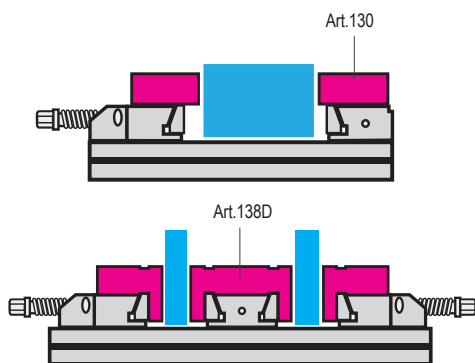
Versione "S" in acciaio lavorabile / "S" type in soft steel
Esempi applicativi - Application examples:

DIVISORE AUTOMATICO DPG 250

AUTOMATIC DIVIDING HEAD DPG 250

Divisore automatico
Automatic dividing head

Dati tecnici
Technical Data

DPG 250

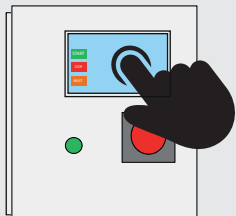
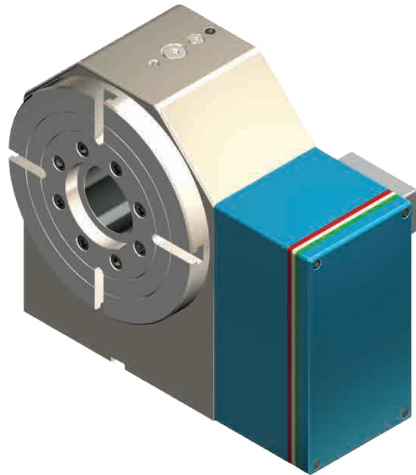

PROGRAMMAZIONE TOUCH SCREEN
FACILE ED INTUITIVA O TRAMITE COLLEGAMENTO
DIRETTO AL CNC

EASY AND INTUITIVE TOUCH SCREEN
PROGRAMMING OR THROUGH DIRECT
CONNECTION TO THE CNC

- Installazione semplice (alimentazione 220V)
- Corona in bronzo speciale
- Controsupporto semplice
- Vite senza fine in acciaio temprato e rettificato
- Vite e corona in bagno d'olio
- Cuscinetti a vite precaricati
- Cuscinetto anteriore a rulli incrociati sovradimensionato
- Recupero gioco con avvicinamento assiale
- Completa tenuta stagna ai liquidi con possibilità di pressurizzazione
- Possibilità di montare motori di tutte le marche
- Dimensioni esterne contenute
- Finestra di controlli liquidi e condensa
- Lavorazione in posizionamento a 360°

- Easy installation (220V)
- Special bronze crown
- Simple tailstock
- Worm screw in hardened ground steel
- Bath lubrication Screw and Crown
- Pre-loaded screw bearings
- Over-dimensioned crossed-roller front bearing
- Play recover with axial approach
- Watertight seal with possibility of pressurization
- Possibility to mount motors of all brands
- Reduced external dimensions
- Condensation and liquid control window
- 360° work positioning

Diametro del divisore Dividing head diameter		250 mm
Diametro del foro passante Clearance hole diameter		70,5 mm
Altezza punta Center height		200 mm
Dimensione della scanalatura a T T-Slot width		12 mm
Sistema di bloccaggio Clamping system		Idrraulico Hydraulic
Forza frenante Clamping torque		3000 Nm
Motore Servo motor		3000 Max.g/min
Minimo incremento Minimum increment		0,002
Velocità di rotazione Rotation speed		33,3 Giri/min
Rapporti vite/corona Speed reduction ratio (screw/gear)		1/90
Rapporti vite/motore Speed reduction ratio (screw/motor)		1/180
Precisione Indexing accuracy		±10 Sec.
Ripetibilità Repeatability		4 Sec.
Max. carico di lavoro sul divisore Max. allowable work weight on the dividing head	Verticale Vertical	Kg.550
	Orizzontale Horizontal	Kg.1500
Max. carico di spinta applicabile sul divisore Max. allowable tool load on the dividing head		N 25000
		FxL Nm 1000
		FxL Nm 2200
Rapporti vite/corona Speed reduction ratio (screw/gear)	Verticale Vertical	10,5 Kg. m ²
Coppia in lavoro Driving torque	Corona dentata Worm gear	698 Nm
Kg		110
Cod.		8.DP.G2500

DPG 250

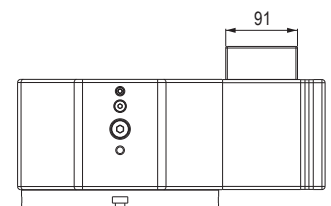
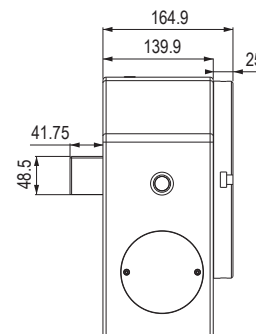
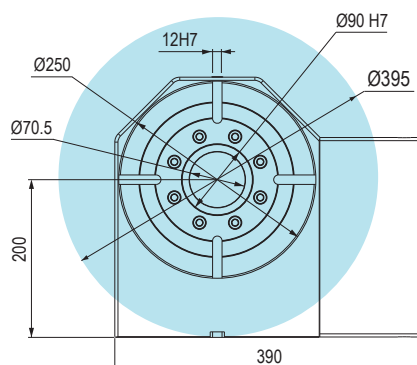

Tipo (grandezza) / Type (size) Montaggio / Mounting		1		2		3		4	
		Double		Double		Double		Double	
Apertura massima / Maximum spread	A	100	150	200	300	200	300	400	500
Divisore Gerardi PG250 con morse STD per il serraggio di particolari di tutte le forme e dimensioni.	W	96	121	146				171	
	B	28	38	48				58	
	C	35	40	50				58	
	D	270	345	420	520	455	555	655	755
	G	75	95	125				145	
	kg	7.3	13.2	26.2	29.7	37.9	43	48.1	53.2
	Cod.	1.DP.G25000	1.DP.G25010	1.DP.G25020	1.DP.G25030	1.DP.G25040	1.DP.G25050	1.DP.G25060	1.DP.G25070

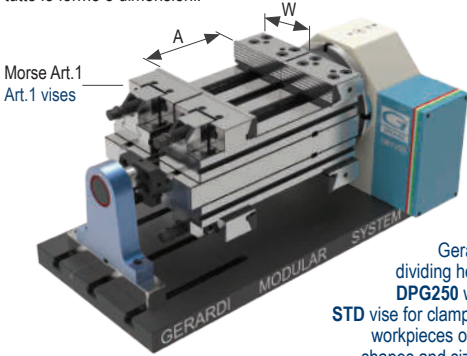

Gerardi dividing head DPG250 with STD vise for clamping workpieces of all shapes and sizes.

Nel caso si disponga di un proprio divisore, il prezzo dell'attrezzatura potrebbe subire variazioni
 In case you already have a diverger, the price may be revised

UPGRADE YOUR VISE APPLICATIONS THROUGH MODULAR ACCESSORIES !

Art. 99A
 Supporto
 Support



Cod. 7.99.A1000

Art. 99B
 Perno di centraggio completo di sistema d'allineamento
 Horizontal centering pin with alignment system



Cod. 1.99.B1000

Art. 99H
 Distanziale per supporto
 Spacer support



Cod. 1.99.H1000

Art. 62K
DPG 250
 Piastra di interfaccia per cubo STD completa di sistema d'allineamento
 Connecting plate with alignment system for STD



Cod. 1.62.KDPG25

Art. 99T
 Sovratavola per divisore
 Head-plate for dividing head



Cod. 1.99.T1000 1.99.T2000 1.99.T3200 1.99.T3300 1.99.T4200 1.99.T4300 1.99.T4400 1.99.T4500

Art. 99S
 Piastra base con cave
 Piani rettificati
 Base plate with slot
 Faces ground

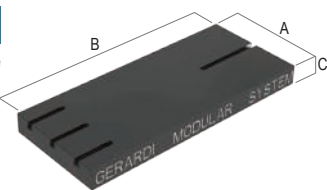

Dimensioni B mm Dimension B mm	A	C	Kg	Cod.
600	400	50	94	7.99.S060S
750	400	50	117	7.99.S075S
900	400	50	141	7.99.S090S
1100	400	50	172	7.99.S110S

Cave o fori calibrati su richiesta
 Slot or calibrated holes on request

Disponibili quote "B" a step di 50mm - Available dimension "B" in steps of 50mm

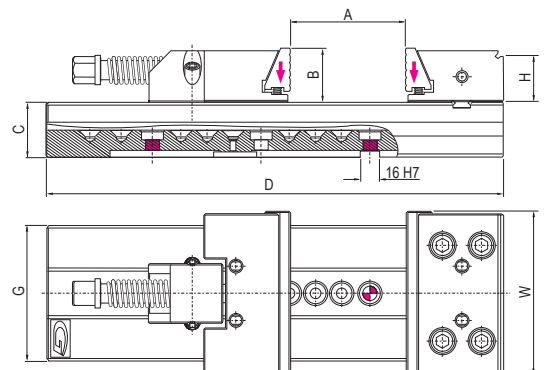
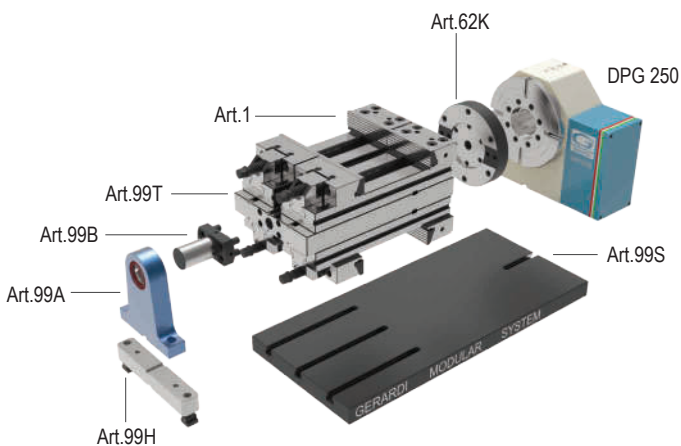

Vedi gruppo 4 per gamma completa accessori
 See group 4 for complete range of accessories

DIVISORE MECCANICO DIVIGER 205

MECHANICAL DIVIDING HEAD DIVIGER 205

Divisore automatico
Automatic dividing head

Dati tecnici
Technical Data

DIVIGER 205



Diametro del divisore Dividing head diameter	220 mm
Diametro del foro passante Clearance hole diameter	85 mm
Altezza centrale Center height	200 mm
Dimensione della scanalatura a T T-Slot width	-
Sistema di bloccaggio Clamping system	Meccanico Mechanical
Minimo incremento Minimum increment	1°
Precisione Indexing accuracy	±10 Sec.
Coppia in lavoro Driving torque	 3000 Nm
Kg	93
Cod.	7.66.73000

DIVISORE MECCANICO, SENZA CAVI O IDRAULICA,
PERMACCHINE A CNC

MECHANICAL DIVIDING HEAD, WITHOUT ELECTRICAL CABLES
OR HYDRAULIC, FOR CNC MILLING MACHINE

- Maggiore efficienza nella lavorazione su più lati
- Completamente autonomo dalla macchina
- Elevato momento torcente
- Divisione manuale o automatica tramite mandrino macchina
- 360 posizioni
- Serraggio simultaneo di due particolari grazie alla doppia flangia
- lavorazione su 5 facce senza contropunta
- Lavorazione a barra grazie al mandrino cavo
- Utilizzabile orizzontalmente o verticalmente
- Cambio tramite serraggio a cuneo
- Cost-effective on multiple-sides machining
- Machine independent
- High holding torque
- Dividing manually or automatically using the machine spindle
- 360 x 1° division
- Simultaneous clamping of 2 workpieces thanks to the dual flange
- 5 faces machining without counter-holder
- Bar machining due to hollow spindle
- To be used horizontally or vertically
- Quick change through wedge clamping

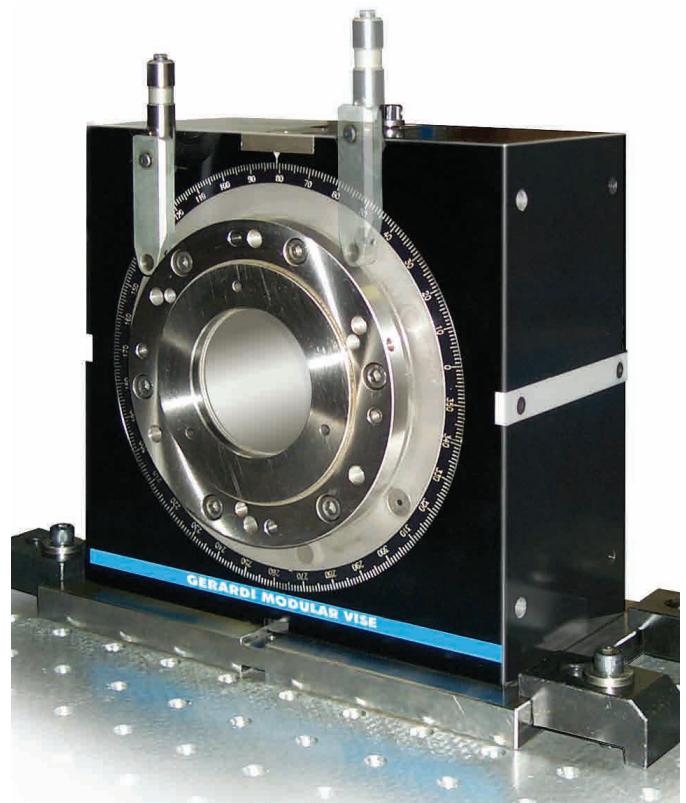

DIVIGER 205

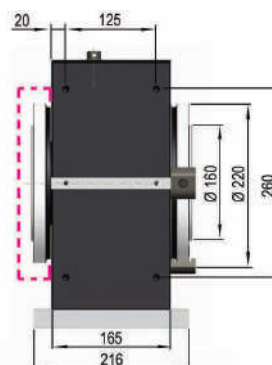
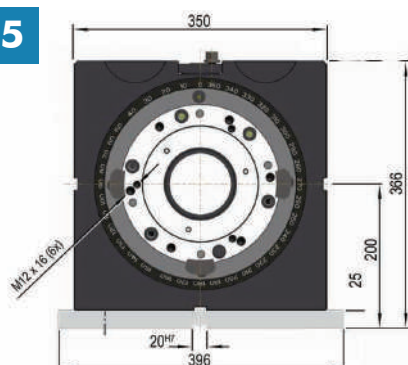

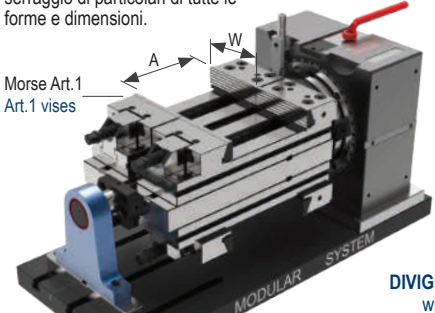
Tipo (grandezza) / Type (size)	1		2		3		4		
	Double	Double	Double	Double	Double	Double	Double	Double	Double
Apertura massima / Maximum spread	A	100	150	200	300	200	300	400	500
DIVIGER 205 con morse STD per il serraggio di particolari di tutte le forme e dimensioni. 	W	96	121	146		171			
	B	28	38	48		58			
	C	35	40	50		58			
	D	270	345	420	520	455	555	655	755
	G	75	95	125		145			
Cod.	1.Di.V20500	1.Di.V20510	1.Di.V20520	1.Di.V20530	1.Di.V20540	1.Di.V20550	1.Di.V20560	1.Di.V20570	

DIVIGER 205 with **STD** vise for clamping workpieces of all shapes and sizes.

Nel caso si disponga di un proprio divisore, il prezzo dell'attrezzatura potrebbe subire variazioni
 In case you already have a divider, the price may be revised

UPGRADE YOUR VISE APPLICATIONS THROUGH MODULAR ACCESSORIES !
Art. 99A

 Supporto
 Support

Cod. 7.99.A1000

Art. 99B

 Perno di centraggio completo di sistema d'allineamento
 Horizontal centering pin with alignment system

Cod. 1.99.B1000

Art. 99H

 Distanziale per supporto
 Spacer support

Cod. 1.99.H1000

Art. 62K
DIVIGER 205
 Piastra di interfaccia per cubo STD completa di sistema d'allineamento
 Connecting plate with alignment system for STD

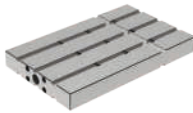

Cod. 1.62.KDPC25

Art. 99T

 Sovratavola per divisore
 Head-plate for dividing head

Cod. 1.99.T1000 1.99.T2000 1.99.T3200 1.99.T3300 1.99.T4200 1.99.T4300 1.99.T4400 1.99.T4500

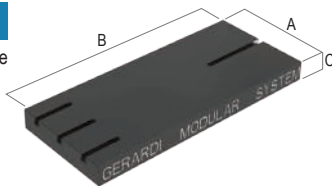
Art. 99S

 Piastra base con cave
 Piani rettificati
 Base plate with slot
 Faces ground

Dimensioni B mm Dimension B mm	A	C	Kg	Cod.
600	400	50	94	7.99.S060S
750	400	50	117	7.99.S075S
900	400	50	141	7.99.S090S
1100	400	50	172	7.99.S110S

 Cave o fori calibrati su richiesta
 Slot or calibrated holes on request

Disponibili quote "B" a step di 50mm - Available dimension "B" in steps of 50mm

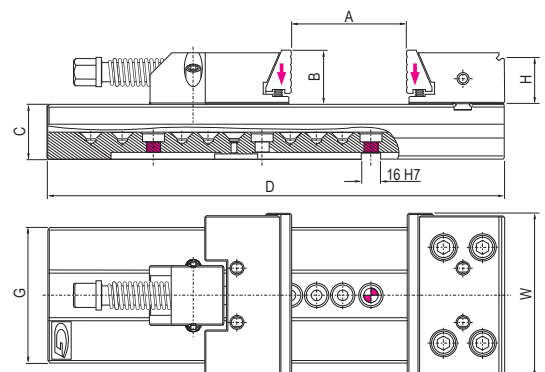
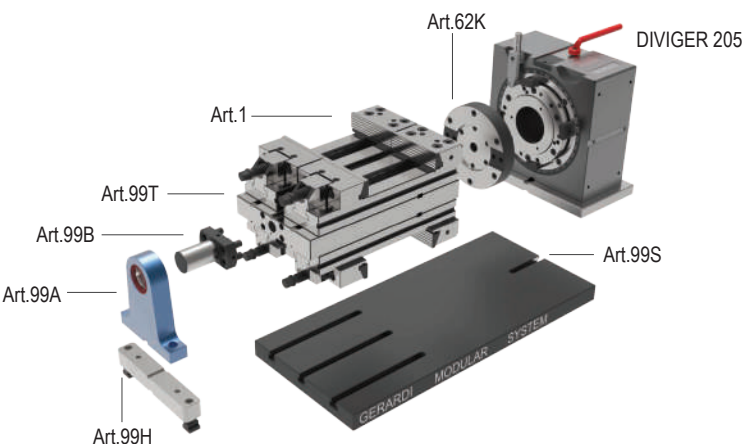
 Vedi gruppo 4 per gamma completa accessori
 See group 4 for complete range of accessories

1

PREDISPOSIZIONE e MONTAGGIO MORSE su CUBI LAVORATI

TOMBSTONES SET-UP and VISES MOUNTING on MACHINED TOMBSTONES

Art. 53C
Cubo lavorato
 Machined cube

Dim. A=350 / B=500 / H=700

Cod. 8.53.C00171

Art. 1
Tipo di morsa
 Vise type



Art.1 Type 4x300

Cod. 3.04.30000

Numero morsa x **4**
 Vises number

Predisposizione e montaggio completo

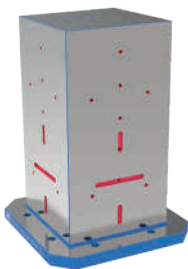
Complete set up & mounting



Cod. MAN-040-STD

Realizzazione di fori filettati o fori di fissaggio (da un minimo di 4 a un massimo di 6), fori calibrati o chiavette (da un minimo di 2 a un massimo di 3).
 Creation of threaded holes or screw holes (minimum 4 and maximum 6), calibrated holes or key-ways (minimum 2 and maximum 3).

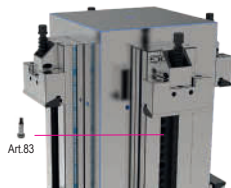
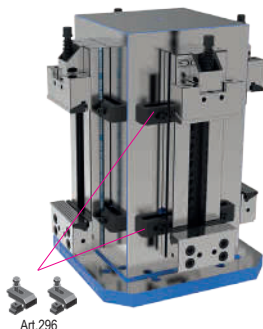
Cubo con morsa
 Cube with vises

 TABULATO controllo DEA - MAN-100-STD
 PRINTOUT DEA control - MAN-100-STD

MONTAGGIO MORSE in VERTICALE su SUPPORTO CENTRALE

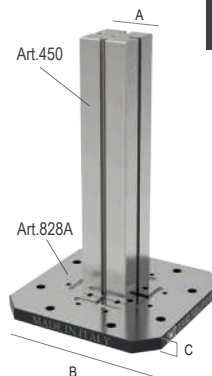
VISE VERTICAL MOUNTING on CENTRAL SUPPORT

Supporto centrale + Piastra base
 Center support + Head plate

 Art.450
 Dim. A=125 / H=520

 Art.828A
 Dim. B=400 / C=38

Cod. 1.45.03520

Cod. 1.82.8A300

Art. 1
Tipo di morsa
 Vise type



Art.1 Type 3x300

Cod. 3.03.30000

Numero morsa x **4**
 Vises number

Montaggio verticale completo

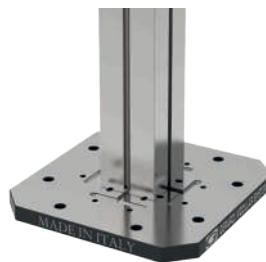
Vertical (complex) Assembly



Cod. MAN-080-STD

Montaggio di una o più morsa e/o attrezzature. Il prezzo di listino comprende manodopera, viti, staffe e tasselli per singola morsa.
 Assembly of one or more vises and/or equipment. The list price includes working hours, screws, holding clamps and key-nuts for only one vise.

Art. 750
Cubo con morsa
 Cube with vises

Art.750 Type 3x300

Cod. 1.75.03300

 TABULATO controllo DEA - MAN-100-STD
 PRINTOUT DEA control - MAN-100-STD

CONTROLLO ALLINEAMENTO TRA CAVA TRASVERSALE E GANASCIA FISSA

ALIGNEMENT BETWEEN THE CROSS KEYWAY AND THE FIXED JAW PLATE



Libretto Istruzioni / Instruction Book

Scansiona il QR code e scarica le istruzioni complete

Scan the QR code to download the complete instructions

Posizionare la morsa verticalmente assicurandosi che sia perfettamente parallela al piano di appoggio **A** nei due sensi. Successivamente, con un comparatore centesimale, controllare il parallelismo del piano cava e della ganascia fissa.

Set the vise vertically ensuring that it is perfectly at parallel to the table **A** in both sides. Then with an indicator check the parallelism of the keyway and its alignment with the fixed jaw plate.

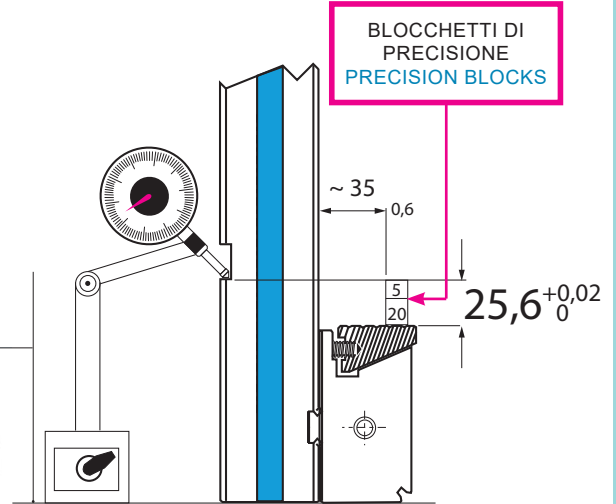
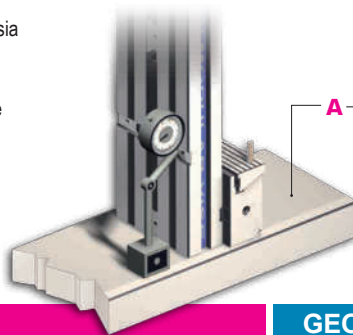

TOLLERANZE GEOMETRICHE

GEOMETRIC ACCURACIES

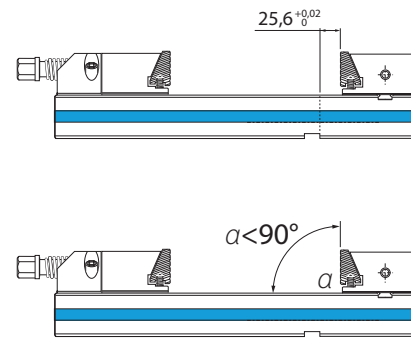
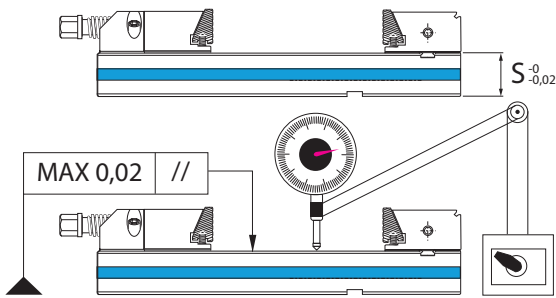

TOLLERANZE DINAMICHE

DYNAMIC ACCURACIES

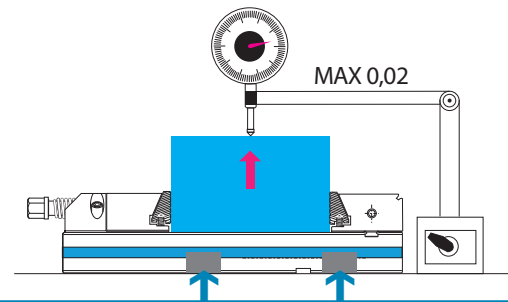
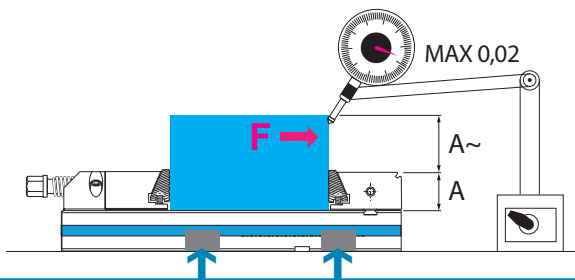

Morsa ancorata con 2 coppie di staffe Art.296 / Vise clamped with n. 2 pairs of Art.296

Valori di flessione nel punto "A" in relazione alle forze di serraggio **PER MORSE TIPO 3**
 Deflection values at "A" in relation to clamping powers **FOR TYPE 3 VISES**

1 kgf . m = 9.806 Nm

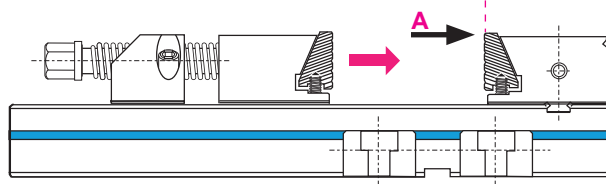

Kn	mm
60	0.1
50	0.07
40	0.05
30	0.03
20	0.02
10	0.01
5	0.004
2	0.002

Il sistema consigliato per l'ancoraggio della morsa sulla tavola macchina è tramite **STAFFE Art.296**. (Fig.1)

E' possibile ancorare la morsa tramite viti centrali, ma in questo caso la quota X potrebbe flettere e compromettere lo scorrimento della ganascia mobile. (Fig.2)

Nella tabella seguente sono riportati i valori di coppia massima applicabile mediante chiave dinamometrica

We recommend to fix the vises to the machine table using clamps Art. 296. (Fig. 1) The vise can be also fixed by means of central screws, but, this way, the X quota may suffer a bending and compromise the sliding of the movable jaws. (Fig. 2)

In the following table you can find the maximum torque values applicable through torque wrench.

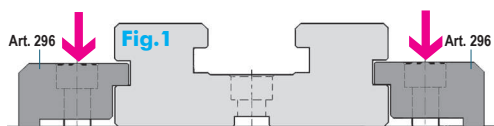

Vite Screw	M8	M10	M12	M16
Torque Nm	40	80	140	345

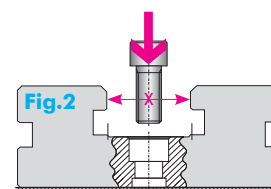

Type	1	2	3	4	5	6
Torque Nm	18	40	140	140	250	250
Viti - Screws	2	2	3	4	4	4

Diagrammi di serraggio / Clamping diagrams

Standard / StandardFLEX

Diagrammi di serraggio meccanico con chiave dinamometrica

Mechanical clamping diagrams with torque wrench

Art. 1 / 1A / 700

Morse tipo 1

Vite M12 - Passo 1,75mm - Screw M12 - Pitch 1,75mm

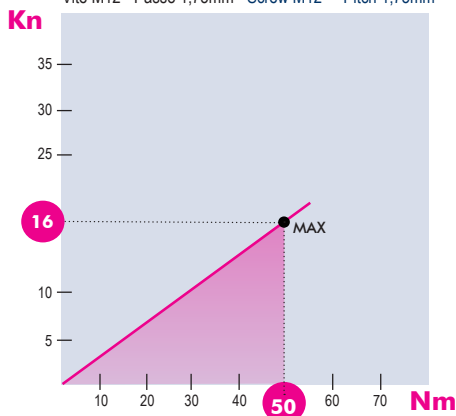

Art. 357

Morse tipo 2

Vite TPN18 - Passo 4mm - Screw TPN18 - Pitch 4mm

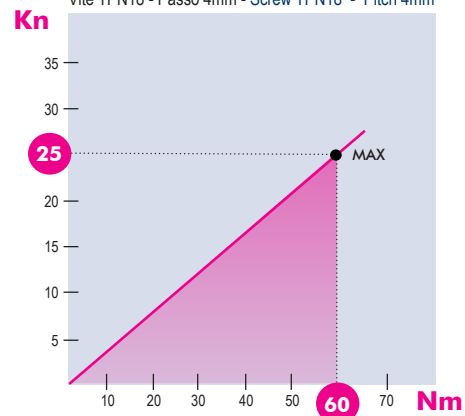

Gruppi di serraggio meccanici (Art. 258 e simili) / Mechanical clamping devices (Art. 258 and similar)

I diagrammi seguenti consentono di determinare le forze di serraggio ottenibili con le morse di varia grandezza (da 1 a 6), in funzione del momento applicato
 The following diagrams give the clamping force that can be obtained with each vise type (size 1 to 6) depending on the torque

Morse tipo 3-4

Vite TPN24 - Passo 5mm - Screw TPN24 - Pitch 5mm

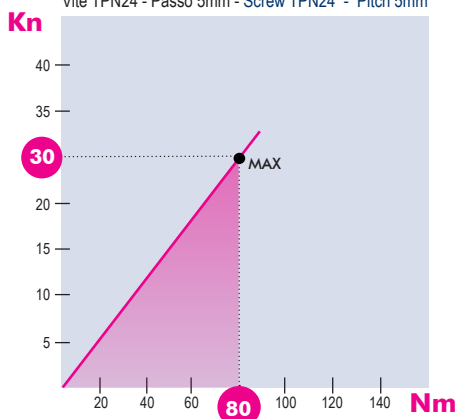

Art. 357

Morse tipo 5-6

Vite TPN30 - Passo 5mm - Screw TPN30 - Pitch 5mm

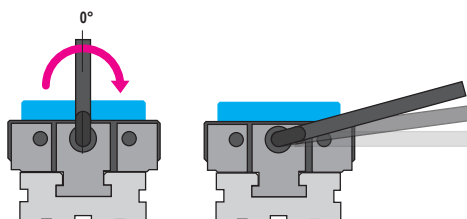
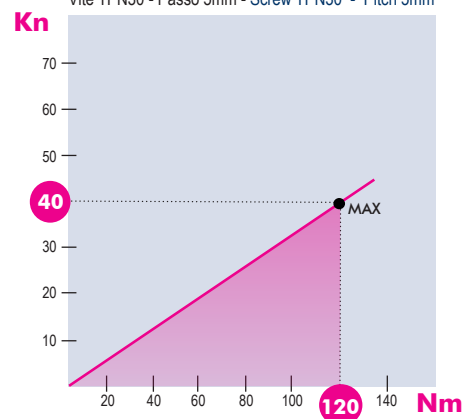

Serrare il pezzo agendo sulla vite di spinta con la chiave in dotazione senza utilizzare tubi o martelli.
 Attenzione: nel serraggio basta 1/4 di giro della chiave dal momento in cui la ganaschia tocca il particolare.

Clamp the workpiece turning clockwise the main spindle through the box wrench without using tubes or hammers. Attention: for the right clamping operation 1/4 of a turn of the box wrench is enough

Type (Size)	1	2	3	4	5	6
Kn	12	26	36	46	50	50

Valori indicativi Kn raggiunte a 90°
 Kn indicative values at 90°

NB: Alcuni fattori, come la lubrificazione, lo staffaggio, gli attriti ed altro, possono modificare i valori indicati fino a ± 10%. Per un corretto utilizzo non superare i valori indicati nel grafico
 Some factor as lubrication, clamping on the machine table, frictions and more can modify above values within a ± 10% range. For optimum operation do not exceed chart values.

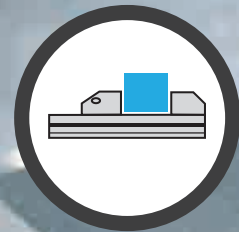

1

90° max

*For the highest accuracy
machining operations*

OK

3 MICRONS ACCURACY

Morse e Cubi / Vises & Vise Towers

Morse / Vises

OK series

 Precisione / Accuracy
±0,005mm

 Durezza / Hardened
HRC 60
Morse di precisione per rettifica!
Highest accuracy vises for grinding operations!
CARATTERISTICHE & VANTAGGI

- ✓ SUPERFICI RETTIFICATE, TEMPRATE E LAPPATE
- ✓ ORTOGONALITÀ E PARALLELISMO 0,003mm / 100mm
- ✓ IDEALI PER OPERAZIONI DI CONTROLLO, RETTIFICA, ELETTROEROSIONE E FRESATURA

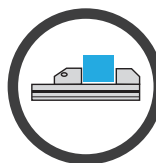
TECHNICAL FEATURES & ADVANTAGES

- ✓ ALL CASE HARDENED AND HARDENED HRC 60 STEEL
- ✓ SQUARENESS AND PARALLELISM: 0.003mm / 100mm
- ✓ IDEAL FOR GRINDING E.D.M MACHINE AND FOR MILLING OPERATIONS ALSO FOR CHECKING AND CONTROL

Per le esigenze più impegnative nelle lavorazioni con ristrette tolleranze

For the highest accuracy machining operations

Rigidità & Sicurezza
Rigidity & Safety

La ganaschia fissa e la base delle morse OK sono integrali e costruite in corpo unico per garantire una maggiore rigidità e nessuna flessione durante le lavorazioni.

The fixed jaw and the base of the OK vises are built in one solid pieces in order to guarantee higher rigidity & no bendings during the machinings

Guide esterne
External Guides

A differenza della guida centrale che consente un'importante oscillazione della ganaschia, la guida esterna garantisce uno scorrimento più lineare e preciso, garantendo così il parallelismo dei piani delle ganasce fissa e mobile.

Differently from the central guide that allows a significant jaw tilting, the external guide grants a linear and accurate sliding thus ensuring the parallelism of the fixed and movable jaws surfaces.

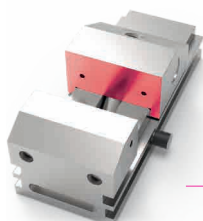
Fissaggio morse OK
Fixing OK vise

La morsa viene bloccata sulla tavola macchina grazie a due coppie di staffe di fissaggio complete di vite e tassello a "T"

The OK vise is clamped on the machine table by two pair of vise holding clamps complete of screw and "T" nut

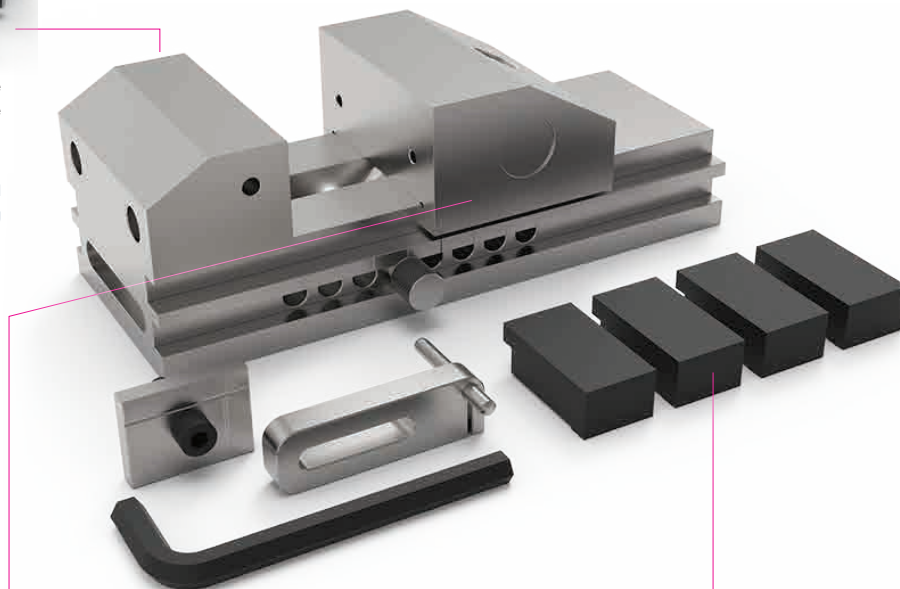

Staffe d'ancoraggio / Vise holding clamps

OK Series

Coppia staffe di fissaggio Art.666O, complete di vite e dado a "T"

Pair of vise holding clamps Art.666O complete of screw and "T" nuts



Esempio d'ordine per morsa tipo 3 su macchina con cave a T da 18mm: Art.666O T.3 X=18mm*

Oppure con codice: 7.66.6O300*

Order example for Type 3 vise on machine with 18mm T-slots: Art.666O T.3 X=18mm*

Also with code: 7.66.6O300*

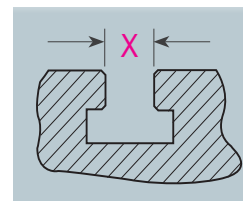

Cava a T

T Slot

Specificare sempre la cava della vostra macchina

Always specify the machine T-slot dimension

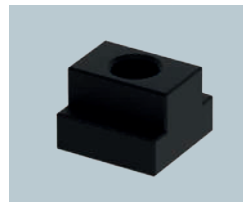

Art.287 (Pag.4.34)*

Dadi a T - T Nuts

Per fissaggio morsa alle cave a T della macchina

For vise clamping on the machine T-slots

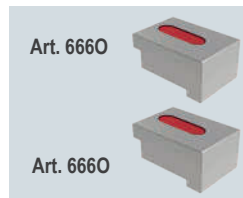

Art.666O

Consigliate 2 coppie di staffe Art.666O per ogni morsa

Suggested 2 pairs of holding clamps Art.666O for each vise

* Dadi a T (Art.287) e viti TCEI a richiesta - T-Nuts (Art.287) & HS screws on request

Tipo (grandezza) morsa Vise type (size)		0	1	2	3	4 - 5 - 6	7	8
Art. 666O Coppia di staffe Holding clamps pair	Tipo (grandezza) Type (size)	T0	T1	T2	T3	T4	T7	T8
	A	36	50	60,5	60,5	65	65	80
	B	8,5	15,4	19,6	23,4	27,5	37	35
	C	3	5	6	8	9,5	10	12
	H	14	25	30	30	30	30	40
	J	1	1,2	1,2	1,2	1,2	1	1
	T	3	8	10	12	14	24	18
	Cod.	7.66.6O000	7.66.6O100	7.66.6O200	7.66.6O300	7.66.6O400/ 500/600	7.66.6O700	7.66.6O800

Staffe completamente lavorabile
Completely machineable clamp

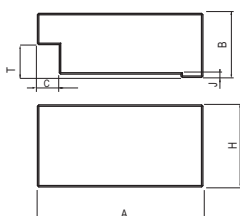
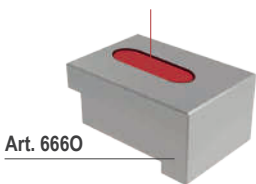

Tipo (grandezza) morsa / Vise type (size)	kN	0	1	2	3	4	5	6	7	8
				16 kN	16 kN	18 kN	18 kN	18 kN	18 kN	20 kN
Apertura massima / Maximum spread	A	27	80	100	120	160	180	200	260	200
	W	30	60	75	100	125	125	125	125	160
	B	15	28	40	45	50	50	50	50	63
	C	15	28	35	42	50	50	50	50	63
	D	75	175	220	260	330	350	370	430	410
	E	15	40	50	55	65	65	65	65	80
	F	33	55	50	85	105	105	105	110	130
	kg	0,28	2,820	5,820	10,740	19,450	20,080	20,720	26,720	38
	Cod.	3.66.60000	3.66.61000	3.66.62000	3.66.63000	3.66.64000	3.66.65000	3.66.66000	3.66.67000	3.66.68000

Art. 666

Morsa serie OK in acciaio / Series OK vises in steel

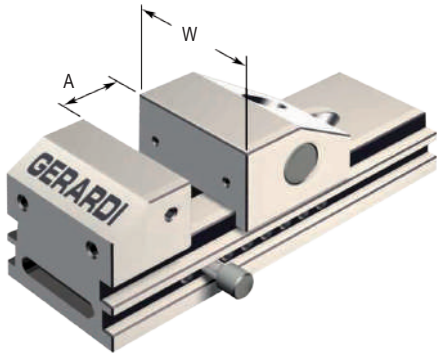

Art. 666S

 Morsa serie OK in acciaio INOX Tipo *X39 Cr13 per elettroerosione. Stesse caratteristiche dell'Art. 666
 Series OK vises in INOX steel Type *X39 Cr13 for E.D.M. machines. Same features and dimension of the Art. 666

 * Acciaio temprato a basso contenuto di ferro (Max resistenza alla corrosione dopo tempra e rettifica)
 Low carbon hardened steel (max resistance against corrosion after hardening process and grinding operations)

Cod. 3.66.6S000 3.66.6S100 3.66.6S200 3.66.6S300 3.66.6S400 3.66.6S500 3.66.6S600 3.66.6S700 3.66.6S800

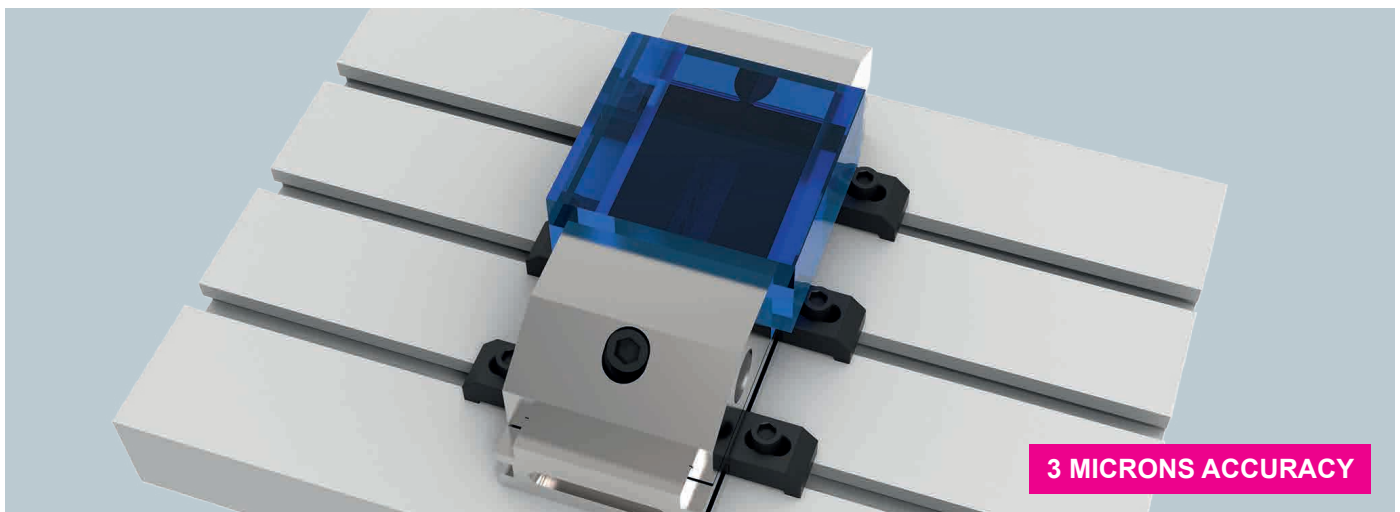

Dotazione standard:

- 4 staffe di fissaggio Art. 666O
- 1 arresto laterale fisso Art. 666G (NON FORNITO con morsa Tipo 0) ■ 1 arresto laterale mobile Art. 666I

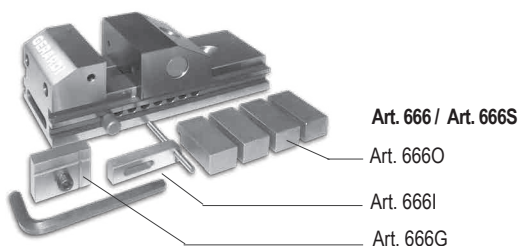

Standard equipment:

- 4 clamping jaws Art. 666O
- 1 fixed work stop Art. 666G (NOT INCLUDED with Type 0 vises) ■ 1 movable work stop Art. 666I

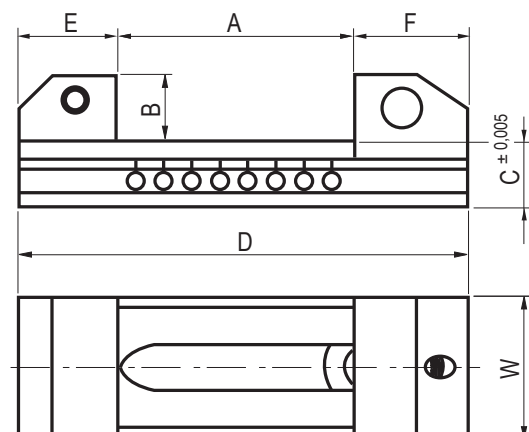

Tipo (grandezza) morsa / Vise type (size)	0	1	2	3	4	5	6	7	8	
			16 kN	16 kN	18 kN	18 kN	18 kN	18 kN	20 kN	
Parti di ricambio per Art. 666 / Spare parts for Art. 666										
	Art. 666A	Cod. 7.66.6A000	7.66.6A100	7.66.6A200	7.66.6A300	7.66.6A400	7.66.6A500	7.66.6A600	7.66.6A700	7.66.6A800
	Art. 666B	Cod. 7.66.6B000	7.66.6B100	7.66.6B200	7.66.6B300	7.66.6B400	7.66.6B500	7.66.6B600	7.66.6B700	7.66.6B800
	Art. 666C	Cod. 7.66.6C000	7.66.6C100	7.66.6C200	7.66.6C300	7.66.6C400	7.66.6C500	7.66.6C600	7.66.6C700	7.66.6C800
	Art. 666D	Cod. 7.66.6D000	7.66.6D100	7.66.6D200	7.66.6D300	7.66.6D400	7.66.6D500	7.66.6D600	7.66.6D700	7.66.6D800
	Art. 666E	Cod. 7.66.6E000	7.66.6E100	7.66.6E200	7.66.6E300	7.66.6E400	7.66.6E500	7.66.6E600	7.66.6E700	7.66.6E800
	Art. 666F	Cod. 7.66.6F000	7.66.6F100	7.66.6F200	7.66.6F300	7.66.6F400	7.66.6F500	7.66.6F600	7.66.6F700	7.66.6F800
	Art. 666G	Cod. 7.66.6G000	7.66.6G100	7.66.6G200	7.66.6G300	7.66.6G400	7.66.6G500	7.66.6G600	7.66.6G700	7.66.6G800
	Art. 666H	Cod. 7.66.6H000	7.66.6H100	7.66.6H200	7.66.6H300	7.66.6H400	7.66.6H500	7.66.6H600	7.66.6H700	7.66.6H800
	Art. 666I	Cod. 7.66.6I000	7.66.6I100	7.66.6I200	7.66.6I300	7.66.6I400	7.66.6I500	7.66.6I600	7.66.6I700	7.66.6I800
	Art. 666L	Cod. 7.66.6L000	7.66.6L100	7.66.6L200	7.66.6L300	7.66.6L400	7.66.6L500	7.66.6L600	7.66.6L700	7.66.6L800
	Art. 666M	Cod. 7.66.6M000	7.66.6M100	7.66.6M200	7.66.6M300	7.66.6M400	7.66.6M500	7.66.6M600	7.66.6M700	7.66.6M800
	Art. 666N	Cod. 7.66.6N000	7.66.6N100	7.66.6N200	7.66.6N300	7.66.6N400	7.66.6N500	7.66.6N600	7.66.6N700	7.66.6N800
	Art. 666O	Cod. 7.66.6O000	7.66.6O100	7.66.6O200	7.66.6O300	7.66.6O400	7.66.6O500	7.66.6O600	7.66.6O700	7.66.6O800

Tipo (grandezza) morsa / Vise type (size)	0	1	2	3	4	5	6	7	8	
			16 kN	16 kN	18 kN	18 kN	18 kN	18 kN	20 kN	
Parti di ricambio in acciaio inox per Art. 666S / Spare parts in stainless steel for Art. 666										
	Art. 666AS	Cod. 7.66.6AS00	7.66.6AS10	7.66.6AS20	7.66.6AS30	7.66.6AS40	7.66.6AS50	7.66.6AS60	7.66.6AS70	7.66.6AS80
	Art. 666BS	Cod. 7.66.6BS00	7.66.6BS10	7.66.6BS20	7.66.6BS30	7.66.6BS40	7.66.6BS50	7.66.6BS60	7.66.6BS70	7.66.6BS80
	Art. 666CS	Cod. 7.66.6CS00	7.66.6CS10	7.66.6CS20	7.66.6CS30	7.66.6CS40	7.66.6CS50	7.66.6CS60	7.66.6CS70	7.66.6CS80
	Art. 666DS	Cod. 7.66.6DS00	7.66.6DS10	7.66.6DS20	7.66.6DS30	7.66.6DS40	7.66.6DS50	7.66.6DS60	7.66.6DS70	7.66.6DS80
	Art. 666ES	Cod. 7.66.6ES00	7.66.6ES10	7.66.6ES20	7.66.6ES30	7.66.6ES40	7.66.6ES50	7.66.6ES60	7.66.6ES70	7.66.6ES80
	Art. 666FS	Cod. 7.66.6FS00	7.66.6FS10	7.66.6FS20	7.66.6FS30	7.66.6FS40	7.66.6FS50	7.66.6FS60	7.66.6FS70	7.66.6FS80
	Art. 666GS	Cod. 7.66.6GS00	7.66.6GS10	7.66.6GS20	7.66.6GS30	7.66.6GS40	7.66.6GS50	7.66.6GS60	7.66.6GS70	7.66.6GS80
	Art. 666HS	Cod. 7.66.6HS00	7.66.6HS10	7.66.6HS20	7.66.6HS30	7.66.6HS40	7.66.6HS50	7.66.6HS60	7.66.6HS70	7.66.6HS80
	Art. 666IS	Cod. 7.66.6IS00	7.66.6IS10	7.66.6IS20	7.66.6IS30	7.66.6IS40	7.66.6IS50	7.66.6IS60	7.66.6IS70	7.66.6IS80
	Art. 666LS	Cod. 7.66.6LS00	7.66.6LS10	7.66.6LS20	7.66.6LS30	7.66.6LS40	7.66.6LS50	7.66.6LS60	7.66.6LS70	7.66.6LS80
	Art. 666MS	Cod. 7.66.6MS00	7.66.6MS10	7.66.6MS20	7.66.6MS30	7.66.6MS40	7.66.6MS50	7.66.6MS60	7.66.6MS70	7.66.6MS80
	Art. 666NS	Cod. 7.66.6NS00	7.66.6NS10	7.66.6NS20	7.66.6NS30	7.66.6NS40	7.66.6NS50	7.66.6NS60	7.66.6NS70	7.66.6NS80
	Art. 666OS	Cod. 7.66.6OS00	7.66.6OS10	7.66.6OS20	7.66.6OS30	7.66.6OS40	7.66.6OS50	7.66.6OS60	7.66.6OS70	7.66.6OS80

MORSE per RETTIFICA

GRINDING VISES

3 MICRONS ACCURACY
Una morsa estremamente precisa, adatta a lavorazioni di rettifica
High precision vise ideal for grinding operations

- Particolarmente adatta per lavori di alta precisione su rettificatrici e apparecchiature di controllo
- Costruita completamente in acciai temprati a durezza 58/60 HRC
- Perfettamente rettificata su tutti i suoi piani onde per ottenere i 90° in ogni posizione desiderata
- La ganaschia mobile ha due V ortogonali per bloccare pezzi cilindrici
- Tolleranze millesimali: ± 0.003 mm.

- Ideal for high-precision grinding machines or for inspection work
- Entirely made of non-deformable alloy steel hardened to 58/60 HRC
- Perfectly ground surfaces in order to reach 90° in any position
- The movable jaw has two prismatic surfaces in order to clamp round workpieces
- Accuracy: ± 0.003 mm

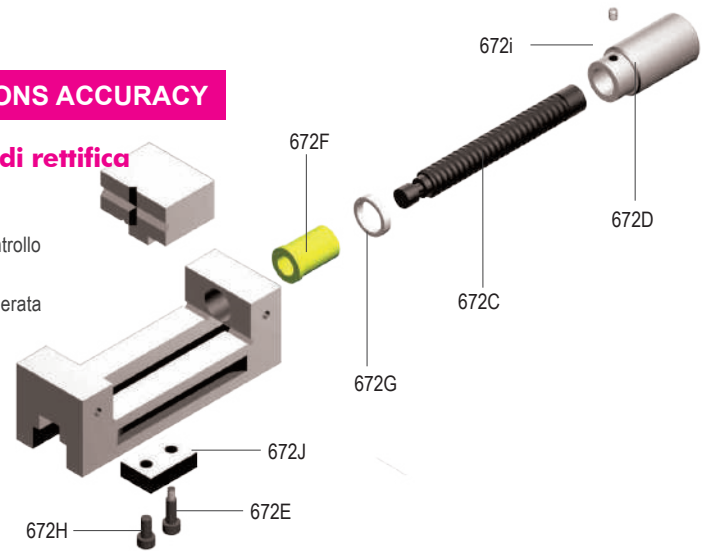

Tipo (grandezza) morsa / Vise type (size)		1	2	3	4	5	6	7
Apertura massima / Maximum spread	A	64	76	88	100	120	160	175
	W	50	64	76	88	100	125	150
	B	30	35	35	40	40	50	50
	C	60	70	70	75	75	98	98
	D	150	172	187	215	240	290	305
	E	30	30	32	40	40	50	50
	F	35	40	40	45	45	50	50
	H	190	212	227	255	280	338	355
	kg	2,2	3,9	5,4	7	8,8	15,7	20
	Cod.	1.67.21000	1.67.22000	1.67.23000	1.67.24000	1.67.25000	1.67.26000	1.67.27000

Art. 672

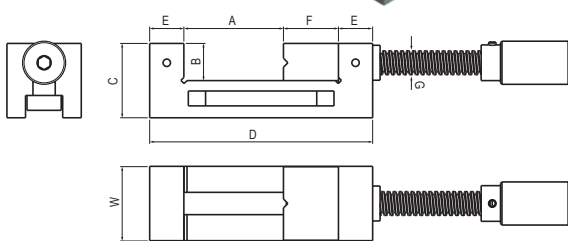
 Morsa serie OK in acciaio
 Series OK vises in steel

Tipo (grandezza) morsa / Vise type (size)		1	2	3	4	5	6	7
Base Morsa Vise Base	Art. 672A	Cod. 1.67.2A100	1.67.2A200	1.67.2A300	1.67.2A400	1.67.2A500	1.67.2A600	1.67.2A700
Ganaschia Mobile Movable Jaw	Art. 672B	Cod. 1.67.2B100	1.67.2B200	1.67.2B300	1.67.2B400	1.67.2B500	1.67.2B600	1.67.2B700
Vite di Spinta Main Screw	Art. 672C	Cod. 1.67.2C100	1.67.2C200	1.67.2C300	1.67.2C400	1.67.2C500	1.67.2C600	1.67.2C700
Impugnatura Vite Handle screw	Art. 672D	Cod. 1.67.2D100	1.67.2D200	1.67.2D300	1.67.2D400	1.67.2D500	1.67.2D600	1.67.2D700
Vite calibrata ganaschia mobile Movable jaw shoulder screw	Art. 672E	Cod. 1.67.2E100	1.67.2E200	1.67.2E300	1.67.2E400	1.67.2E500	1.67.2E600	1.67.2E700
Boccola Bushing	Art. 672F	Cod. 1.67.2F100	1.67.2F200	1.67.2F300	1.67.2F400	1.67.2F500	1.67.2F600	1.67.2F700
Ghiera Nut	Art. 672G	Cod. 1.67.2G100	1.67.2G200	1.67.2G300	1.67.2G400	1.67.2G500	1.67.2G600	1.67.2G700
Vite Screw	Art. 672H	Cod. 1.67.2H100	1.67.2H200	1.67.2H300	1.67.2H400	1.67.2H500	1.67.2H600	1.67.2H700
Vite Screw	Art. 672I	Cod. 1.67.2I100	1.67.2I200	1.67.2I300	1.67.2I400	1.67.2I500	1.67.2I600	1.67.2I700
Pattino ganaschia mobile Sliding plate for movable jaw	Art. 672J	Cod. 1.67.2J100	1.67.2J200	1.67.2J300	1.67.2J400	1.67.2J500	1.67.2J600	1.67.2J700

Tipo (grandezza) morsa / Vise type (size)	1	2	3	
Apertura massima / Maximum spread	A	100	120	160
Art. 667 Morse di precisione con barraseno (0 - 90°) Precision sine vises (0 - 90°)	W	75	100	125
	B	32	45	50
	C	95	116	139
	D	214	244	303,5
	E	150	200	240
	kg	9	15	26
	Cod.	1.66.71000	1.66.72000	1.66.73000

- Superfici rettificate, temperate e lappate
- **Ortogonalità e parallelismo: 0,003 mm / 100 mm**
- Ideali per operazioni di controllo, rettifica, elettroerosione e fresatura
- All case hardened and hardened HRC 60 steel
- **Squareness and parallelism: 0,003 mm / 100 mm**
- Ideal for grinding E.D.M. machine and for milling operations also for checking and control

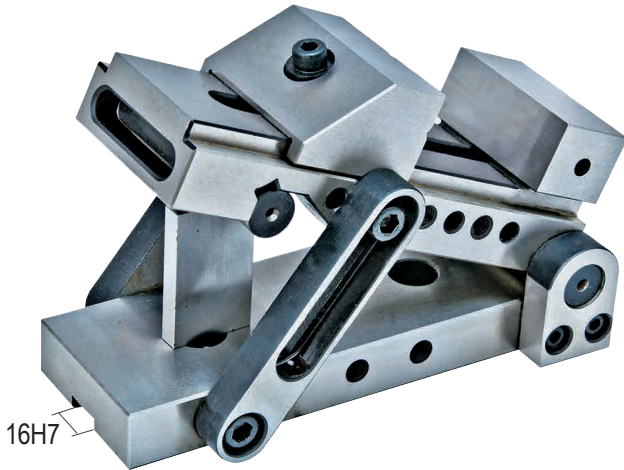

Dotazione standard: 2 chiavi di servizio Art. 376
 Standard equipment: 2 wrenches Art. 376

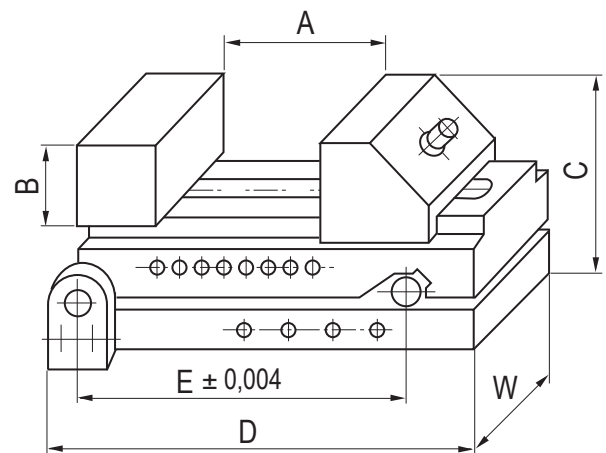

Tipo (grandezza) morsa / Vise type (size)	1	2	3	
Apertura massima / Maximum spread	A	100	150	214
Art. 668 Morse di precisione in acciaio inox Stainless steel precision vises	W	32	32	36
	B	30	35	40
	C	95	100	110
	D	170	226	300
	E	11	11	13,5
	F	9	9	9
	G	34	34	34
	H	50	70	70
	kg	4	5	6
	Cod.	1.66.81000	1.66.82000	1.66.83000

- Costruita in acciaio inox. Durezza HRC50-55
 Parallelismo e ortogonalità 0,005-0,008. Alta resistenza alla corrosione.
 Ideali per operazioni di controllo e elettroerosione
- Made of high quality stainless steel. Hardness HRC50-55.
 Parallelism and squareness of 0,005-0,008 mm. High corrosion-resistance.
 Best for measurement, inspection, EDM and wire-cutting machining.

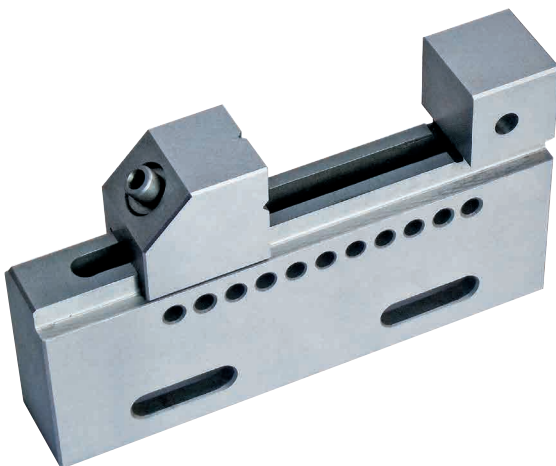

Dotazione standard: 1 chiave di servizio Art. 376
 Standard equipment: 1 wrench Art. 376

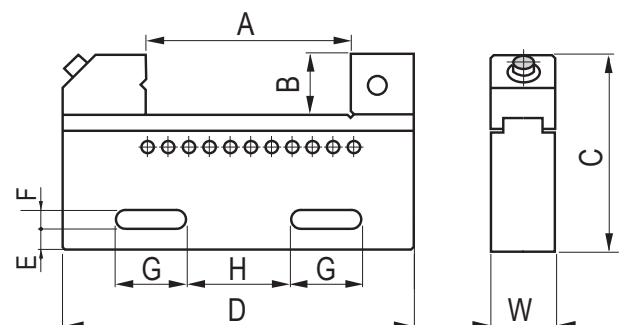

Diagrammi di serraggio / Clamping diagrams

OK Series

Diagrammi di serraggio meccanico con chiave dinamometrica

Mechanical clamping diagrams with torque wrench

Art. 666 / 666S

Morse tipo
Vises type

2

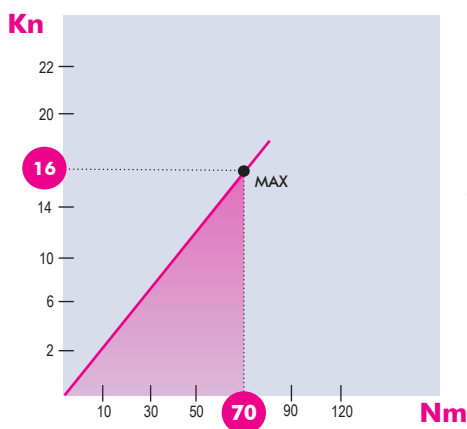

Art. 357

Morse tipo
Vises type

3

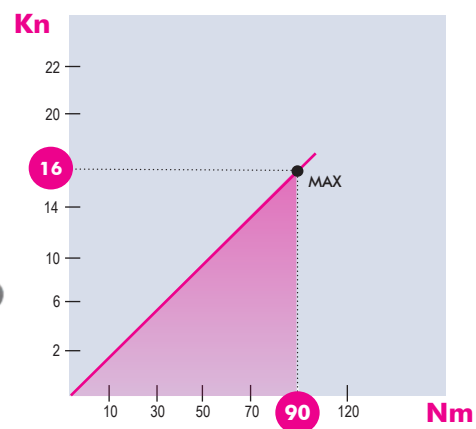

Morse tipo
Vises type

4-5-6-7

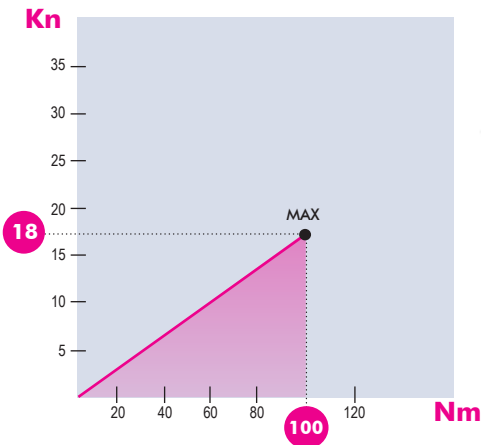

Art. 357

Morse tipo
Vises type

8

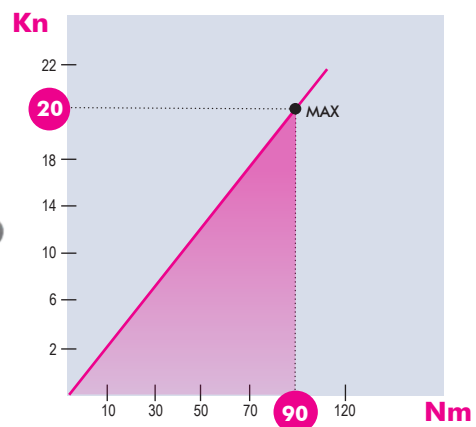

NB: Alcuni fattori, come la lubrificazione, lo staffaggio, gli attriti ed altro, possono modificare i valori indicati fino a $\pm 10\%$. Per un corretto utilizzo non superare i valori indicati nel grafico
 Some factor as lubrication, clamping on the machine table, frictions and more can modify above values within a $\pm 10\%$ range. For optimum operation do not exceed chart values.