

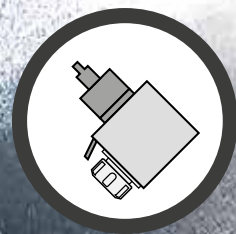

**GERARDI**

- DIN5480
- DIN5482
- BARUFFALDI
- DIN1809



4

*Choose the right model  
for your Machinings!*

## **VDI DRIVEN TOOLS**

**Portautensili motorizzati / Driven Tools**

# INDICE - INDEX

## VDI - DRIVEN TOOLS

pages

### DIN5480

**ASSIALE PORTA PINZA**  
AXIAL COLLET CHUCK

**ASSIALE PORTA FRESA**  
AXIAL SHELL END MILLING CUTTER

**ASSIALE PORTA WELDON**  
AXIAL WELDON CHUCK

**RADIALE PORTA PINZA**  
RADIAL COLLET CHUCK

**RADIALE PORTA FRESA**  
RADIAL SHELL END MILLING CUTTER

**RADIALE PORTA WELDON**  
RADIAL WELDON CHUCK

**ARRETRATO PORTA PINZA**  
REAR OFFSET COLLET CHUCK

**DOPPIO RADIALE PORTA PINZA**  
DOUBLE RADIAL COLLET CHUCK

**DISASSATO PORTAPINZA**  
OFFSET AXIS COLLET CHUCK

**DISASSATO PORTA FRESA**  
OFFSET AXIS SHELL END MILLING CUTTER

**ORIENTABILE ±90°**  
ADJUSTABLE ±90°

from 4.11  
to 4.20

### DIN5482

**ASSIALE PORTA PINZA**  
AXIAL COLLET CHUCK

**ASSIALE PORTA FRESA**  
AXIAL SHELL END MILLING CUTTER

**RADIALE PORTA PINZA**  
RADIAL COLLET CHUCK

**RADIALE PORTA FRESA**  
RADIAL SHELL END MILLING CUTTER

**ARRETRATO PORTA PINZA**  
REAR OFFSET COLLET CHUCK

**ARRETRATO PORTA FRESA**  
REAR OFFSET SHELL END MILLING CUTTER

**ORIENTABILE ±90°**  
ADJUSTABLE ±90°

from 4.21  
to 4.28

4

# INDICE - INDEX

## VDI - DRIVEN TOOLS

pages

<b>BARUFFALDI</b>	
<b>ASSIALE PORTA PINZA</b> AXIAL COLLET CHUCK	from 4.29 to 4.38
<b>ASSIALE PORTA FRESA</b> AXIAL SHELL END MILLING CUTTER	
<b>RADIALE PORTA PINZA</b> RADIAL COLLET CHUCK	
<b>RADIALE PORTA FRESA</b> RADIAL SHELL END MILLING CUTTER	
<b>ARRETRATO PORTA PINZA</b> REAR OFFSET COLLET CHUCK	
<b>ARRETRATO PORTA FRESA</b> REAR OFFSET SHELL END MILLING CUTTER	
<b>RADIALE DOPPIO PORTA PINZA</b> DOUBLE RADIAL COLLET CHUCK	
<b>ORIENTABILE ±90°</b> ADJUSTABLE ±90°	
<b>DIN1809</b>	
<b>ASSIALE PORTA PINZA</b> AXIAL COLLET CHUCK	from 4.39 to 4.44
<b>RADIALE PORTA PINZA</b> RADIAL COLLET CHUCK	
<b>ARRETRATO PORTA PINZA</b> REAR OFFSET COLLET CHUCK	
<b>ORIENTABILE ±90°</b> ADJUSTABLE ±90°	





PIÙ SEMPLICE / PIÙ INFO / PIÙ PRODOTTI - EASIER / MORE INFO / MORE PRODUCTS

TROVA IL TUO PRODOTTO IN POCHI CLICK - FIND YOUR PRODUCT IN FEW CLICKS



by category



by code



by description



by configurator

### Un nuovo modo facile e veloce per ordinare la tua attrezzatura Gerardi

Il nuovo Gerardi estore offre la possibilità di visualizzare e ordinare qualsiasi articolo Gerardi appartenente alle categorie Workholding o Tooling presente sui nostri listini in modo semplice, veloce e completo. Da ora puoi ordinare la morsa, la testa angolare o il motorizzato che ti interessa direttamente on-line dal nostro estore senza costi aggiuntivi.

### A new quick and easy way to order your equipment branded Gerardi.

The new Gerardi estore offers the ability to view and order any item available on our Workholding and Tooling catalogues with the easiest, fastest and comprehensive way. You can now order the vise, angle head or driven tool of your interest directly online from our store without any additional cost.

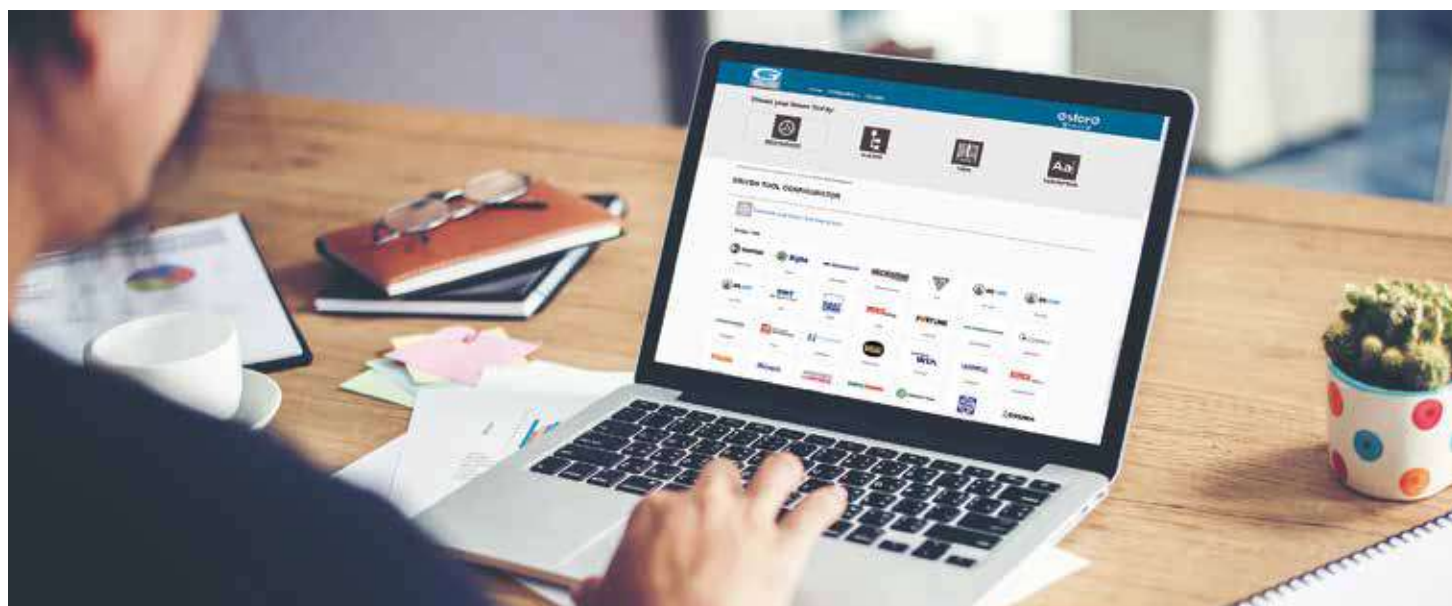

WINDOWS / IOS









ANDROID / IPHONE

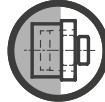
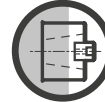
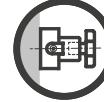

## SIMBOLI TIPOLOGIE MOTORIZZATI DRIVEN TOOLS DESIGN LOGOS

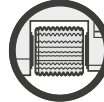
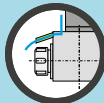
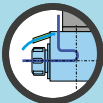
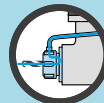
							
<b>Assiale</b> Axial	<b>Assiale doppio</b> Double Axial	<b>Disassato</b> Offset Axis	<b>Disassato Doppio</b> Double Offset Axis	<b>Radiale</b> Radial	<b>Radiale Doppio</b> Double Radial	<b>Radiale 4 Uscite</b> Radial 4 Outputs	<b>Radiale 8 Uscite</b> Radial 8 Outputs
							
<b>Radiale Rovesciato</b> Radial Upside Down	<b>Arretrato</b> Rear Offset	<b>Arretrato Doppio</b> Double Rear Offset	<b>Orientabile ±90°</b> Adjustable ±90°	<b>Portacreatore</b> Driven Gear Hobber			

## SIMBOLOGIA DATI TECNICI TECHNICAL DATA LOGOS

<b>USCITA</b> OUTPUT						
	<b>Uscita HSK</b> HSK output	<b>Uscita ISO</b> ISO output	<b>Uscita portafresa</b> Shell mill holder output	<b>Uscita WELDON</b> WELDON output	<b>Uscita CAPTO</b> CAPTO output	<b>Portacreatore</b> Driven Gear Hobber
<b>PASSAGGIO REFRIGERANTE</b> COOLANT						
				<b>Refrigerante Esterno</b> External Coolant	<b>Refrigerante Interno</b> Internal Coolant	<b>Refrigerante Interno</b> Internal Coolant
					<b>20/25/80</b> 100bar	<b>ReCool NUT</b>
<b>USCITA</b> OUTPUT						
			<b>Rapporto</b> Ratio	<b>Rotazione uguale al mandrino</b> Rotation same as machine spindle	<b>Rotazione opposta al mandrino</b> Rotation opposite as machine spindle	<b>Rotaz. uguale ed opposta al mandrino</b> Rotation same & opposite as machine spindle

# Portautensili Motorizzati / Driven Tools

# VDI



Velocità / High-speed  
**Max 24.000 Rpm**



Internal coolant  
fino a / Up to  
**100 Bar**

## Portautensili Motorizzati per torni CNC

### Driven Tools for CNC lathes

#### USCITE MULTIPLE MULTIPLE OUTPUTS

Tutti i motorizzati, ad esclusione di quelli ad angolo variabile, possono essere forniti con doppia pinza contrapposta anche di pari grandezza. Sono stati realizzati per i modelli di tornio più recenti anche motorizzati assiali con doppia / tripla uscita frontale e radiali doppia uscita frontale.

All the driven tools, with the exception of those with adjustable angle, can be supplied with double or multiple output even of the same dimension. Multiple outputs can be opposite or with the same direction.

#### ALTA VELOCITÀ RATIO 1:4 HIGH SPEED RATIO 1:4

(Opzione di moltiplica del numero di giri dalla torretta del tornio da 2 a 4 volte). Su richiesta, quasi tutti i modelli di motorizzati sono fornibili con velocità di rotazione fino a 24.000 Rpm. Questa soluzione permette di adeguare il numero di giri della torretta alle velocità di taglio delle nuove tipologie di utensili in commercio. Il sistema epicicloidale (interno) consente di mantenere inalterate le dimensioni di ingombro dei vari modelli, senza quindi penalizzare in alcun modo la funzionalità della macchina.

**N.B: I motorizzati standard con rapporto 1:1 hanno regime di rotazione Max. 6.000 Rpm**

All the driven tools types are available with speed until 24.000 Rpm. There is also the possibility of speed increaser from 2 to 4 times thus adapting the Rpm of the turret drive to the speed of today's cutting tools. The epicyclic speed increaser system (a system of satellite gears) is self contained in the standard head overall dimensions and guarantees the same standards of quality and reliability.

**Attention: The standard rotary tools with 1:1 ratio have a Max Speed of 6.000Rpm**

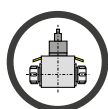

**Radiale Doppio**  
Double Radial



#### Trattamento Corpo Main Body Treated

Trattamento protettivo anti-ossidante del corpo  
Specially treated corrosion resistant steel body



#### Maschiatura Tapping

Per le operazioni di maschiatura, tutti i nostri motorizzati possono utilizzare pinze compensate ET-1 perfettamente intercambiabili con le normali pinze secondo norma DIN 6499. Esse consentono una compensazione assiale da 7 a 13 mm a seconda della grandezza per recuperare eventuali errori di avanzamento e per l'inversione della rotazione.

For tapping operations all driven tools can be equipped with axially compensated collets ET-1 interchangeable with the standard ER collets according to the international standard DIN 6499. They allow the tap an axial compensation from 7 to 13 mm according to their size in order to compensate any feed error and the inversion of the rotation of direction.



#### Cuscinetti Ball Bearings

Cuscinetti di precisione a contatto obliquo, precaricati e lubrificati con grasso a vita.

Preloaded angular contact ball bearings precision and long life lubrication.



#### Ingranaggi Gleason Gleason Spiral bevel gears

Coppia conica di ingranaggi spirodali Gleason con evolvente rettificato ottimizzato

Gleason spiral bevel gears with completely ground involute form

I portautensili motorizzati per centri di tornitura a controllo numerico consentono di eseguire lavorazioni di fresatura, foratura e maschiatura sul tornio stesso e senza ulteriori piazzamenti. Anche in questo caso Gerardi propone un'ampia gamma di modelli, adatti ad attrezzare i torni e le torrette motorizzate dei maggiori costruttori di torni a livello mondiale con un rapporto qualità/prezzo insuperabile. I portautensili motorizzati VDI 69880 sono costituiti da un albero dentato che per il montaggio viene inserito nella sede sulla faccia della torretta accoppiandosi perfettamente. Stringendo l'apposita vite di bloccaggio situata sulla faccia della torretta il motorizzato resta saldamente in posizione garantendo un'ottima rigidità durante le lavorazioni.

Driven tools for CNC turning centres allows milling, drilling and tapping operations on the lathes without additional parts handling. Also in this case Gerardi can supply a wide range of types in order to equip the CNC lathes and turrets of the most popular builders on the market with an unbeatable price/quality ratio. VDI 69880 Driven Tools consists of a toothed shaft that is inserted into the housing on the turret face for assembly, perfectly matching. By tightening the clamping screw located on the turret face, the motorised tool holder remains firmly in position, ensuring optimum rigidity during machining.

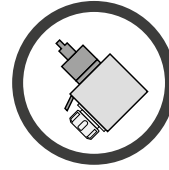

SCAN IT TO SEE



THE WEB PAGE



*Scegli il modello più adatto alla tua lavorazione!*

*Choose the right model to have the best machining!*

**Attacco VDI**  
VDI attachment

Prese di Moto - Couplings

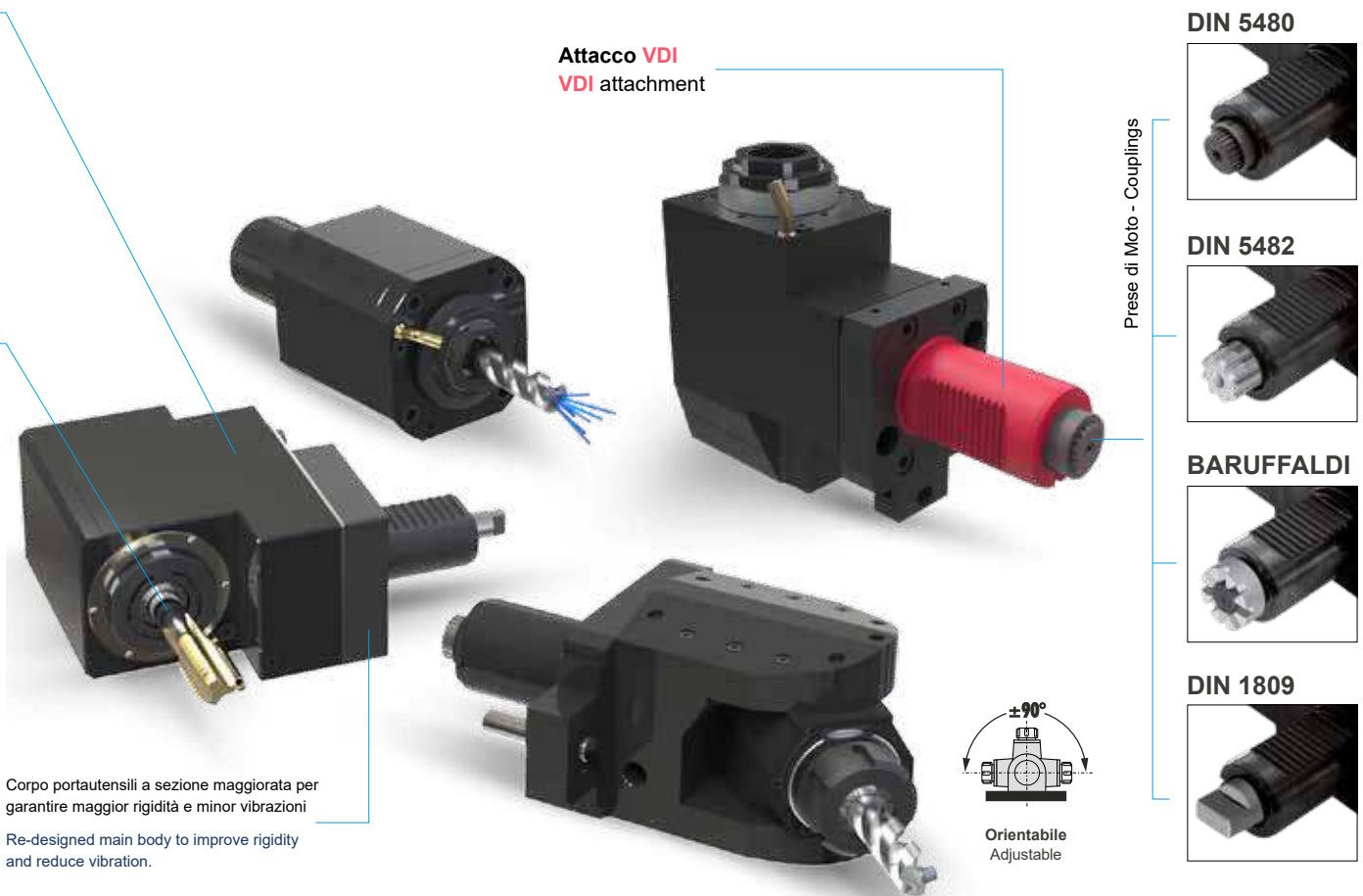

**DIN 5480**



**DIN 5482**



**BARUFFALDI**



**DIN 1809**



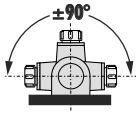

**Orientabile**  
Adjustable

Corpo portautensili a sezione maggiorata per garantire maggior rigidità e minor vibrazioni  
Re-designed main body to improve rigidity and reduce vibration.

## PASSAGGIO REFRIGERANTE - COOLANT TYPES:

 <p><b>Esterno</b> External</p> <ul style="list-style-type: none"> <li>» Mandrino Macchina</li> <li>» Corpo Motorizzato</li> <li>» Ugello</li> <li>» Machine Spindle</li> <li>» Driven Tool Body</li> <li>» Coolant Pipe</li> </ul>	 <p><b>Interno</b> Internal</p> <ul style="list-style-type: none"> <li>» Mandrino Macchina</li> <li>» Corpo Motorizzato</li> <li>» Distributore</li> <li>» Utensile</li> <li>» Machine Spindle</li> <li>» Driven Tool Body</li> <li>» Rotating Distributor</li> <li>» Tool</li> </ul>	 <p><b>Re-Cool Nut</b> Ghiera Re-Cool</p> <ul style="list-style-type: none"> <li>» Mandrino Macchina</li> <li>» Corpo Motorizzato</li> <li>» Ghiera Re-Cool</li> <li>» Utensile</li> <li>» Machine Spindle</li> <li>» Driven Tool Body</li> <li>» Re-Cool Nut</li> <li>» Tool</li> </ul>
---	--	---

## DENOMINAZIONE UTENSILE TOOL DESIGNATION

### Montaggio TANGENZIALE - OD Mounting

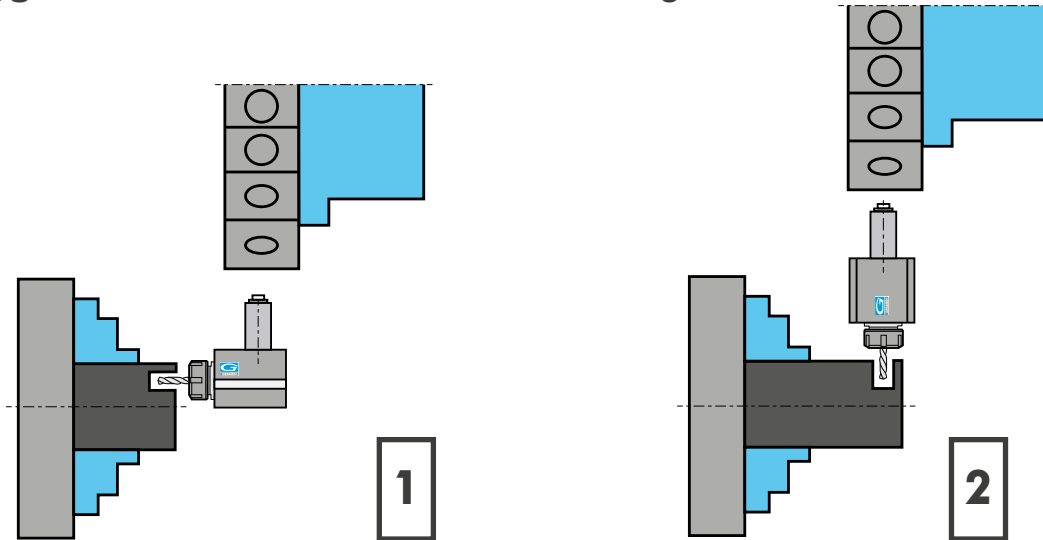

**1** Motorizzato RADIALE per lavorazioni assiali  
RADIAL driven tool for axial machining

**2** Motorizzato ASSIALE per lavorazioni radiali  
AXIAL driven tool heads for radial machining

### Montaggio FRONTALE - FACE Mounting

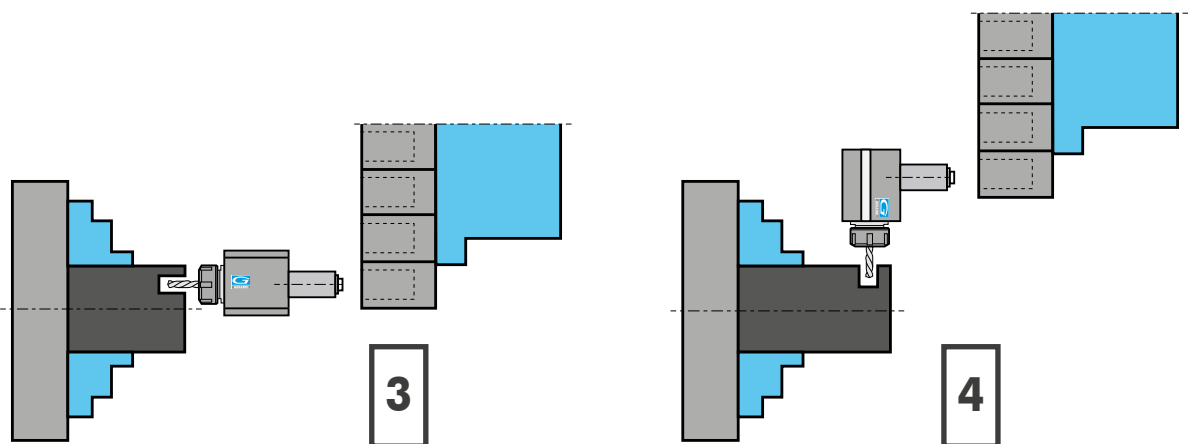

**3** Motorizzato ASSIALE per lavorazioni assiali  
AXIAL driven tool for axial machining

**4** Motorizzato RADIALE per lavorazioni radiali  
RADIAL driven tool heads for radial machining



# MOTORIZZATI RADIALI PER LAVORAZIONI ASSIALI

## RADIAL DRIVEN TOOLS FOR AXIAL MACHINING

### Montaggio TANGENZIALE - OD Mounting

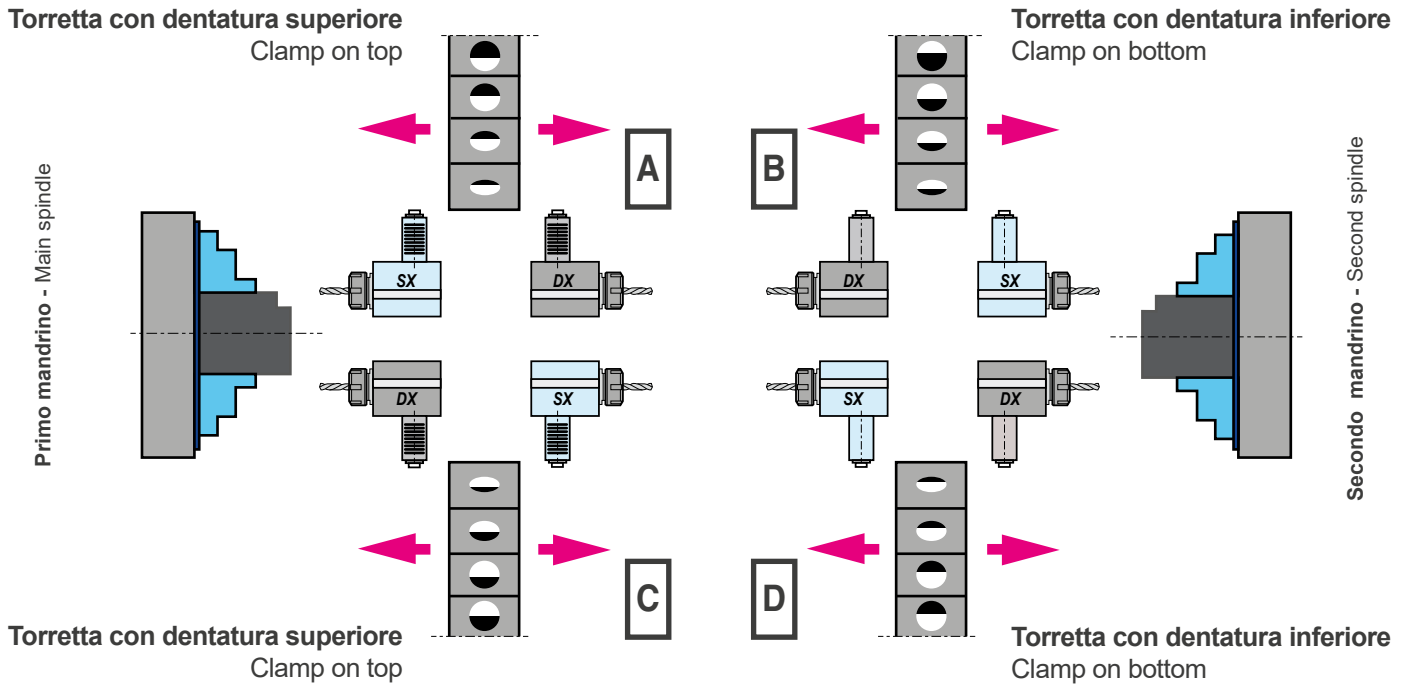

# MOTORIZZATI RADIALI PER LAVORAZIONI RADIALI

## RADIAL DRIVEN TOOLS FOR RADIAL MACHINING

### Montaggio FRONTALE - FACE Mounting

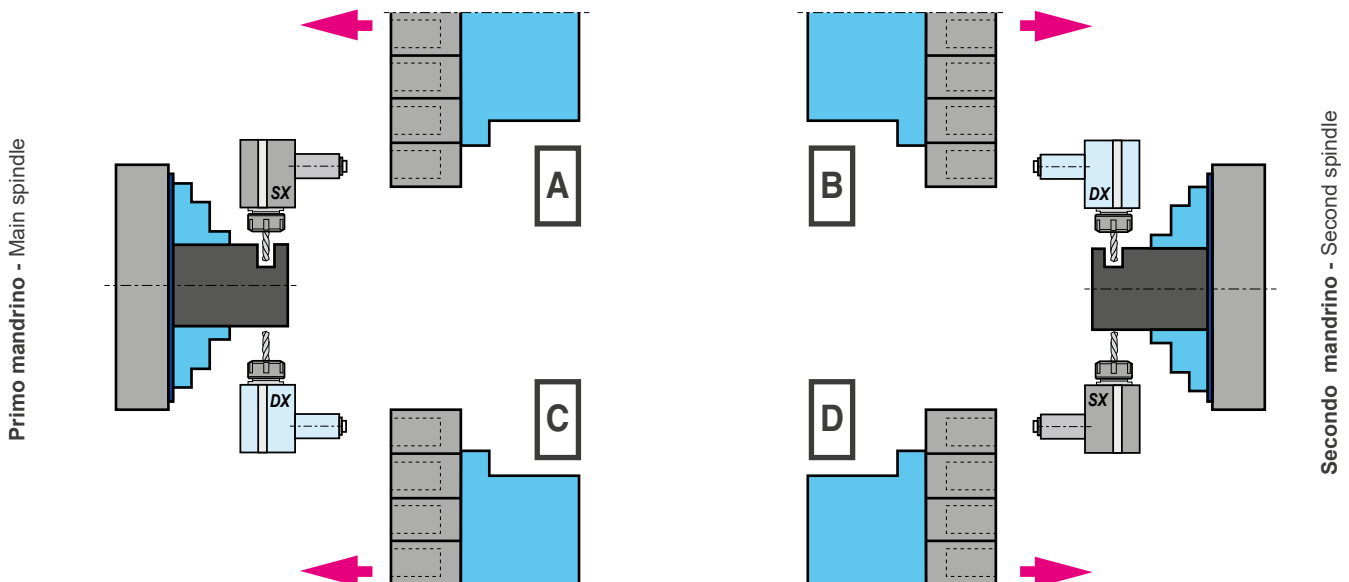



**HIGH PERF.**

**NEW  
2024**

# In arrivo Motorizzati Potenziati! Upgraded Driven Tools are coming!

## HIGH PERFORMANCE

**Elevata coppia e 12.000 Rpm per lavorazioni a secco!**  
High torque and 12.000 Rpm for dry running!

**Modelli Biglia già disponibili a catalogo. Prossimamente DMG MORI!**  
Biglia models already available in the catalogue. Coming soon DMG MORI!



### MASSIME PRESTAZIONI E PROGETTAZIONE OTTIMIZZATA

Maximum Performance and Optimised Design

- Progettazione ottimizzata nella struttura e nei cuscinetti
- Migliori performance in fresatura e foratura
- Albero principale esente da usura
- Optimized design in the structure and bearings
- Better performance in milling and drilling
- Wear-free main shaft



### EFFICIENZA TERMICA E MANUTENZIONE SEMPLIFICATA

Thermal efficiency and simplified maintenance

- Ridotto incremento delle temperature
- Tenuta meccanica senza guarnizione
- Montaggio smontaggio semplificati
- Intervalli di manutenzione ridotti
- Reduced increase in temperatures
- Mechanical seal without gasket
- Simplified assembly and disassembly
- Reduced maintenance intervals



### POSSIBILITÀ DI LAVORARE A SECCO

Dry running available

- Possibilità di lavorare a secco ad alte velocità (ma con valori ridotti del 70%)
- Continuo miglioramento della tecnologia di tenuta
- Possibility of dry running at high speeds (but with values reduced by 70%)
- Continuous improvement of sealing technology



### CHIAVE DI BLOCCAGGIO CON SISTEMA "SENZA MANI"

'Hands-free' locking wrench

- La chiave di bloccaggio dell'albero portapinzza rimane fissa liberando una mano per un migliore serraggio dell'utensile
- Ridotto il tempo operativo di attrezzaggio
- The collet holder shaft locking key remains fixed, freeing one hand for better tightening of the tool
- Reduced operating time when tooling up the machine.

Contatta il tuo Agente di zona - Ask to your area Distributor

**PROSSIMAMENTE NUOVI MODELLI!**  
**NEW MODELS COMING SOON!**

TORRETTA TIPO / TURRET TYPE  
DIN69880 (VDI STANDARD)



DIN 5480



DIN 5482

BARUFFALDI

DIN 1809

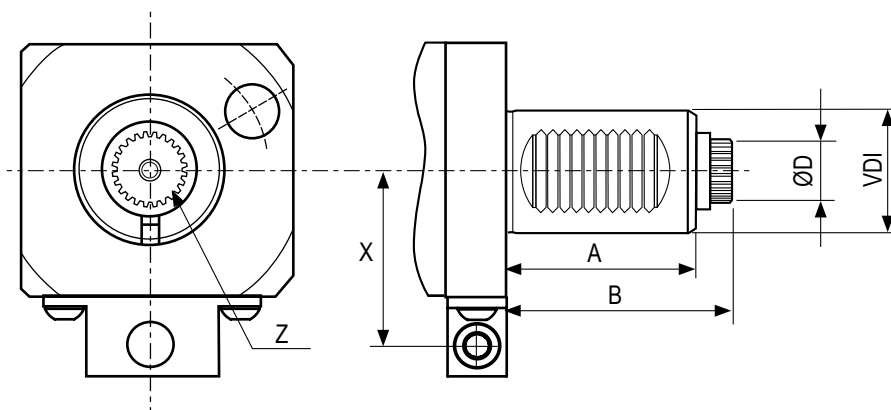

VDI	A	B	ØD	Z (N° denti - Teeth)	X
20	35	51	10,8	12	-
25	48	57	13,8	16	40
30	55	67	15,8	18	48
40	63	75	19,8	24	56
50	78	93	23,8	18	64



**DOTAZIONE STANDARD**  
STANDARD EQUIPMENT

Chiave bloccaggio albero Art.179CH /  
ugello refrigerazione Art.180 / vite bloccaggio ugello  
Art.179CH shaft lock wrench /  
cooling nozzle Art.180 / nozzle lock screws



**CAMBI RAPIDI MODULARI** Vedi pag. 7.12 - 7.15  
MODULAR QUICK CHANGE See page 7.12 - 7.15

Facile e veloce sistema modulare per il cambio rapido delle diverse  
tipologie di portautensili con la sede per pinza ER (DIN6499).  
Modular toolholder system for the fitting of toolholders in  
a spindle unit with ER collets (DIN6499) outputs.

MODELLI DI TORNIO COMPATIBILI  
COMPATIBLE LATHE TYPES

VDI 20 / VDI 30 / VDI 40 / VDI 50 / VDI 60



Vedi pagine compatibilità 5.10 / 5.13 - See compatibility pages 5.10 / 5.13

**VDI**  
DIN 5480

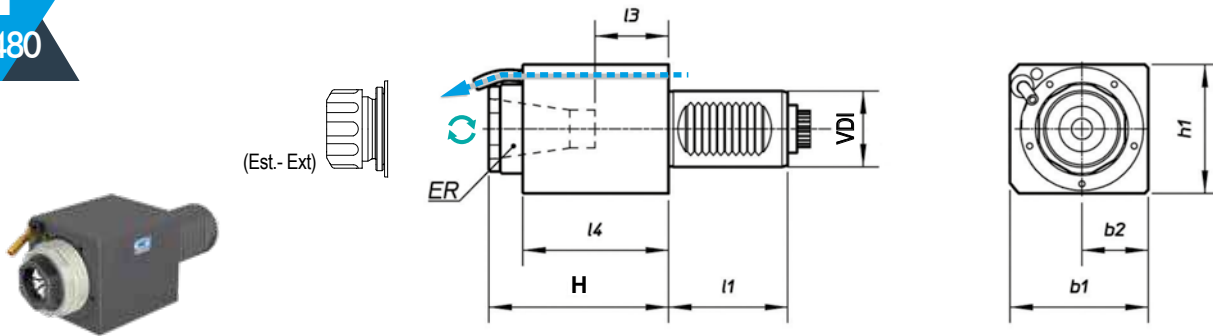

TIPO - TYPE  
**Assiale**  
Axial



USCITA - OUTPUT  
**Porta Pinza**  
Collet Chuck



REFRIGERANTE  
COOLANT  
**Esterno**  
External



RATIO  
**1:1**



ROTAZIONE - ROTATION  
**Uguale al mandrino**  
Same as machine spindle

Code	VDI	Output	Int Cool.	l1	H	l3	l4	b1	b2	h1	Nm	Rpm	kw
99.ST.8002	25	ER-25 - Ø1+16	NO	48	69	21	54,5	54	27	56	20	6.000	6
99.ST.8003	30	ER-25 - Ø1+16	NO	55	66	21	59	62	31	64	32	6.000	8
99.ST.8004	30	ER-25 - Ø1+16	NO	55	94	39	88	62	31	64	32	6.000	8
99.ST.8005	40	ER-32 - Ø2+20	NO	63	95	34	77	73	35	70	63	6.000	10
99.ST.8006	40	ER-32 - Ø2+20	NO	63	115	54	97	73	35	70	63	6.000	10
99.ST.8007	50	ER-40 - Ø3+30	NO	78	88	25	69	88	44	88	100	4.000	12
99.ST.8008	50	ER-40 - Ø3+30	NO	78	120	45	102	88	44	88	100	4.000	12
♦ 99.ST.80101	60	ER-40 - Ø3+26	NO	94	148,7	54	127	111	55,5	111	160	3.200	16

4

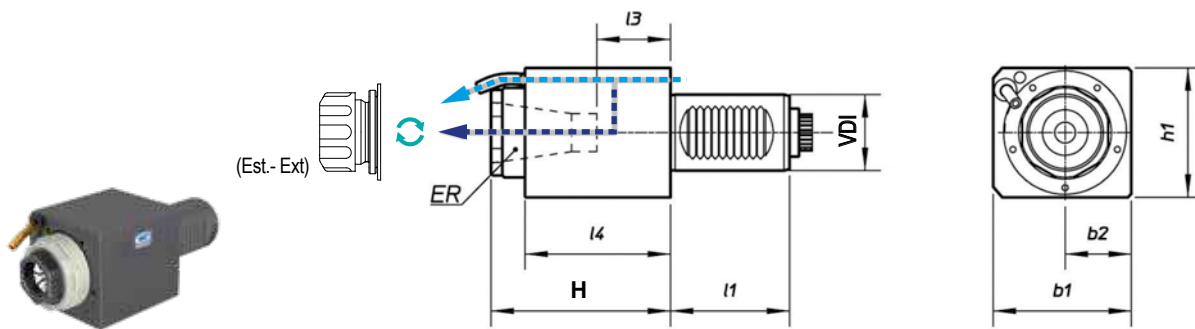

TIPO - TYPE  
**Assiale**  
Axial



USCITA - OUTPUT  
**Porta Pinza**  
Collet Chuck



REFRIGERANTE  
COOLANT  
**25 bar**



RATIO  
**1:1**



ROTAZIONE - ROTATION  
**Uguale al mandrino**  
Same as machine spindle

Code	VDI	Output	Int Cool.	l1	H	l3	l4	b1	b2	h1	Nm	Rpm	kw
99.ST.8010	25	ER-25 - Ø1+16	✓	48	89	41,5	74	54	27	56	32	6.000	6
99.ST.8011	30	ER-25 - Ø1+16	✓	55	66	21	59	62	31	64	32	6.000	8
99.ST.8012	30	ER-25 - Ø1+16	✓	55	94	39	88	62	31	64	32	6.000	8
99.ST.8013	40	ER-32 - Ø2+20	✓	63	95	34	77	73	35	70	63	6.000	10
99.ST.8014	40	ER-32 - Ø2+20	✓	63	115	54	97	73	35	70	63	6.000	10
99.ST.8015	50	ER-40 - Ø3+30	✓	78	120	45	102	88	44	88	100	4.000	12

MODELLI DI TORNIO COMPATIBILI  
 COMPATIBLE LATHE TYPES

**VDI 20 / VDI 30 / VDI 40 / VDI 50 / VDI 60**

Vedi pagine compatibilità 5.10 / 5.13 - See compatibility pages 5.10 / 5.13

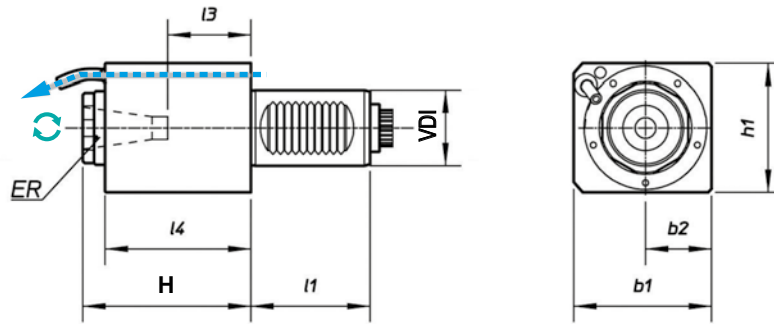
**VDI**  
**DIN 5480**

	TIPO - TYPE <b>Assiale</b> Axial		USCITA - OUTPUT <b>Porta Pinza</b> Collet Chuck		REFRIGERANTE COOLANT <b>Esterno</b> External		RATIO <b>1:4</b>		ROTAZIONE - ROTATION <b>Uguale al mandrino</b> Same as machine spindle
--	--	--	---	--	---	--	---------------------	--	--

Code	VDI	Output	Int Cool.	l1	H	l3	l4	b1	b2	h1	Nm	Rpm	kw
99.ST.8018	25	ER-16 - Ø1±10	NO	48	98,5	60,5	89,5	54	27	56	5	24.000	3
♦ 99.ST.8019	30	ER-16 - Ø1±10	NO	-	100	-	-	62	31	64	32	20.000	-
99.ST.8020	40	ER-20 - Ø1±13	NO	63	112,5	74,5	106	76	38	76	16	16.000	5

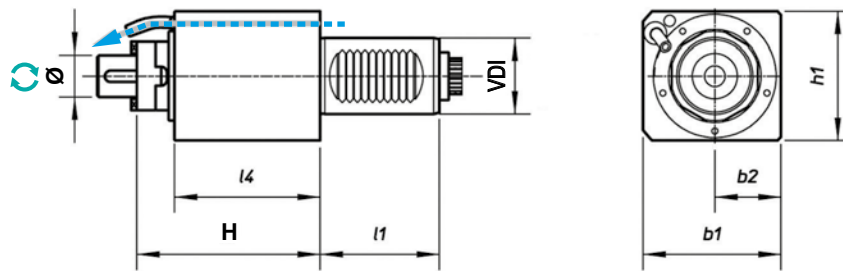

	TIPO - TYPE <b>Assiale</b> Axial		USCITA - OUTPUT <b>Porta Fresa</b> Shell End Milling Cutter		REFRIGERANTE COOLANT <b>Esterno</b> External		RATIO <b>1:1</b>		ROTAZIONE - ROTATION <b>Uguale al mandrino</b> Same as machine spindle
--	--	--	---	--	---	--	---------------------	--	--

Code	VDI	Output	Int Cool.	l1	H	l4	b1	b2	h1	Nm	Rpm	kw
99.ST.8024	30	Ø22	NO	55	112	88	62	31	64	32	6.000	8
99.ST.8025	40	Ø22	NO	63	102	77	73	35	70	63	6.000	10



MODELLI DI TORNIO COMPATIBILI  
COMPATIBLE LATHE TYPES

VDI 20 / VDI 30 / VDI 40 / VDI 50 / VDI 60



Vedi pagine compatibilità 5.10 / 5.13 - See compatibility pages 5.10 / 5.13

**VDI**  
DIN 5480

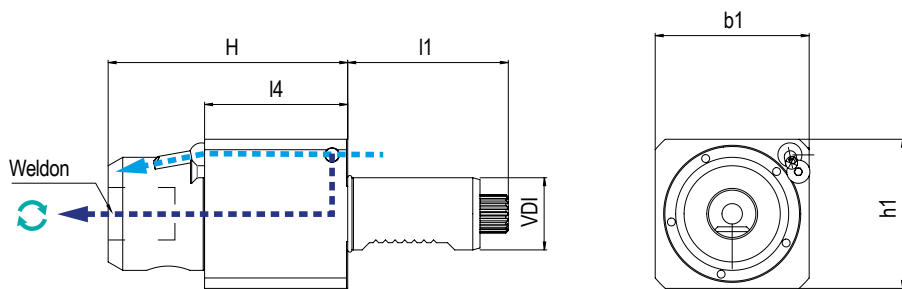

TIPO - TYPE  
**Assiale**  
Axial



USCITA - OUTPUT  
**Weldon**



REFRIGERANTE  
COOLANT  
**25 bar**



RATIO  
**1:1**



ROTAZIONE - ROTATION  
**Uguale al mandrino**  
Same as machine spindle

Code	VDI	Output	Int Cool.	I1	H	I4	b1	h1	Nm	Rpm	kw	
99.ST.80103	30	Weldon Ø20	NO	66,7	99,59	59,5	64	62	32	5.000	8	
99.ST.80104	30	Weldon Ø20	✓	66,7	99,59	59,5	64	62	32	5.000	8	
99.ST.80105	30	Weldon Ø16	NO	66,7	99,59	59,5	64	62	32	5.000	8	
99.ST.80106	30	Weldon Ø16	✓	66,7	99,59	59,5	64	62	32	5.000	8	



Vedi pagine compatibilità 5.10 / 5.13 - See compatibility pages 5.10 / 5.13

**VDI**  
**DIN 5480**

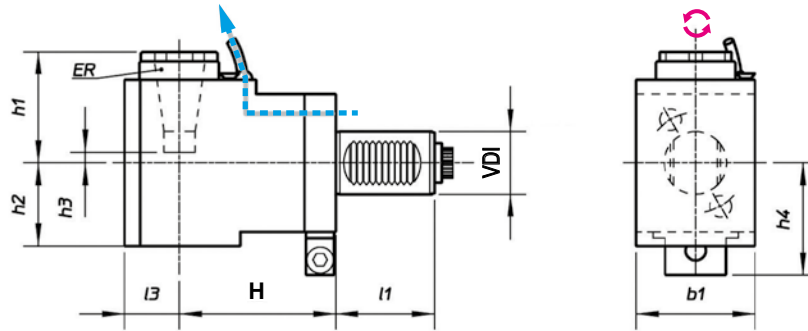

TIPO - TYPE

Radiale  
Radial



USCITA - OUTPUT

Porta Pinza  
Collet Chuck



REFRIGERANTE  
COOLANT

Esterno  
External



RATIO

1:1



ROTAZIONE - ROTATION

Opposto al mandrino  
Opposite to machine spindle

Code	VDI	Output	Int Cool.	l1	H	l3	b1	h1	h2	h3	h4	Nm	Rpm	kw
99.ST.8029	25	ER-25 - Ø1+16	NO	48	75	28	54	50,5	42	4	48	20	6.000	6
99.ST.8030	30	ER-25 - Ø1+16	NO	55	55	31	64	56	48	3	54	32	6.000	8
99.ST.8031	30	ER-25 - Ø1+16	NO	55	85	31	64	56	48	3	54	32	6.000	8
99.ST.8032	30	ER-25 - Ø1+16	NO	55	100	31	64	56	48	3	54	32	6.000	8
99.ST.8033	40	ER-32 - Ø2+20	NO	63	100	35	76	71	55	11	71	63	6.000	10
99.ST.8034	40	ER-32 - Ø2+20	NO	63	120	35	76	71	55	11	71	63	6.000	10
99.ST.8035	50	ER-40 - Ø3+30	NO	78	110	44	88	92	73	16	79	100	4.000	12

4

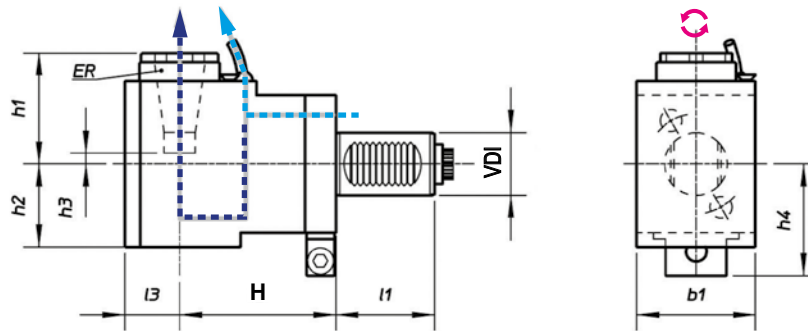

TIPO - TYPE

Radiale  
Radial



USCITA - OUTPUT

Porta Pinza  
Collet Chuck



REFRIGERANTE  
COOLANT

25 bar



RATIO

1:1



ROTAZIONE - ROTATION

Opposto al mandrino  
Opposite to machine spindle

Code	VDI	Output	Int Cool.	l1	H	l3	b1	h1	h2	h3	h4	Nm	Rpm	kw
99.ST.8037	25	ER-25 - Ø1+16	✓	48	75	28	54	60	61	4	48	20	6.000	6
99.ST.8038	30	ER-25 - Ø1+16	✓	55	55	31	64	56	60	2	54	32	6.000	8
99.ST.8039	30	ER-25 - Ø1+16	✓	55	85	31	64	56	60	2	54	32	6.000	8
99.ST.8040	30	ER-25 - Ø1+16	✓	55	100	31	64	56	60	2	54	32	6.000	8
99.ST.8041	40	ER-32 - Ø2+20	✓	63	100	35	76	71	62	11	71	63	6.000	10
99.ST.8042	40	ER-32 - Ø2+20	✓	63	120	35	76	71	73	11	71	63	6.000	10
99.ST.8043	50	ER-40 - Ø3+30	✓	78	110	44	88	92	73	16	79	100	4.000	12

MODELLI DI TORNIO COMPATIBILI  
COMPATIBLE LATHE TYPES

VDI 20 / VDI 30 / VDI 40 / VDI 50 / VDI 60



Vedi pagine compatibilità 5.10 / 5.13 - See compatibility pages 5.10 / 5.13

**VDI**  
DIN 5480

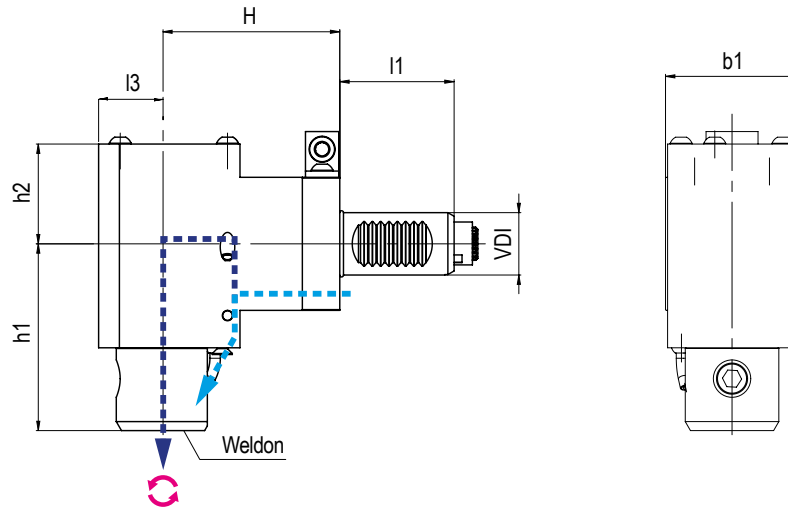

TIPO - TYPE  
**Radiale**  
Radial



USCITA - OUTPUT  
**Weldon**



REFRIGERANTE  
COOLANT  
**25 bar**



RATIO  
**1:1**



ROTAZIONE - ROTATION  
**Opposto al mandrino**  
Opposite to machine spindle

Code	VDI	Output	Int Cool.	I1	H	I3	b1	h1	h2	Nm	Rpm	kw	
99.ST.80107	30	Weldon Ø20	NO	55	85	31	64	89.8	48	60	10.000	10	
99.ST.80108	30	Weldon Ø20	✓	55	85	31	64	89.8	59.7	60	10.000	10	
99.ST.80109	30	Weldon Ø16	NO	55	85	31	64	89.9	48	60	10.000	10	
99.ST.80110	30	Weldon Ø16	✓	55	85	31	64	89.9	59.7	60	10.000	10	

4

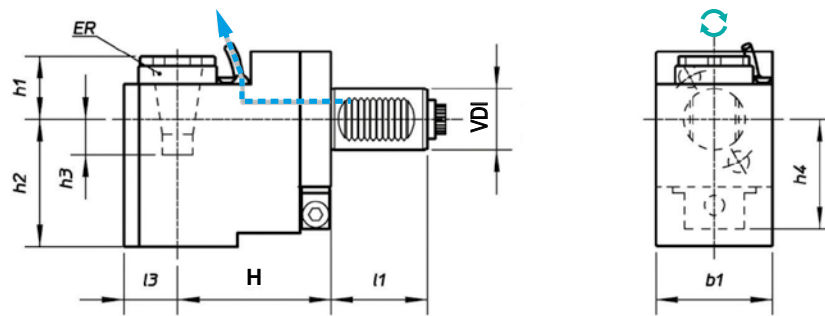

TIPO - TYPE  
**Arretrato**  
Rear Offset



USCITA - OUTPUT  
**Porta Pinza**  
Collet Chuck



REFRIGERANTE  
COOLANT  
**Esterno**  
External



RATIO  
**1:1**



ROTAZIONE - ROTATION  
**Uguale al mandrino**  
Same as machine spindle

Code	VDI	Output	Int Cool.	I1	H	I3	b1	h1	h2	h3	h4	Nm	Rpm	kw	
99.ST.8046	30	ER-25 - Ø1+16	NO	55	85	31	64	21	90	45	56	32	5.000	8	
99.ST.8047	30	ER-25 - Ø1+16	NO	55	100	31	64	21	90	45	56	32	5.000	8	
99.ST.8048	40	ER-32 - Ø2+20	NO	63	100	35	76	20	106	40	65.5	63	6.000	10	
99.ST.8049	50	ER-40 - Ø3+30	NO	78	110	44	88	31	123	44	73.5	100	4.000	12	

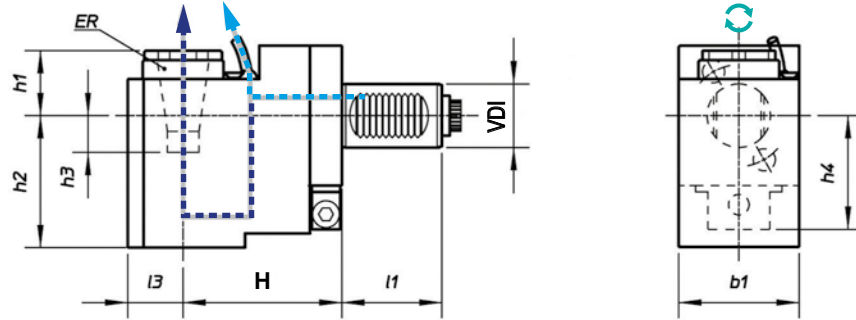

Vedi pagine compatibilità 5.10 / 5.13 - See compatibility pages 5.10 / 5.13

**VDI**  
**DIN 5480**

TIPO - TYPE

 Arretrato  
 Rear Offset

USCITA - OUTPUT

 Porta Pinza  
 Collet Chuck

 REFRIGERANTE  
 COOLANT

**25 bar**



RATIO

**1:1**

ROTAZIONE - ROTATION

 Uguale al mandrino  
 Same as machine spindle

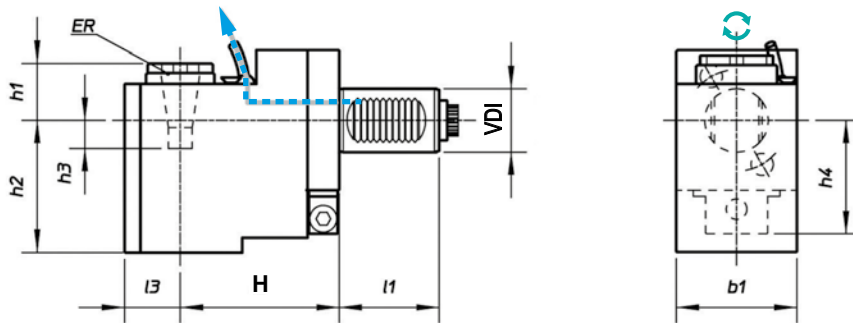
Code	VDI	Output	Int Cool.	l1	H	l3	b1	h1	h2	h3	h4	Nm	Rpm	kw
99.ST.8052	30	ER-25 - Ø1+16	✓	55	85	31	64	24	105,5	45,5	56	32	5.000	8
99.ST.8053	30	ER-25 - Ø1+16	✓	55	100	31	64	24	105,5	45,5	56	32	5.000	8
99.ST.8054	40	ER-32 - Ø2+20	✓	63	100	35	76	30	124	40	65,5	63	6.000	10
99.ST.8055	50	ER-40 - Ø3+30	✓	78	110	44	88	44	140,5	44	80,5	100	4.000	12



TIPO - TYPE

 Arretrato  
 Rear Offset

USCITA - OUTPUT

 Porta Pinza  
 Collet Chuck

 REFRIGERANTE  
 COOLANT

 Esterno  
 External

RATIO

**1:4**

ROTAZIONE - ROTATION

 Uguale al mandrino  
 Same as machine spindle

Code	VDI	Output	Int Cool.	l1	H	l3	b1	h1	h2	h3	h4	Nm	Rpm	kw
99.ST.8057	25	ER-16 - Ø1+10	NO	48	90	21	54	31	81	11	48	5	24.000	3
99.ST.8059	40	ER-20 - Ø1+13	NO	63	125	27	76	45	108	10	65,5	16	16.000	5

MODELLI DI TORNIO COMPATIBILI  
COMPATIBLE LATHE TYPES

VDI 20 / VDI 30 / VDI 40 / VDI 50 / VDI 60



Vedi pagine compatibilità 5.10 / 5.13 - See compatibility pages 5.10 / 5.13

**VDI**  
DIN 5480

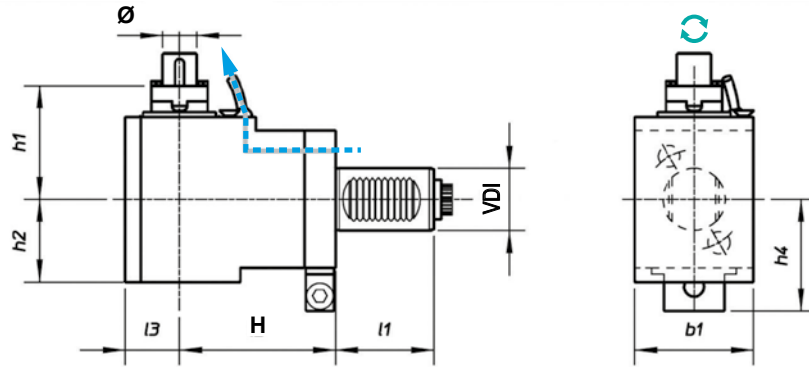

TIPO - TYPE  
**Radiale**  
Radial



USCITA - OUTPUT  
**Porta Fresa**  
Shell End Milling Cutter



REFRIGERANTE  
COOLANT  
**Esterno**  
External



RATIO  
**2:1**



ROTAZIONE - ROTATION  
**Uguale al mandrino**  
Same as machine spindle

Code	VDI	Output	Int Cool.	l1	H	l3	b1	h1	h2	h4	Nm	Rpm	kw
99.ST.8070	25	Ø16	NO	48	75	28	54	66	48	48	40	3.000	6
99.ST.8071	30	Ø22	NO	55	55	31	64	74	48	56	63	2.500	8
99.ST.8074	40	Ø22	NO	63	100	35	76	78	55	65,5	63	3.000	8

4

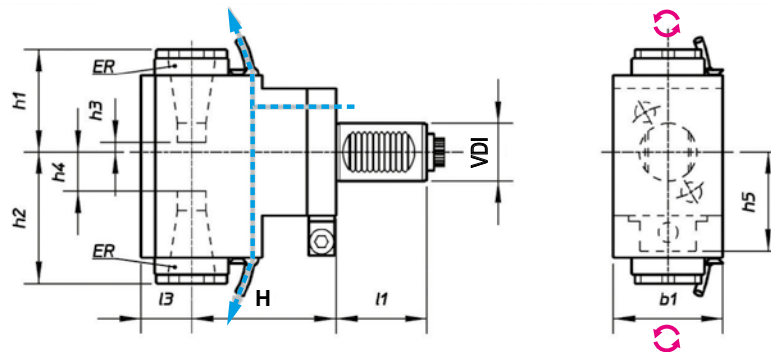

TIPO - TYPE  
**Radiale Doppio**  
Double Radial



USCITA - OUTPUT  
**Porta Pinza**  
Collet Chuck



REFRIGERANTE  
COOLANT  
**Esterno**  
External



RATIO  
**1:1**



ROTAZIONE - ROTATION  
**Opposto al mandrino**  
Opposite to machine spindle

Code	VDI	Output	Int Cool.	l1	H	l3	b1	h1	h2	h3	h4	h5	Nm	Rpm	kw
99.ST.8078	25	ER-20 - Ø1+13	NO	48	75	28	54	50,5	71,5	4	32	48	20	6.000	6
99.ST.8079	30	ER-25 - Ø1+16	NO	55	85	31	64	63	84	2,5	22,5	56	32	5.000	8
99.ST.8080	30	ER-25 - Ø1+16	NO	55	100	31	64	63	84	2,5	22,5	56	32	5.000	8
99.ST.8081	40	ER-32 - Ø2+20	NO	63	100	35	76	71	96	11	36,5	65,5	63	6.000	10
99.ST.8082	40	ER-32 - Ø2+20	NO	63	120	35	76	71	96	11	36,5	65,5	63	6.000	10



**MODELLI DI TORNIO COMPATIBILI**  
 COMPATIBLE LATHE TYPES

**VDI 20 / VDI 30 / VDI 40 / VDI 50 / VDI 60**

Vedi pagine compatibilità 5.10 / 5.13 - See compatibility pages 5.10 / 5.13

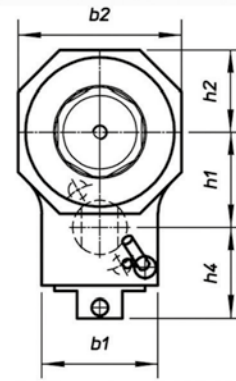
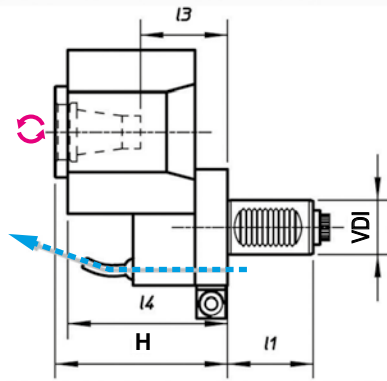
**VDI**  
**DIN 5480**

 TIPO - TYPE  
 Disassato  
 Offset Axis

 USCITA - OUTPUT  
 Porta Pinza  
 Collet Chuck

 REFRIGERANTE  
 COOLANT  
 Esterno  
 External

 RATIO  
**2:1**

 ROTAZIONE - ROTATION  
 Opposto al mandrino  
 Opposite to machine spindle

Code	VDI	Output	Int Cool.	l1	H	l4	b1	b2	h1	h2	h4	Nm	Rpm	kw
99.ST.8083	30	ER-25 - Ø1+16	NO	55	95	88	64	90	52,5	45	54	64	3.000	8
99.ST.80111	30	ER-32 - Ø2+20	NO	55	100,25	88	-	90	-	-	-	63	2.500	8
99.ST.80112	40	ER-32 - Ø2+20	NO	63	99	92	76	108	68,5	54	65,5	100	2.000	10

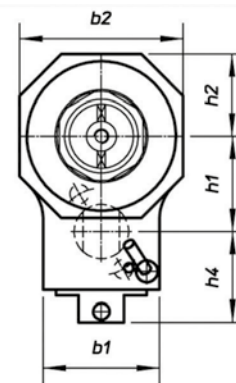
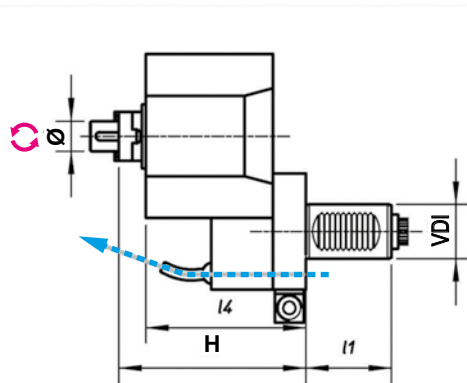
 TIPO - TYPE  
 Disassato  
 Offset Axis

 USCITA - OUTPUT  
 Porta Fresa  
 Shell End Milling Cutter

 REFRIGERANTE  
 COOLANT  
 Esterno  
 External

 RATIO  
**2:1**

 ROTAZIONE - ROTATION  
 Opposto al mandrino  
 Opposite to machine spindle

Code	VDI	Output	Int Cool.	l1	H	l4	b1	b2	h1	h2	h4	Nm	Rpm	kw
99.ST.8084	30	Ø22	NO	55	95	88	64	90	52,5	45	54	64	3.000	8
99.ST.8012A	40	Ø22	NO	63	117	92	76	108	68,5	54	65,5	100	2.000	10

MODELLI DI TORNIO COMPATIBILI  
COMPATIBLE LATHE TYPES

VDI 20 / VDI 30 / VDI 40 / VDI 50 / VDI 60



Vedi pagine compatibilità 5.10 / 5.13 - See compatibility pages 5.10 / 5.13

**VDI**  
DIN 5480

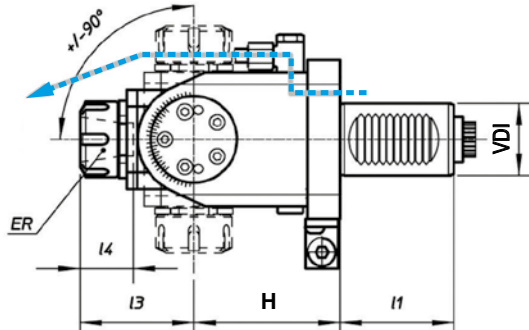
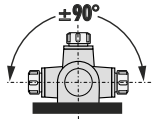

**SINISTRO - LEFT**  
(Standard)

**DESTRO - RIGHT**  
(Specify)

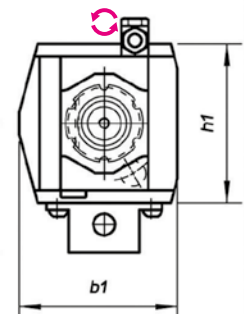
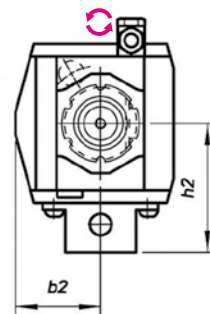

TIPO - TYPE  
**Orientabile**  
Adjustable  $\pm 90^\circ$



USCITA - OUTPUT  
**Porta Pinza**  
Collet Chuck



REFRIGERANTE  
COOLANT  
**Esterno**  
External



RATIO  
**1:1**



ROTAZIONE - ROTATION  
**Opposto al mandrino**  
Opposite to machine spindle

Code	VDI	Output	Int Cool.	l1	H	l3	l4	b1	b2	h1	h2	Nm	Rpm	kw
99.ST.80100	20	ER-16 - Ø1±10	NO	39,6	70	52	-	69,5	-	50	-	15	6.000	2
99.ST.8086	25	ER-16 - Ø1±10	NO	48	55	54	34,5	70,5	38	65	49,5	10	6.000	2
99.ST.8097	25	ER-20 - Ø1±13	NO	48	70	52	37	70	37	64	54	15	6.000	3
99.ST.8087	30	ER-20 - Ø1±13	NO	55	64	52	37	70	37	64	54	15	6.000	3
99.ST.8088	30	ER-20 - Ø1±13	NO	55	97	52	37	70	37	64	54	15	6.000	3
99.ST.8089	40	ER-25 - Ø1±16	NO	63	81	63	42	87	47	88	71	25	6.000	4
99.ST.8098	40	ER-25 - Ø1±16	NO	63	120	63	42	87	47	88	71	25	6.000	4
♦ 99.ST.8096	50	ER-32 - Ø2±20	NO	78	123	101	47	134	54	108	78	50	4.000	6

4

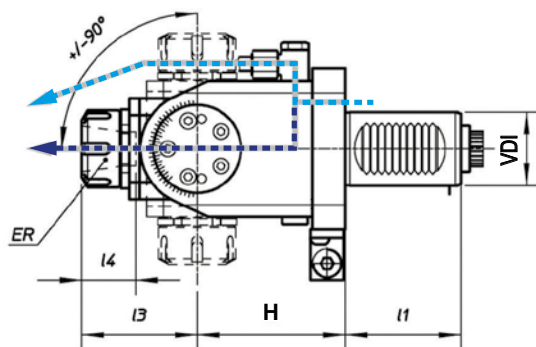
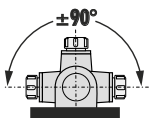

**SINISTRO - LEFT**  
(Standard)

**DESTRO - RIGHT**  
(Specify)

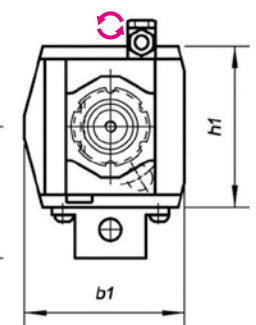
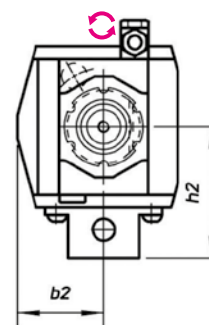

TIPO - TYPE  
**Orientabile**  
Adjustable  $\pm 90^\circ$



USCITA - OUTPUT  
**Porta Pinza**  
Collet Chuck



REFRIGERANTE  
COOLANT  
**25 bar**



RATIO  
**1:1**



ROTAZIONE - ROTATION  
**Opposto al mandrino**  
Opposite to machine spindle

Code	VDI	Output	Int Cool.	l1	H	l3	l4	b1	b2	h1	h2	h4	Nm	Rpm	kw
99.ST.8091	30	ER-20 - Ø1±13	✓	55	64	37	52	37	70	37	64	54	15	6.000	3
99.ST.8092	30	ER-20 - Ø1±13	✓	55	97	37	52	37	70	37	64	54	15	6.000	3
99.ST.8093	40	ER-25 - Ø1±16	✓	63	81	42	63	42	87	47	88	71	25	6.000	4



VDI 20 - 30 - 40 - 50 - 60

VDI  
DIN 5482

TORRETTA TIPO / TURRET TYPE  
DIN69880 (VDI STANDARD)



DIN 5482



DIN 5480

BARUFFALDI

DIN 1809

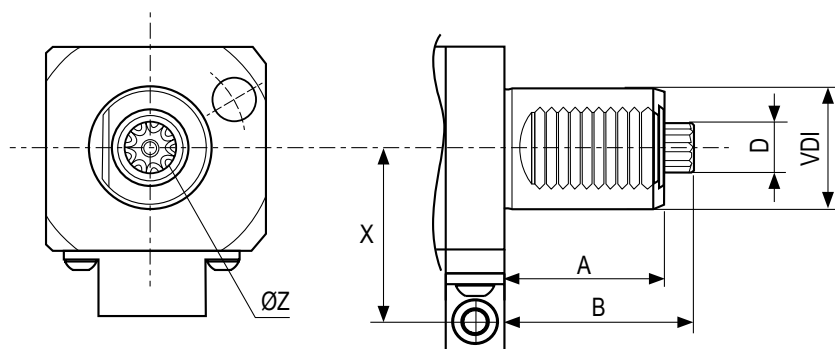

VDI	A	B	ØD	Z (N°denti - Teeth)	X
30	45	55	14,5	8	40
40	53	63	16,5	9	63
50	78	93	19,5	11	70
60	94	108	24,5	14	-



**DOTAZIONE STANDARD**  
STANDARD EQUIPMENT

Chiave bloccaggio albero Art.179CH /  
ugello refrigerazione Art.180 / vite bloccaggio ugello  
Art.179CH shaft lock wrench /  
cooling nozzle Art.180 / nozzle lock screws



**CAMBI RAPIDI MODULARI** Vedi pag. 7.12 - 7.15  
MODULAR QUICK CHANGE See page 7.12 - 7.15

Facile e veloce sistema modulare per il cambio rapido delle diverse  
tipologie di portautensili con la sede per pinza ER (DIN6499).  
Modular toolholder system for the fitting of toolholders in  
a spindle unit with ER collets (DIN6499) outputs.

MODELLI DI TORNIO COMPATIBILI  
COMPATIBLE LATHE TYPES

VDI 20 / VDI 30 / VDI 40 / VDI 50 / VDI 60



Vedi pagine compatibilità 5.10 / 5.13 - See compatibility pages 5.10 / 5.13

**VDI**  
DIN 5482

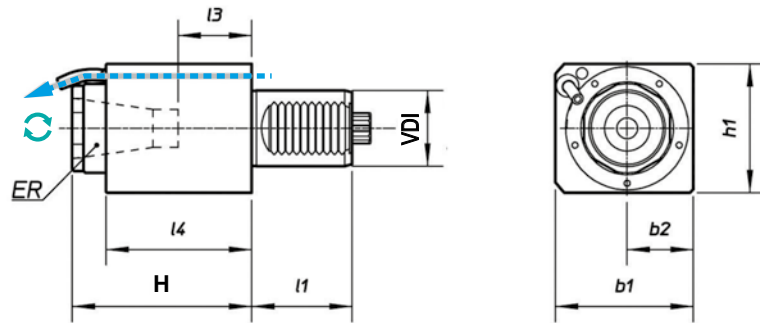

TIPO - TYPE  
Assiale  
Axial



USCITA - OUTPUT  
Porta Pinza  
Collet Chuck



REFRIGERANTE  
COOLANT  
Esterno  
External



RATIO  
1:1



ROTAZIONE - ROTATION  
Uguale al mandrino  
Same as machine spindle

Code	VDI	Output	Int Cool.	l1	H	l3	l4	b1	b2	h1	Nm	Rpm	kw	
99.ST.8201	30	ER-25 - Ø1+16	NO	45	94	39	88	62	31	64	32	6.000	8	
99.ST.8203	40	ER-32 - Ø2+20	NO	53	115	54	97	73	35	70	63	5.000	10	
99.ST.8205	50	ER-40 - Ø3+30	NO	78	150	75	142	88	44	88	100	4.000	12	
99.ST.8206	60	ER-50 - Ø7+34	NO	94	220	110	168	110	55	110	160	3.200	15	

4

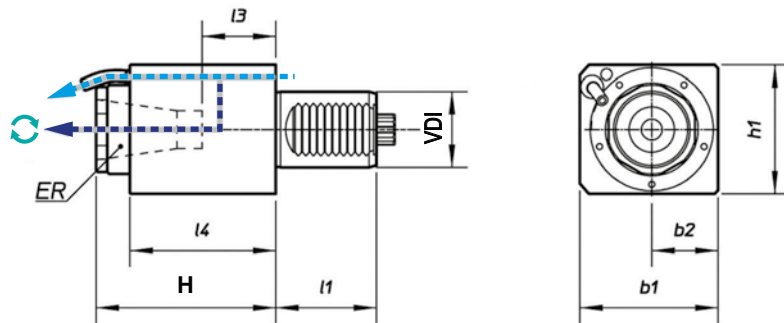

TIPO - TYPE  
Assiale  
Axial



USCITA - OUTPUT  
Porta Pinza  
Collet Chuck



REFRIGERANTE  
COOLANT  
25 bar



RATIO  
1:1



ROTAZIONE - ROTATION  
Uguale al mandrino  
Same as machine spindle

Code	VDI	Output	Int Cool.	l1	H	l3	l4	b1	b2	h1	Nm	Rpm	kw	
99.ST.8207	30	ER-25 - Ø1+16	✓	45	94	39	88	62	31	64	32	6.000	8	
99.ST.8208	40	ER-32 - Ø2+20	✓	53	115	54	97	73	35	70	63	5.000	10	
99.ST.8210	50	ER-40 - Ø3+30	✓	78	133	45	112	88	44	88	100	4.000	12	
99.ST.8211	60	ER-50 - Ø7+34	✓	94	228	110	168	110	55	110	160	3.200	15	

MODELLI DI TORNIO COMPATIBILI  
 COMPATIBLE LATHE TYPES

**VDI 20 / VDI 30 / VDI 40 / VDI 50 / VDI 60**

Vedi pagine compatibilità 5.10 / 5.13 - See compatibility pages 5.10 / 5.13

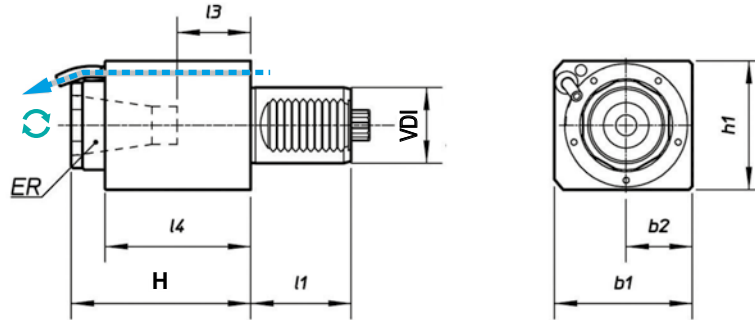
**VDI**  
**DIN 5482**

	TIPO - TYPE <b>Assiale</b> Axial		USCITA - OUTPUT <b>Porta Pinza</b> Collet Chuck		REFRIGERANTE COOLANT <b>Esterno</b> External		RATIO <b>1:4</b>		ROTAZIONE - ROTATION <b>Uguale al mandrino</b> Same as machine spindle
--	--	--	---	--	---	--	---------------------	--	--

Code	VDI	Output	Int Cool.	l1	H	l3	l4	b1	b2	h1	Nm	Rpm	kw
99.ST.8212	30	ER-16 - Ø1+10	NO	45	100	58	88	62	31	64	8	20.000	4
99.ST.8213	40	ER-20 - Ø1+13	NO	53	112,5	74,5	106	76	38	76	16	16.000	5
99.ST.8214	50	ER-20 - Ø1+13	NO	78	128,5	88,5	122	88	44	88	25	16.000	6

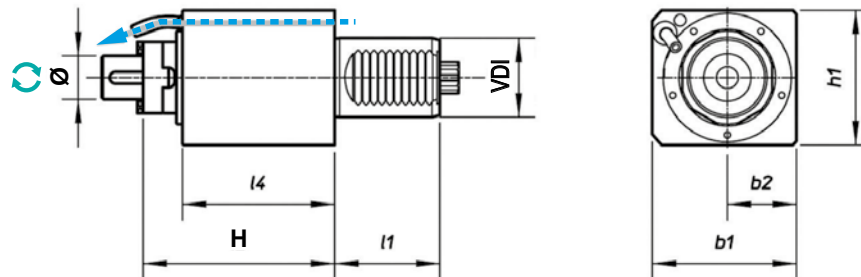

	TIPO - TYPE <b>Assiale</b> Axial		USCITA - OUTPUT <b>Porta Fresa</b> Shell End Milling Cutter		REFRIGERANTE COOLANT <b>Esterno</b> External		RATIO <b>1:1</b>		ROTAZIONE - ROTATION <b>Uguale al mandrino</b> Same as machine spindle
--	--	--	---	--	---	--	---------------------	--	--

Code	VDI	Output	Int Cool.	l1	H	l3	l4	b1	b2	h1	Nm	Rpm	kw
99.ST.8215	30	Ø22	NO	45	112		88	62	31	64	32	6.000	8



MODELLI DI TORNIO COMPATIBILI  
COMPATIBLE LATHE TYPES

VDI 20 / VDI 30 / VDI 40 / VDI 50 / VDI 60



Vedi pagine compatibilità 5.10 / 5.13 - See compatibility pages 5.10 / 5.13

VDI  
DIN 5482

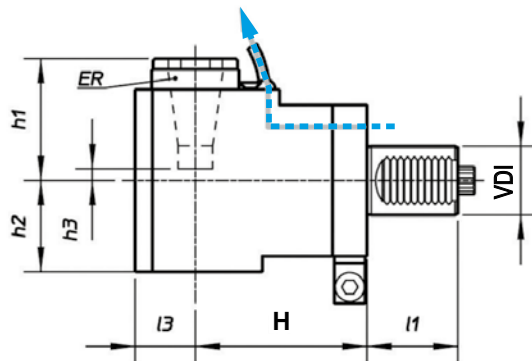

SINISTRO - LEFT  
(Standard)

DESTRO - RIGHT  
(Specify)

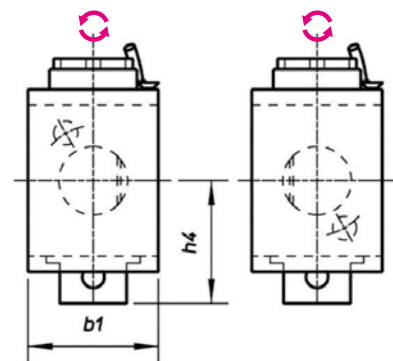

TIPO - TYPE  
Radiale  
Radial



USCITA - OUTPUT  
Porta Pinza  
Collet Chuck



REFRIGERANTE  
COOLANT  
Esterno  
External



RATIO  
1:1



ROTAZIONE - ROTATION  
Opposto al mandrino  
Opposite to machine spindle

Code	VDI	Output	Int Cool.	l1	H	l3	b1	h1	h2	h3	h4	Nm	Rpm	kw
99.ST.8217	30	ER-25 - Ø1+16	NO	45	55	31	64	56	48	3	52	32	6.000	8
99.ST.8220	40	ER-32 - Ø2+20	NO	53	100	35	76	71	55	11	71	63	5.000	10
99.ST.8221	50	ER-40 - Ø3+30	NO	78	110	44	88	92	62	17	80,5	100	4.000	12
99.ST.8222	60	ER-50 - Ø7+34	NO	94	130	55	110	149	102	39	103	160	3.200	15

4

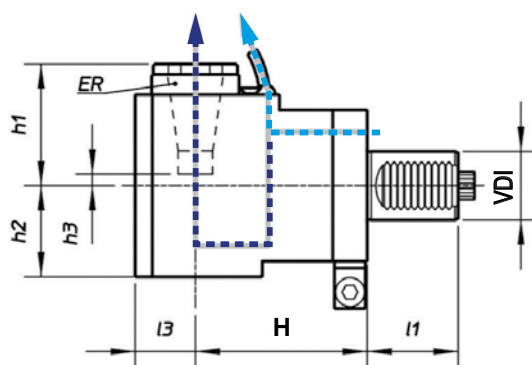

SINISTRO - LEFT  
(Standard)

DESTRO - RIGHT  
(Specify)

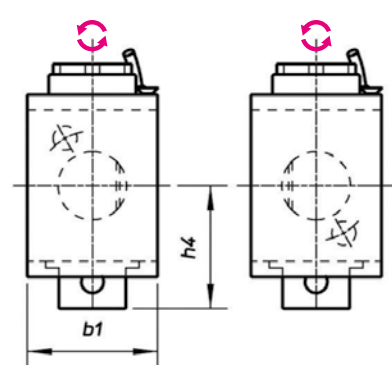

TIPO - TYPE  
Radiale  
Radial



USCITA - OUTPUT  
Porta Pinza  
Collet Chuck



REFRIGERANTE  
COOLANT  
25 bar



RATIO  
1:1



ROTAZIONE - ROTATION  
Opposto al mandrino  
Opposite to machine spindle

Code	VDI	Output	Int Cool.	l1	H	l3	b1	h1	h2	h3	h4	Nm	Rpm	kw
99.ST.8223	30	ER-25 - Ø1+16	✓	45	55	31	64	56	60	2	52	32	6.000	8
99.ST.8226	40	ER-32 - Ø2+20	✓	53	100	35	76	71	62	11	71	63	5.000	10
99.ST.8227	50	ER-40 - Ø3+30	✓	78	110	44	88	105	79,5	17	80,5	100	4.000	12
99.ST.8228	60	ER-50 - Ø7+34	✓	94	130	55	110	157	102	39	103	160	3.200	15

MODELLI DI TORNIO COMPATIBILI  
 COMPATIBLE LATHE TYPES

**VDI 20 / VDI 30 / VDI 40 / VDI 50 / VDI 60**

Vedi pagine compatibilità 5.10 / 5.13 - See compatibility pages 5.10 / 5.13

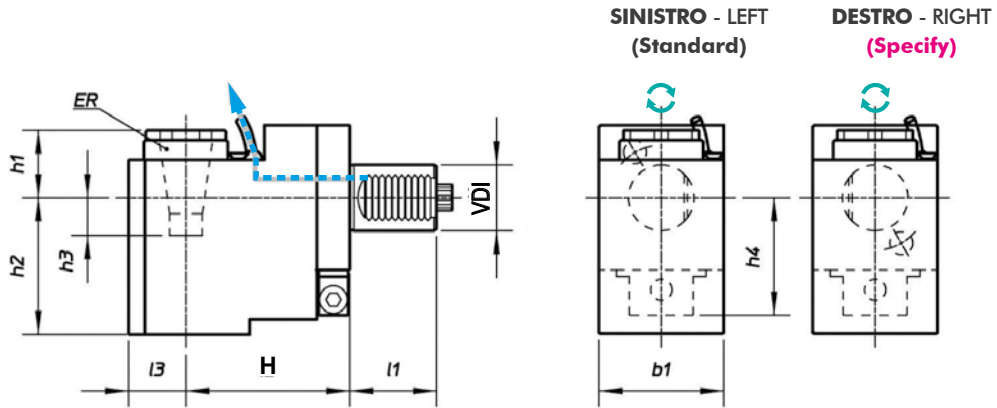
**VDI**  
**DIN 5482**

TIPO - TYPE

 Arretrato  
 Rear Offset

USCITA - OUTPUT

 Porta Pinza  
 Collet Chuck

 REFRIGERANTE  
 COOLANT

 Esterno  
 External

RATIO

1:1



ROTAZIONE - ROTATION

 Uguale al mandrino  
 Same as machine spindle

Code	VDI	Output	Int Cool.	l1	H	l3	b1	h1	h2	h3	h4	Nm	Rpm	kw
99.ST.8229	30	ER-25 - Ø1+16	NO	45	85	31	64	14,5	90	45	52	32	6.000	8
99.ST.8230	40	ER-32 - Ø2+20	NO	53	100	35	76	20	106	40	72,5	63	5.000	10
99.ST.8231	50	ER-40 - Ø3+30	NO	78	110	44	88	31	123	44	80,5	100	4.000	12
99.ST.8232	60	ER-50 - Ø7+34	NO	94	135	55	110	67	184	43	103	160	3.200	15

4

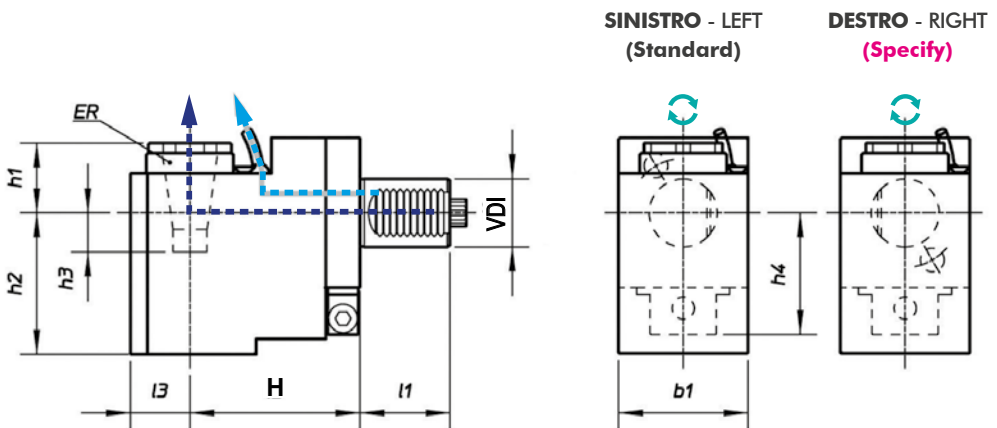

TIPO - TYPE

 Arretrato  
 Rear Offset

USCITA - OUTPUT

 Porta Pinza  
 Collet Chuck

 REFRIGERANTE  
 COOLANT

25 bar



RATIO

1:1



ROTAZIONE - ROTATION

 Uguale al mandrino  
 Same as machine spindle

Code	VDI	Output	Int Cool.	l1	H	l3	b1	h1	h2	h3	h4	Nm	Rpm	kw
99.ST.8233	30	ER-25 - Ø1+16	✓	45	85	31	64	24	105,5	45,5	52	32	6.000	8
99.ST.8234	40	ER-32 - Ø2+20	✓	53	100	35	76	30	124	40	72,5	63	5.000	10
99.ST.8235	50	ER-40 - Ø3+30	✓	78	110	44	88	44	140,5	44	80,5	100	4.000	12

MODELLI DI TORNIO COMPATIBILI  
 COMPATIBLE LATHE TYPES

**VDI 20 / VDI 30 / VDI 40 / VDI 50 / VDI 60**

Vedi pagine compatibilità 5.10 / 5.13 - See compatibility pages 5.10 / 5.13

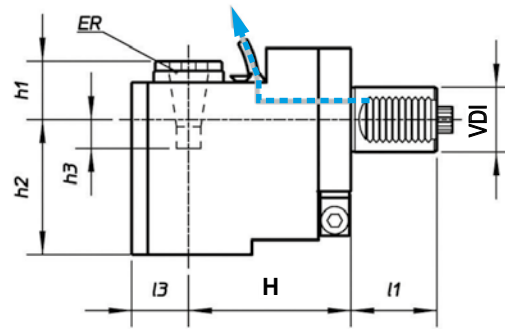
**VDI**  
**DIN 5482**

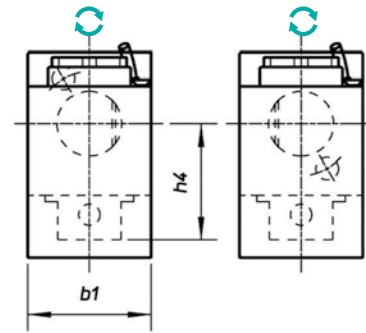
**SINISTRO - LEFT**  
 (Standard)

**DESTRO - RIGHT**  
 (Specify)

 TIPO - TYPE  
**Arretrato**  
 Rear Offset

 USCITA - OUTPUT  
**Porta Pinza**  
 Collet Chuck

 REFRIGERANTE  
 COOLANT  
**Esterno**  
 External

 RATIO  
**1:4**

 ROTAZIONE - ROTATION  
**Uguale al mandrino**  
 Same as machine spindle

Code	VDI	Output	Int Cool.	I1	H	I3	b1	h1	h2	h3	h4	Nm	Rpm	kw
99.ST.8237	30	ER-16 - Ø1+10	NO	45	95	21	64	33	84	15	56	8	20.000	4
99.ST.8238	40	ER-20 - Ø1+13	NO	53	125	27	76	45	108	10	65,5	16	16.000	5
99.ST.8239	50	ER-20 - Ø1+13	NO	78	135	27	86	45	113	10	73,5	25	16.000	6

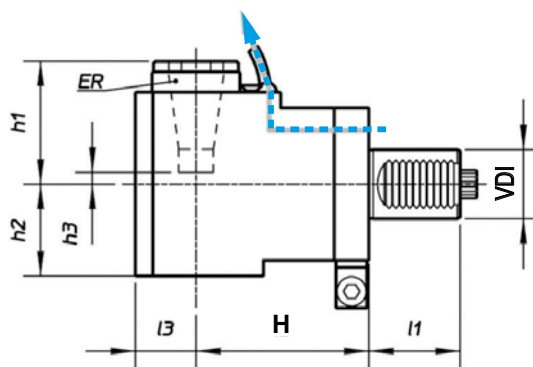
**4**

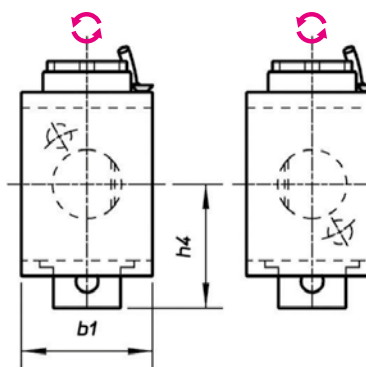
**SINISTRO - LEFT**  
 (Standard)

**DESTRO - RIGHT**  
 (Specify)

 TIPO - TYPE  
**Radiale**  
 Radial

 USCITA - OUTPUT  
**Porta Pinza**  
 Collet Chuck

 REFRIGERANTE  
 COOLANT  
**Esterno**  
 External

 RATIO  
**2:1**

 ROTAZIONE - ROTATION  
**Opposto al mandrino**  
 Opposite to machine spindle

Code	VDI	Output	Int Cool.	I1	H	I3	km	h1	h2	h3	h4	Nm	Rpm	kw
99.ST.8240	30	ER-25 - Ø1+16	NO	45	55	31	64	56,5	48	3	52	63	2.500	8
99.ST.8241	40	ER-32 - Ø2+20	NO	53	100	35	76	71	55	-11	72,5	63	2.000	8

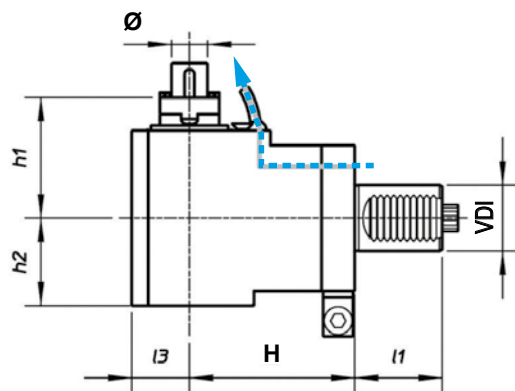

Vedi pagine compatibilità 5.10 / 5.13 - See compatibility pages 5.10 / 5.13

**SINISTRO - LEFT**  
 (Standard)

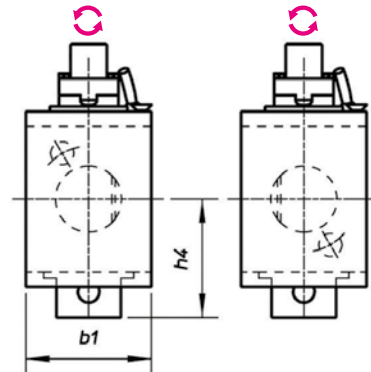
**DESTRO - RIGHT**  
 (Specify)

**VDI**  
**DIN 5482**

TIPO - TYPE

**Radiale**  
 Radial

USCITA - OUTPUT

**Porta Fresa**  
 Shell End Milling Cutter

 REFRIGERANTE  
 COOLANT

**Esterno**  
 External

RATIO

**1:1**



ROTAZIONE - ROTATION

**Opposto al mandrino**  
 Opposite to machine spindle

Code	VDI	Output	Int Cool.	l1	H	l3	b1	h1	h2	h4	Nm	Rpm	kw
99.ST.8242	30	Ø22	NO	45	55	31	64	74	48	52	63	2.500	8
99.ST.8243	40	Ø22	NO	53	100	35	76	78	55	72,5	63	2.000	8

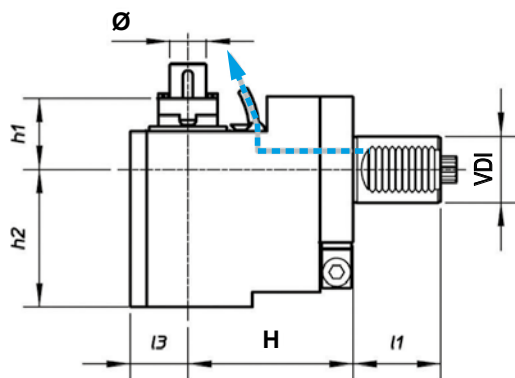
4

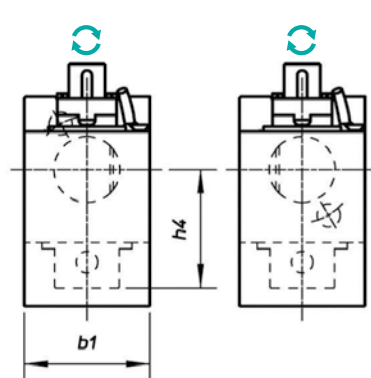
**SINISTRO - LEFT**  
 (Standard)

**DESTRO - RIGHT**  
 (Specify)

TIPO - TYPE

**Arretrato**  
 Rear Offset

USCITA - OUTPUT

**Porta Fresa**  
 Shell End Milling Cutter

 REFRIGERANTE  
 COOLANT

**Esterno**  
 External

RATIO

**1:1**

ROTAZIONE - ROTATION

**Ugale al mandrino**  
 Same as machine spindle

Code	VDI	Output	Int Cool.	l1	H	l3	b1	h1	h2	h4	Nm	Rpm	kw
99.ST.8244	30	Ø22	NO	45	85	31	64	32	90	52	32	2.500	8
99.ST.8245	40	Ø22	NO	53	100	35	76	27	106	72,5	63	4.000	10

MODELLI DI TORNIO COMPATIBILI  
COMPATIBLE LATHE TYPES

VDI 20 / VDI 30 / VDI 40 / VDI 50 / VDI 60



Vedi pagine compatibilità 5.10 / 5.13 - See compatibility pages 5.10 / 5.13

VDI  
DIN 5482

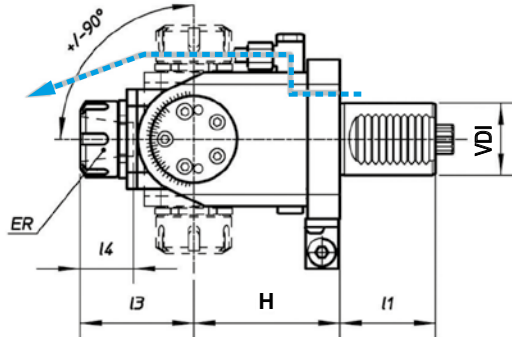
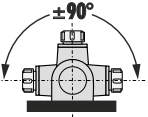

SINISTRO - LEFT  
(Standard)

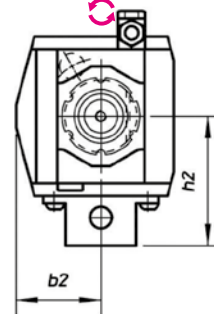

DESTRO - RIGHT  
(Specify)

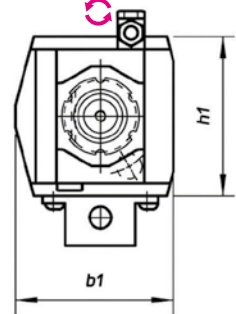

TIPO - TYPE  
**Orientabile**  
Adjustable  $\pm 90^\circ$



USCITA - OUTPUT  
**Porta Pinza**  
Collet Chunk



REFRIGERANTE  
COOLANT  
**Esterno**  
External



RATIO  
**1:1**



ROTAZIONE - ROTATION  
**Opposto al mandrino**  
Opposite to machine spindle

Code	VDI	Output	Int Cool.	I1	H	I3	I4	b1	b2	h1	h2	Nm	Rpm	kw
99.ST.8248	30	ER-20 - $\varnothing 1+13$	NO	45	64	52	37	70	37	64	54	15	6.000	3
99.ST.8249	30	ER-20 - $\varnothing 1+13$	NO	45	97	52	37	70	37	64	54	15	6.000	3
99.ST.8250	40	ER-25 - $\varnothing 1+16$	NO	53	81	63	42	87	47	88	71	25	6.000	4
99.ST.8251	50	ER-25 - $\varnothing 1+16$	NO	78	100	67	47	91	54	88	72	25	4.000	6

4

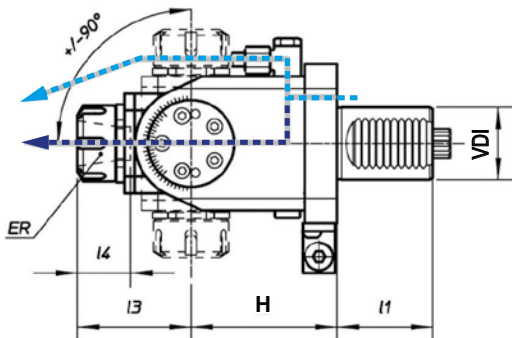
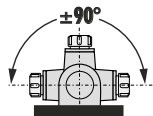

SINISTRO - LEFT  
(Standard)

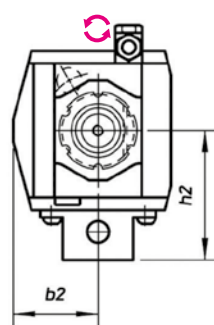

DESTRO - RIGHT  
(Specify)

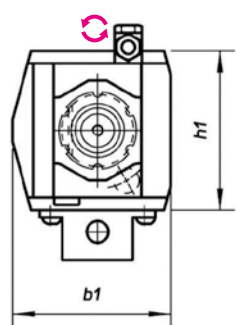

TIPO - TYPE  
**Orientabile**  
Adjustable  $\pm 90^\circ$



USCITA - OUTPUT  
**Porta Pinza**  
Collet Chunk



REFRIGERANTE  
COOLANT  
**25 bar**



RATIO  
**1:1**



ROTAZIONE - ROTATION  
**Opposto al mandrino**  
Opposite to machine spindle

Code	VDI	Output	Int Cool.	I1	H	I3	I4	b1	b2	h1	h2	Nm	Rpm	kw
99.ST.8254	30	ER-20 - $\varnothing 1+13$	✓	45	97	52	37	70	37	64	54	15	6.000	3
99.ST.8255	40	ER-25 - $\varnothing 1+16$	✓	53	81	63	42	87	47	88	71	25	6.000	4

TORRETTA TIPO / TURRET TYPE  
DIN 6380 (VDI STANDARD)



BARUFFALDI



DIN 5480

DIN 5482

DIN 1809

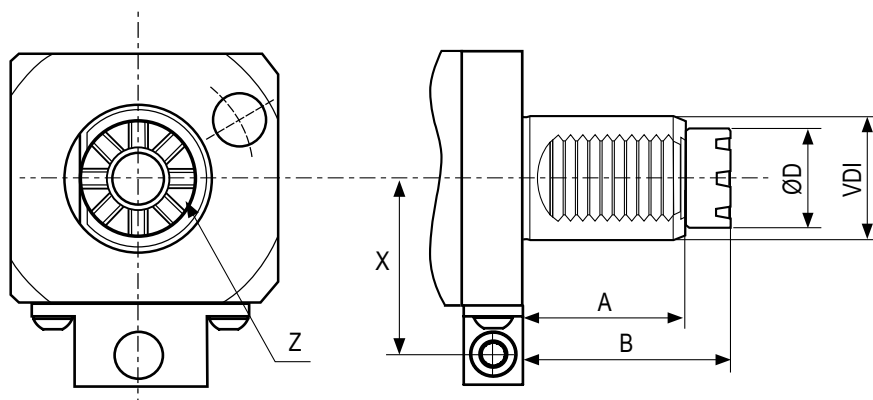

VDI	A	B	ØD	Z (N° denti - Teeth)	X
20	35	44	19	6	50
30	45	59	24	6	40
40	53	68	32	8	63
50	70	84	40	8	70
60	83	100	43	8	-



**DOTAZIONE STANDARD**  
STANDARD EQUIPMENT

Chiave bloccaggio albero Art.179CH /  
ugello refrigerazione Art.180 / vite bloccaggio ugello  
Art.179CH shaft lock wrench /  
cooling nozzle Art.180 / nozzle lock screws



**CAMBI RAPIDI MODULARI** Vedi pag. 7.12 - 7.15  
MODULAR QUICK CHANGE See page 7.12 - 7.15

Facile e veloce sistema modulare per il cambio rapido delle diverse  
tipologie di portautensili con la sede per pinza ER (DIN6499).  
Modular toolholder system for the fitting of toolholders in  
a spindle unit with ER collets (DIN6499) outputs.



MODELLI DI TORNIO COMPATIBILI  
 COMPATIBLE LATHE TYPES

**VDI 20 / VDI 30 / VDI 40 / VDI 50 / VDI 60**

Vedi pagine compatibilità 5.10 / 5.13 - See compatibility pages 5.10 / 5.13

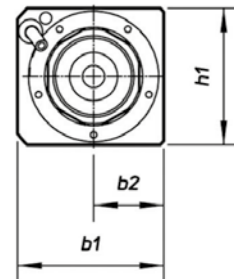
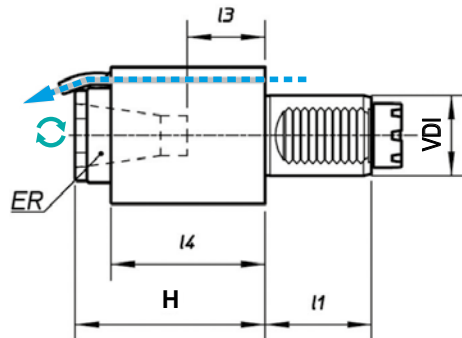
**BARUFFALDI**

Per dischi assiali - For axial tool discs



TIPO - TYPE

 Assiale  
 Axial

USCITA - OUTPUT

 Porta Pinza  
 Collet Chuck

 REFRIGERANTE  
 COOLANT

 Esterno  
 External

RATIO

1:1



ROTAZIONE - ROTATION

 Uguale al mandrino  
 Same as machine spindle

Code	VDI	Output	Int Cool.	l1	H	l3	l4	b1	b2	h1	Nm	Rpm	kw
99.BF.0001	20	ER-20 - Ø1+13	NO	35	90	49	61	50	25	56	13	6.000	5
99.BF.0002	20	ER-20 - Ø1+13	NO	35	65	25	37	50	25	56	13	6.000	5
99.BF.0003	30	ER-25 - Ø1+16	NO	45	94	39	88	62	31	64	32	6.000	8
99.BF.0005	40	ER-32 - Ø2+20	NO	53	117	57	99	73	35	70	63	5.000	10
99.BF.0007	50	ER-40 - Ø3+30	NO	70	120	45	102	88	44	88	100	4.000	12
99.BF.0009	60	ER-50 - Ø7+34	NO	83	170	69	109	110	55	110	160	3.200	15

4

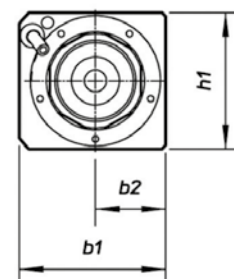
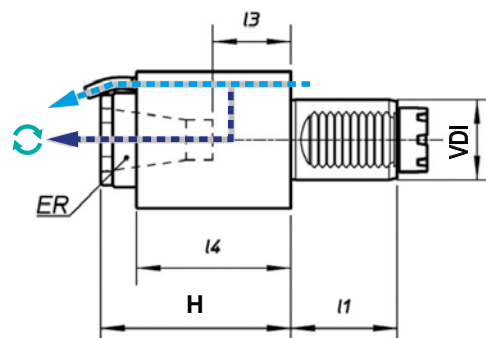

Per dischi assiali - For axial tool discs



TIPO - TYPE

 Assiale  
 Axial

USCITA - OUTPUT

 Porta Pinza  
 Collet Chuck

 REFRIGERANTE  
 COOLANT

25 bar



RATIO

1:1



ROTAZIONE - ROTATION

 Uguale al mandrino  
 Same as machine spindle

Code	VDI	Output	Int Cool.	l1	H	l3	l4	b1	b2	h1	Nm	Rpm	kw
99.BF.0010	30	ER-25 - Ø1+16	✓	45	94	39	88	62	31	64	32	6.000	8
99.BF.0011	40	ER-32 - Ø2+20	✓	53	115	54	97	73	35	70	63	5.000	10
99.BF.0013	50	ER-40 - Ø3+30	✓	70	120	45	102	88	44	88	100	4.000	12
99.BF.0014	60	ER-50 - Ø7+34	✓	83	170	69	109	110	55	110	160	3.200	15

MODELLI DI TORNIO COMPATIBILI  
 COMPATIBLE LATHE TYPES

**VDI 20 / VDI 30 / VDI 40 / VDI 50 / VDI 60**

Vedi pagine compatibilità 5.10 / 5.13 - See compatibility pages 5.10 / 5.13

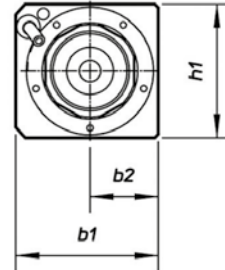
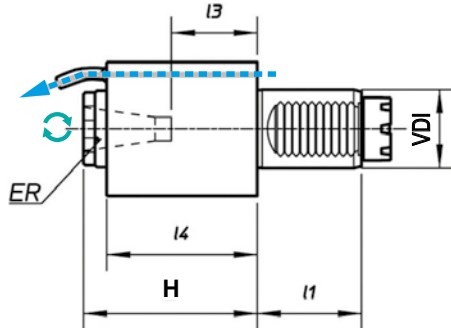
**BARUFFALDI**

Per dischi assiali - For axial tool discs

Code	VDI	Output	Int Cool.	l1	H	l3	l4	b1	b2	h1	Nm	Rpm	kw
99.BF.0015	20	ER-16 - Ø1+10	NO	35	100	68	85	50	25	56	3	24.000	3
99.BF.0016	30	ER-16 - Ø1+10	NO	45	100	58	88	62	31	64	8	20.000	4
99.BF.0017	40	ER-20 - Ø1+13	NO	53	112,5	74,5	106	76	38	76	16	16.000	5

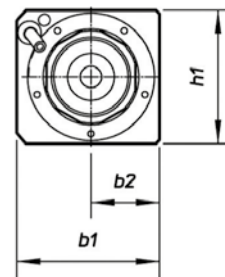
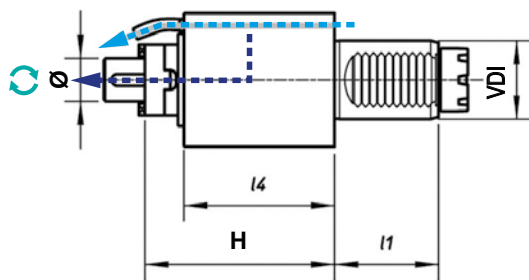

Per dischi assiali - For axial tool discs

Code	VDI	Output	Int Cool.	l1	H	l4	b1	b2	h1	Nm	Rpm	kw
99.BF.0018	30	Ø22	✓	45	112	88	62	31	64	32	5.000	8

4

MODELLI DI TORNIO COMPATIBILI  
 COMPATIBLE LATHE TYPES

VDI 20 / VDI 30 / VDI 40 / VDI 50 / VDI 60



Vedi pagine compatibilità 5.10 / 5.13 - See compatibility pages 5.10 / 5.13

BARUFFALDI

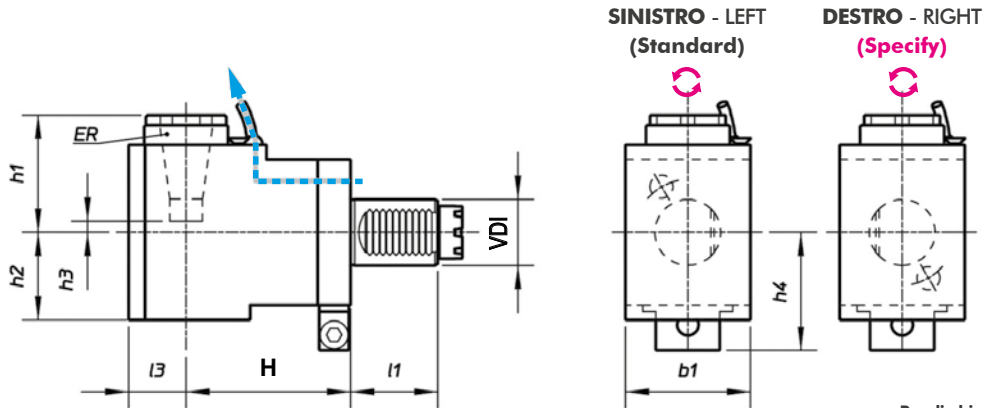

Per dischi assiali - For axial tool discs

 TIPO - TYPE  
**Radiale**  
 Radial

 USCITA - OUTPUT  
**Porta Pinza**  
 Collet Chuck

 REFRIGERANTE  
 COOLANT  
**Esterno**  
 External

 RATIO  
**1:1**

 ROTAZIONE - ROTATION  
**Opposto al mandrino**  
 Opposite to machine spindle

Code	VDI	Output	Int Cool.	I1	H	I3	b1	h1	h2	h3	h4	Nm	Rpm	kw
99.BF.0020	20	ER-20 - Ø1+13	NO	35	60	25	50	60	38	19	57	13	6.000	5
99.BF.0021	30	ER-25 - Ø1+16	NO	45	55	31	64	56	48	3	52	32	6.000	8
99.BF.0022	30	ER-25 - Ø1+16	NO	45	85	31	64	56	48	3	52	32	6.000	8
99.BF.0023	30	ER-25 - Ø1+16	NO	45	100	31	64	56	48	3	52	32	6.000	8
99.BF.0024	40	ER-32 - Ø2+20	NO	53	100	35	76	71	55	11	71	63	5.000	10
99.BF.0025	50	ER-40 - Ø3+30	NO	70	110	44	88	92	73	16	79	100	4.000	12
99.BF.0026	60	ER-50 - Ø7+34	NO	83	130	52	110	149	83	46	100	160	3.200	15

4

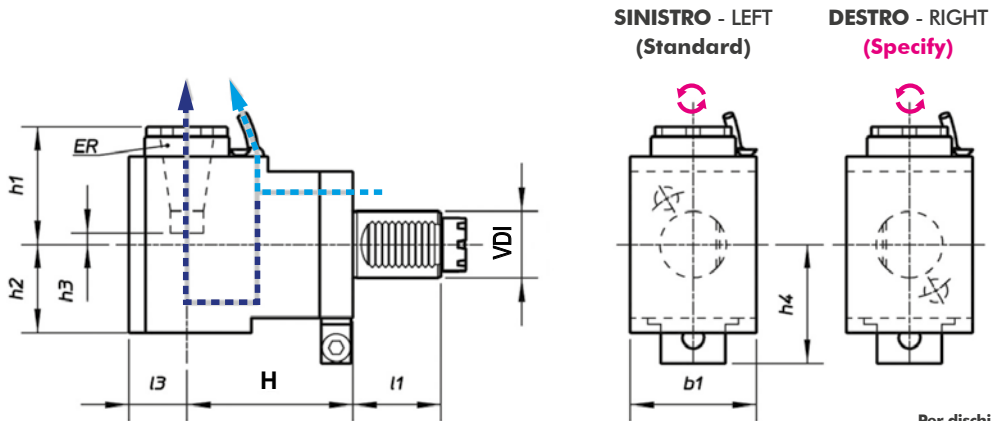

Per dischi assiali - For axial tool discs

 TIPO - TYPE  
**Radiale**  
 Radial

 USCITA - OUTPUT  
**Porta Pinza**  
 Collet Chuck

 REFRIGERANTE  
 COOLANT  
**25 bar**

 RATIO  
**1:1**

 ROTAZIONE - ROTATION  
**Opposto al mandrino**  
 Opposite to machine spindle

Code	VDI	Output	Int Cool.	I1	H	I3	b1	h1	h2	h3	h4	Nm	Rpm	kw
99.BF.0027	30	ER-25 - Ø1+16	✓	45	55	31	64	56	60	3	52	32	6.000	8
99.BF.0028	30	ER-25 - Ø1+16	✓	45	85	31	64	56	60	3	52	32	6.000	8
99.BF.0029	30	ER-25 - Ø1+16	✓	45	100	31	64	56	60	3	52	32	6.000	8
99.BF.0030	40	ER-32 - Ø2+20	✓	53	100	35	76	71	62	11	71	63	5.000	10
99.BF.0031	50	ER-40 - Ø3+30	✓	70	110	44	88	92	73	16	79	100	4.000	12
99.BF.0032	60	ER-50 - Ø7+34	✓	83	130	52	110	149	83	46	100	160	3.200	15



Vedi pagine compatibilità 5.10 / 5.13 - See compatibility pages 5.10 / 5.13

BARUFFALDI

**SINISTRO - LEFT**  
 (Standard)

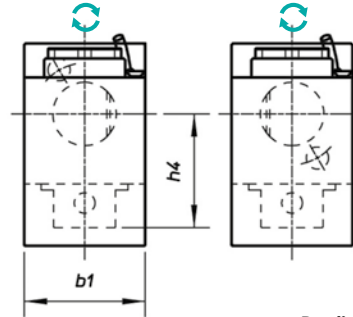
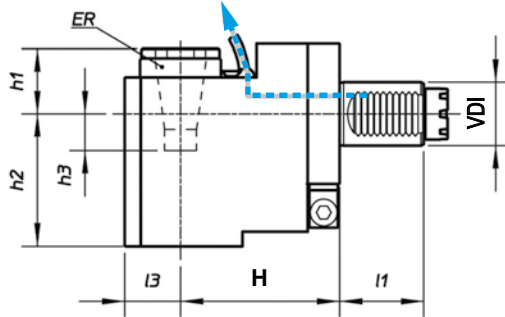
**DESTRO - RIGHT**  
 (Specify)

Per dischi assiali - For axial tool discs



TIPO - TYPE

 Arretrato  
 Rear Offset

USCITA - OUTPUT

 Porta Pinza  
 Collet Chuck

 REFRIGERANTE  
 COOLANT

 Esterno  
 External

RATIO

1:1



ROTAZIONE - ROTATION

 Uguale al mandrino  
 Same as machine spindle

Code	VDI	Output	Int Cool.	l1	H	l3	b1	h1	h2	h3	h4	Nm	Rpm	kw
99.BF.0033	20	ER-16 - Ø1+10	NO	35	75	26	50	28	48	4	56	13	6.000	5
99.BF.0034	30	ER-25 - Ø1+16	NO	45	85	31	64	14,5	90	45	52	32	5.000	8
99.BF.0035	40	ER-32 - Ø2+20	NO	53	100	35	76	20	106	40	72,5	63	4.000	10
99.BF.0036	50	ER-40 - Ø3+30	NO	70	110	44	88	31	136	46	79	100	4.000	12

4

**SINISTRO - LEFT**  
 (Standard)

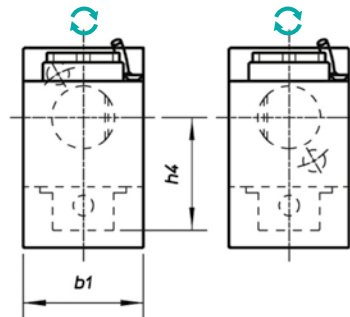
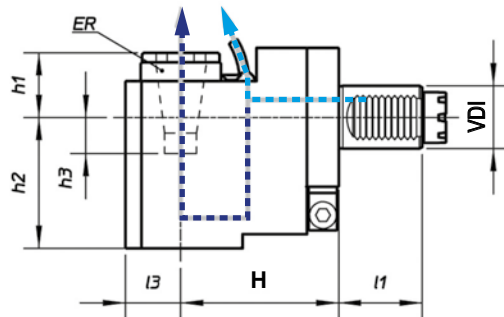
**DESTRO - RIGHT**  
 (Specify)

Per dischi assiali - For axial tool discs



TIPO - TYPE

 Arretrato  
 Rear Offset

USCITA - OUTPUT

 Porta Pinza  
 Collet Chuck

 REFRIGERANTE  
 COOLANT

25 bar



RATIO

1:1



ROTAZIONE - ROTATION

 Uguale al mandrino  
 Same as machine spindle

Code	VDI	Output	Int Cool.	l1	H	l3	b1	h1	h2	h3	h4	Nm	Rpm	kw
99.BF.0037	30	ER-25 - Ø1+16	✓	45	85	31	64	24	105,5	45,5	52	32	5.000	8
99.BF.0038	40	ER-32 - Ø2+20	✓	53	100	35	76	30	124	40	72,5	63	4.000	10
99.BF.0039	50	ER-40 - Ø3+30	✓	70	110	44	88	44	136	46	79	100	4.000	12

MODELLI DI TORNIO COMPATIBILI  
 COMPATIBLE LATHE TYPES

**VDI 20 / VDI 30 / VDI 40 / VDI 50 / VDI 60**

Vedi pagine compatibilità 5.10 / 5.13 - See compatibility pages 5.10 / 5.13

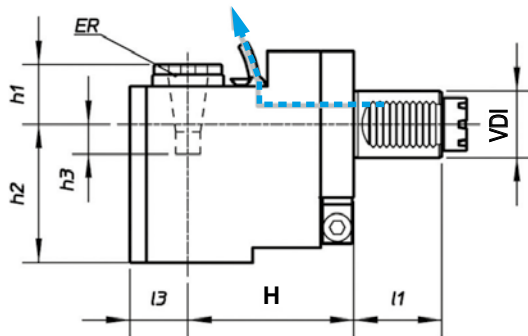

BARUFFALDI

**SINISTRO - LEFT**  
 (Standard)

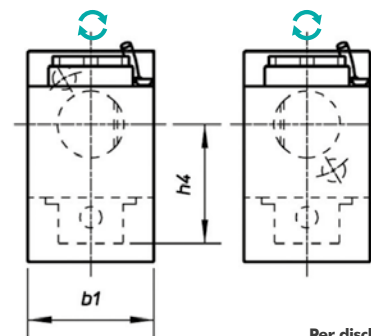
**DESTRO - RIGHT**  
 (Specify)

Per dischi assiali - For axial tool discs

 TIPO - TYPE  
**Arretrato**  
 Rear Offset

 USCITA - OUTPUT  
**Porta Pinza**  
 Collet Chuck

 REFRIGERANTE  
 COOLANT  
**Esterno**  
 External

 RATIO  
**1:4**

 ROTAZIONE - ROTATION  
**Uguale al mandrino**  
 Same as machine spindle

Code	VDI	Output	Int Cool.	l1	H	l3	b1	h1	h2	h3	h4	Nm	Rpm	kw
99.BF.0040	20	ER-25 - Ø1+16	NO	35	75	26	50	28	48	4	56	3	24.000	3
99.BF.0041	30	ER-25 - Ø1+16	NO	45	95	21	64	33	84	15	56	8	20.000	4
99.BF.0042	40	ER-20 - Ø1+13	NO	53	125	27	76	45	108	10	65,5	16	16.000	5

4

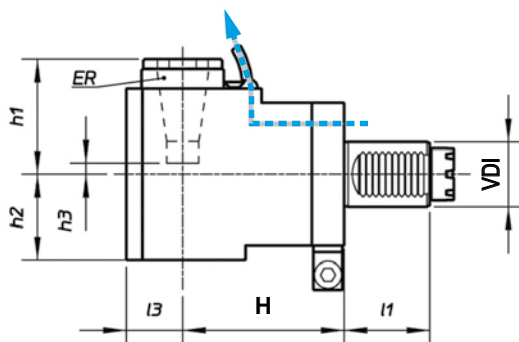
**SINISTRO - LEFT**  
 (Standard)

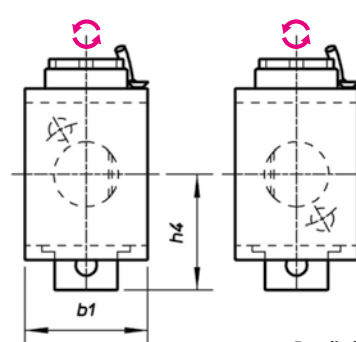
**DESTRO - RIGHT**  
 (Specify)

Per dischi assiali - For axial tool discs

 TIPO - TYPE  
**Radiale**  
 Radial

 USCITA - OUTPUT  
**Porta Pinza**  
 Collet Chuck

 REFRIGERANTE  
 COOLANT  
**Esterno**  
 External

 RATIO  
**2:1**

 ROTAZIONE - ROTATION  
**Opposto al mandrino**  
 Opposite to machine spindle

Code	VDI	Output	Int Cool.	l1	H	l3	b1	h1	h2	h3	h4	Nm	Rpm	kw
99.BF.0043	30	ER-25 - Ø1+16	NO	45	55	31	64	56,5	48	3	52	63	2.500	8
99.BF.0044	40	ER-32 - Ø2+20	NO	53	100	35	76	71	55	-11	72,5	63	2.000	8

MODELLI DI TORNIO COMPATIBILI  
 COMPATIBLE LATHE TYPES

**VDI 20 / VDI 30 / VDI 40 / VDI 50 / VDI 60**

Vedi pagine compatibilità 5.10 / 5.13 - See compatibility pages 5.10 / 5.13

BARUFFALDI

**SINISTRO - LEFT**  
 (Standard)

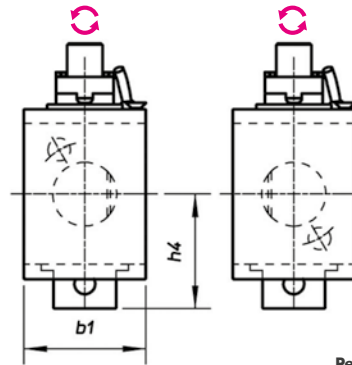
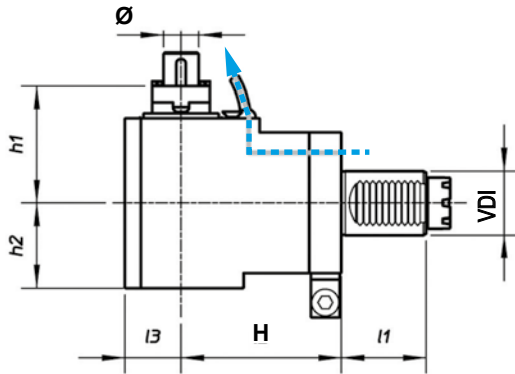
**DESTRO - RIGHT**  
 (Specify)

Per dischi assiali - For axial tool discs

	TIPO - TYPE		USCITA - OUTPUT		REFRIGERANTE COOLANT		RATIO		ROTAZIONE - ROTATION
	Radiale Radial		Porta Fresa Shell End Milling Cutter		Esterno External		2:1		Opposto al mandrino Opposite to machine spindle

Code	VDI	Output	Int Cool.	I1	H	I3	b1	h1	h2	h4	Nm	Rpm	kw
99.BF.0045	30	Ø22	NO	45	55	31	64	74	48	52	63	2.500	8
99.BF.0046	40	Ø22	NO	53	100	35	76	78	55	72,5	63	2.000	8

**SINISTRO - LEFT**  
 (Standard)

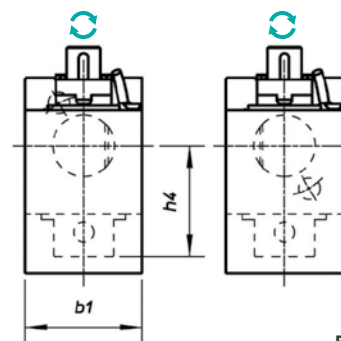
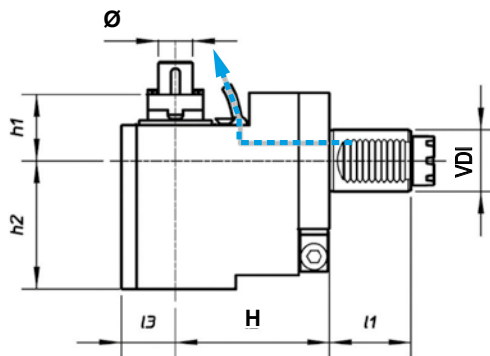
**DESTRO - RIGHT**  
 (Specify)

Per dischi assiali - For axial tool discs

	TIPO - TYPE		USCITA - OUTPUT		REFRIGERANTE COOLANT		RATIO		ROTAZIONE - ROTATION
	Arretrato Rear Offset		Porta Fresa Shell End Milling Cutter		Esterno External		1:1		Uguale al mandrino Same as machine spindle

Code	VDI	Output	Int Cool.	I1	H	I3	b1	h1	h2	h4	Nm	Rpm	kw
99.BF.0047	30	Ø22	NO	45	85	31	64	32	90	52	32	2500	8



MODELLI DI TORNIO COMPATIBILI  
 COMPATIBLE LATHE TYPES

**VDI 20 / VDI 30 / VDI 40 / VDI 50 / VDI 60**

Vedi pagine compatibilità 5.10 / 5.13 - See compatibility pages 5.10 / 5.13

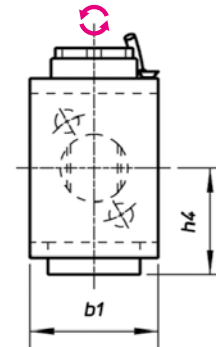
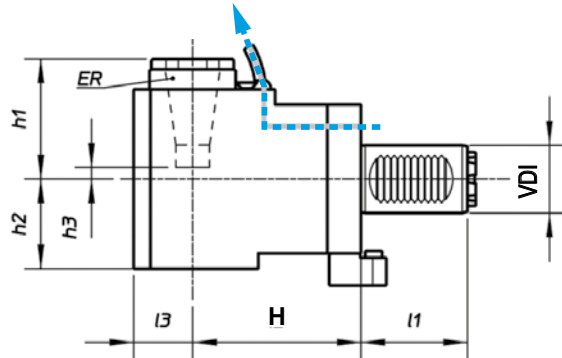

Per dischi radiali - For radial tool discs

 TIPO - TYPE  
**Radiale**  
 Radial

 USCITA - OUTPUT  
**Porta Pinza**  
 Collet Chuck

 REFRIGERANTE  
 COOLANT  
**Esterno**  
 External

 RATIO  
**1:1**

 ROTAZIONE - ROTATION  
**Opposto al mandrino**  
 Opposite to machine spindle

Code	VDI	Output	Int Cool.	I1	H	I3	b1	h1	h2	h3	h4	Nm	Rpm	kw
99.BF.0057	30	ER-25 - Ø1+16	NO	53	55	31	64	56	48	3	53	32	6000	8
99.BF.0058	30	ER-25 - Ø1+16	NO	53	85	31	64	56	48	3	53	32	6000	8
99.BF.0059	30	ER-25 - Ø1+16	NO	53	100	31	64	56	48	3	53	32	6000	8
99.BF.0060	50	ER-40 - Ø3+30	NO	70	110	44	88	92	73	16	68	100	4000	12

4

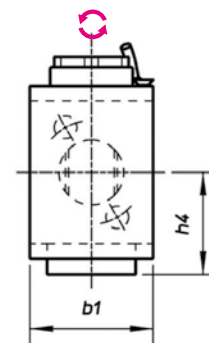
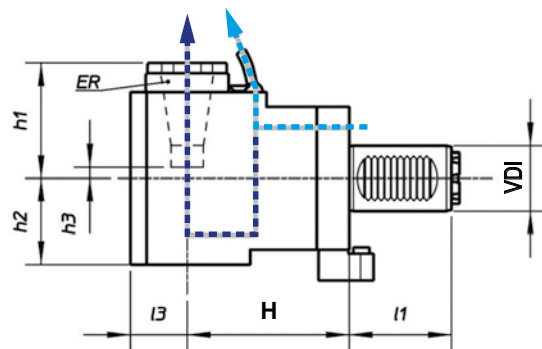

Per dischi radiali - For radial tool discs

 TIPO - TYPE  
**Radiale**  
 Radial

 USCITA - OUTPUT  
**Porta Pinza**  
 Collet Chuck

 REFRIGERANTE  
 COOLANT  
**25 bar**

 RATIO  
**1:1**

 ROTAZIONE - ROTATION  
**Opposto al mandrino**  
 Opposite to machine spindle

Code	VDI	Output	Int Cool.	I1	H	I3	b1	h1	h2	h3	h4	Nm	Rpm	kw
99.BF.0062	30	ER-25 - Ø1+16	✓	53	85	31	64	56	60	3	53	32	6000	8
99.BF.0063	30	ER-25 - Ø1+16	✓	53	100	31	64	56	60	3	53	32	6000	8
99.BF.0064	50	ER-40 - Ø3+30	✓	70	110	44	88	92	62	16	68	100	4000	12

**MODELLI DI TORNIO COMPATIBILI**  
 COMPATIBLE LATHE TYPES

**VDI 20 / VDI 30 / VDI 40 / VDI 50 / VDI 60**

Vedi pagine compatibilità 5.10 / 5.13 - See compatibility pages 5.10 / 5.13

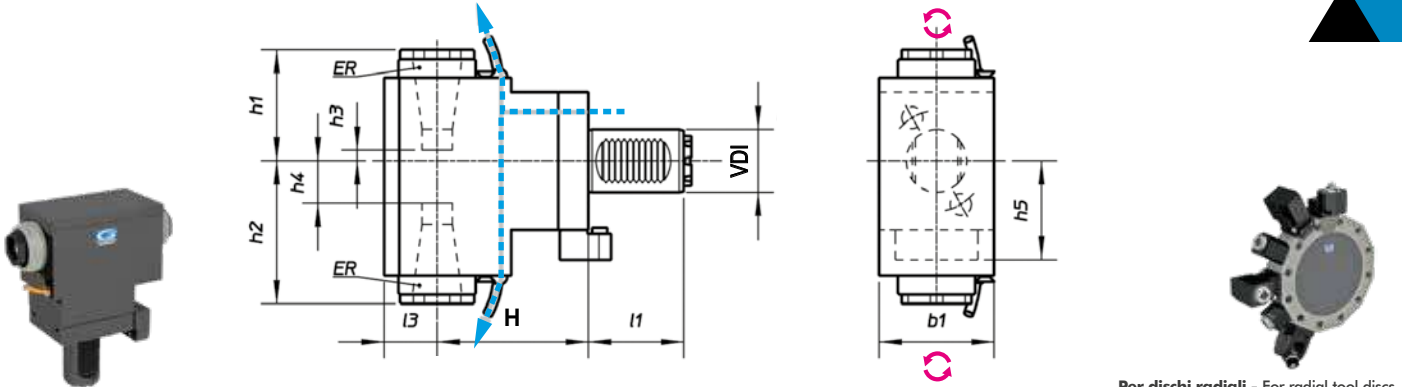
**BARUFFALDI**

Per dischi radiali - For radial tool discs

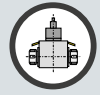

TIPO - TYPE

**Radiale Doppio**  
 Double Radial

USCITA - OUTPUT

**Porta Pinza**  
 Collet Chuck

 REFRIGERANTE  
 COOLANT

**Esterno**  
 External

RATIO

**1:1**

ROTAZIONE - ROTATION

**Opposto al mandrino**  
 Opposite to machine spindle

Code	VDI	Output	Int Cool.	l1	H	l3	b1	h1	h2	h3	h4	h5	Nm	Rpm	kw	
99.BF.0067	30	ER-25 - Ø1+16	NO	53	110	31	64	56	68	7	23	53	32	6000	8	
99.BF.0068	50	ER-40 - Ø3+30	NO	70	140	44	88	93	106	39	52	68	100	4000	12	

**MODELLI DI TORNIO COMPATIBILI**  
 COMPATIBLE LATHE TYPES

**VDI 20 / VDI 30 / VDI 40 / VDI 50 / VDI 60**

Vedi pagine compatibilità 5.10 / 5.13 - See compatibility pages 5.10 / 5.13

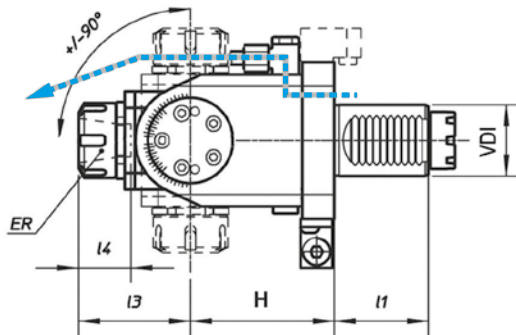
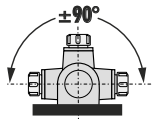
**BARUFFALDI**

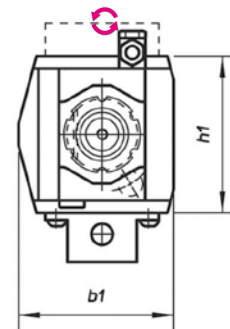
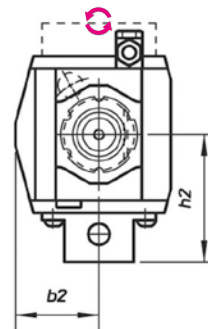
**SINISTRO - LEFT**  
 (Standard)

**DESTRO - RIGHT**  
 (Specify)

TIPO - TYPE

 Orientabile  
 Adjustable  $\pm 90^\circ$ 

USCITA - OUTPUT

 Porta Pinza  
 Collet Chuck

 REFRIGERANTE  
 COOLANT

 Esterno  
 External

RATIO

1:1



ROTAZIONE - ROTATION

 Opposto al mandrino  
 Opposite to machine spindle

Code	VDI	Output	Int Cool.	l1	H	l3	l4	b1	b2	h1	h2	Nm	Rpm	kw
99.BF.0051	30	ER-20 - $\varnothing 1+13$	NO	45	64	52	37	70	37	64	54	15	6.000	3
99.BF.0052	30	ER-20 - $\varnothing 1+13$	NO	45	97	52	37	70	37	64	54	15	6.000	3
99.BF.0053	40	ER-25 - $\varnothing 1+16$	NO	53	81	63	42	87	47	88	71	25	6.000	4

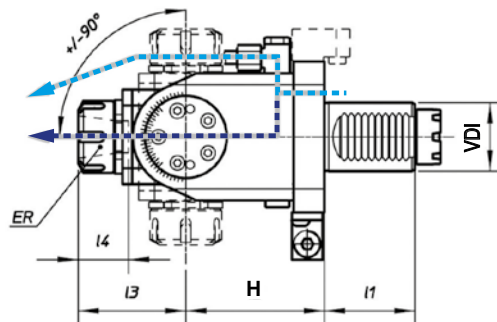
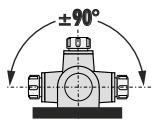
**SINISTRO - LEFT**  
 (Standard)

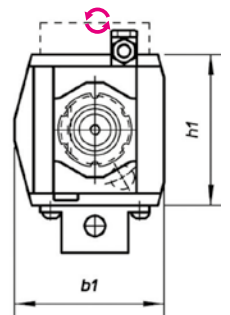
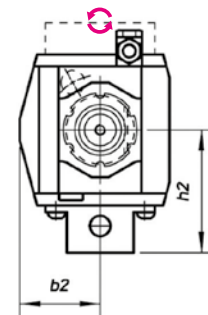
**DESTRO - RIGHT**  
 (Specify)

TIPO - TYPE

 Orientabile  
 Adjustable  $\pm 90^\circ$ 

USCITA - OUTPUT

 Porta Pinza  
 Collet Chuck

 REFRIGERANTE  
 COOLANT

25 bar



RATIO

1:1



ROTAZIONE - ROTATION

 Opposto al mandrino  
 Opposite to machine spindle

Code	VDI	Output	Int Cool.	l1	H	l3	l4	b1	b2	h1	h2	Nm	Rpm	kw
99.BF.0054	30	ER-20 - $\varnothing 1+13$	✓	45	64	52	37	70	37	64	54	15	6.000	3
99.BF.0055	30	ER-20 - $\varnothing 1+13$	✓	45	97	52	37	70	37	64	54	15	6.000	3
99.BF.0056	40	ER-25 - $\varnothing 1+16$	✓	53	81	63	42	87	47	88	71	25	6.000	4

TORRETTA TIPO / TURRET TYPE  
DIN69880 (VDI STANDARD)



DIN 1809



DIN 5480

DIN 5482

BARUFFALDI

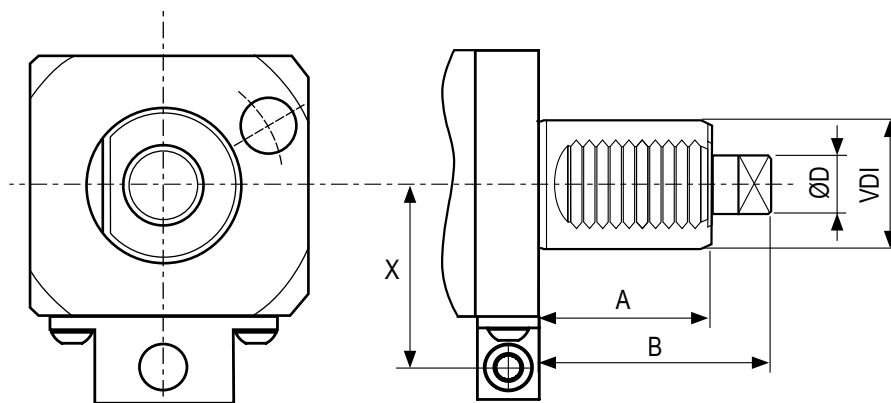

VDI	A	B	ØD	E	X
20	35	48	10	5	40
30	45	62	12	6	40
40 *	53	72	18	8	56 / 63 *
50	78	92	24	13	63
60	83	110	29	14	-

\* VDI40: Specificare interasse X in fase d'ordine - Specify always the "X" pitch you need



**DOTAZIONE STANDARD**  
STANDARD EQUIPMENT

Chiave bloccaggio albero Art.179CH /  
ugello refrigerazione Art.180 / vite bloccaggio ugello  
Art.179CH shaft lock wrench /  
cooling nozzle Art.180 / nozzle lock screws



**CAMBI RAPIDI MODULARI** Vedi pag. 7.12 - 7.15  
MODULAR QUICK CHANGE See page 7.12 - 7.15

Facile e veloce sistema modulare per il cambio rapido delle diverse  
tipologie di portautensili con la sede per pinza ER (DIN6499).  
Modular toolholder system for the fitting of toolholders in  
a spindle unit with ER collets (DIN6499) outputs.

MODELLI DI TORNIO COMPATIBILI  
COMPATIBLE LATHE TYPES

VDI 20 / VDI 25 / VDI 30 / VDI 50 / VDI 60



Vedi pagine compatibilità 5.10 / 5.13 - See compatibility pages 5.10 / 5.13

**VDI**  
DIN 1809

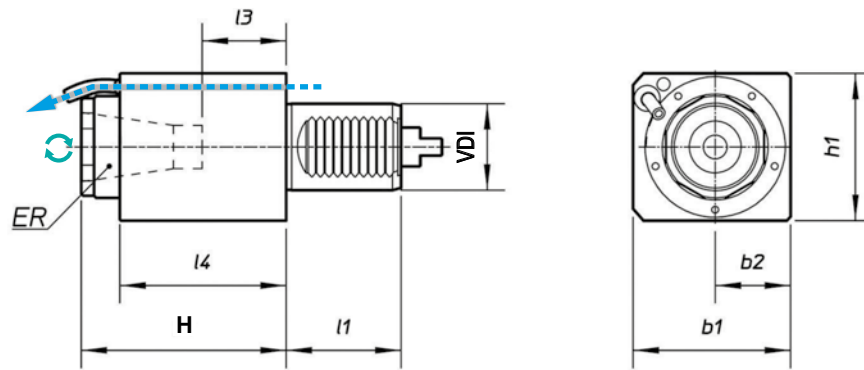

TIPO - TYPE  
Assiale  
Axial



USCITA - OUTPUT  
Porta Pinza  
Collet Chuck



REFRIGERANTE  
COOLANT  
Esterno  
External



RATIO  
1:1  
1:4



ROTAZIONE - ROTATION  
Uguale al mandrino  
Same as machine spindle

Code	VDI	Output	Int Cool.	I1	H	I3	I4	b1	b2	h1	Nm	Rpm	kw
99.DP.0901	20	ER-20 - Ø1+13	NO	35	65	25	37	50	25	56	13	6000	5
99.DP.0902	20	ER-20 - Ø1+13	NO	35	90	49	61	50	25	56	13	6000	5
99.DP.0903	30	ER-25 - Ø1+16	NO	45	94	39	88	62	31	64	32	6000	8
99.DP.0904	30	ER-25 - Ø1+16	NO	45	66	21	59	62	31	64	32	6000	8
99.DP.0905	40	ER-32 - Ø2+20	NO	53	115	54	97	73	35	70	63	5000	10
99.DP.0907	50	ER-40 - Ø3+30	NO	70	120	45	102	88	44	88	100	4000	12
99.DP.0908	50	ER-40 - Ø3+30	NO	70	88	69	25	88	44	88	100	4000	12
99.DP.0909	60	ER-50 - Ø7+34	NO	83	170	69	109	110	55	110	160	3200	15
99.DP.0915	20	ER-16 - Ø1+10	NO	35	100	68	85	50	25	56	3	24000	3
99.DP.0916	30	ER-16 - Ø1+10	NO	45	100	58	88	62	31	64	8	20000	4

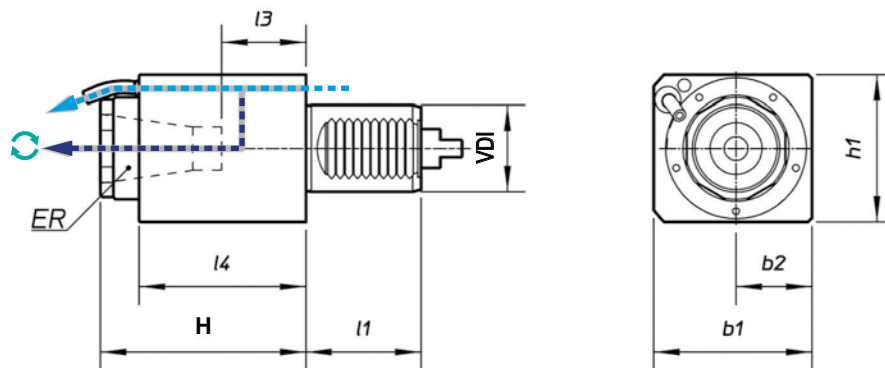

TIPO - TYPE  
Assiale  
Axial



USCITA - OUTPUT  
Porta Pinza  
Collet Chuck



REFRIGERANTE  
COOLANT  
25 bar



RATIO  
1:1



ROTAZIONE - ROTATION  
Uguale al mandrino  
Same as machine spindle

Code	VDI	Output	Int Cool.	I1	H	I3	I4	b1	b2	h1	Nm	Rpm	kw
99.DP.0910	30	ER-25 - Ø1+16	✓	45	94	39	88	62	31	64	32	6000	8
99.DP.0911	40	ER-32 - Ø2+20	✓	53	115	54	97	73	35	70	63	5000	10
99.DP.0913	50	ER-40 - Ø3+30	✓	70	120	45	102	88	44	88	100	4000	12
99.DP.0914	60	ER-50 - Ø7+34	✓	83	170	69	109	110	55	110	160	3200	15

**MODELLI DI TORNIO COMPATIBILI**  
 COMPATIBLE LATHE TYPES

**VDI 20 / VDI 25 / VDI 30 / VDI 50 / VDI 60**

Vedi pagine compatibilità 5.10 / 5.13 - See compatibility pages 5.10 / 5.13

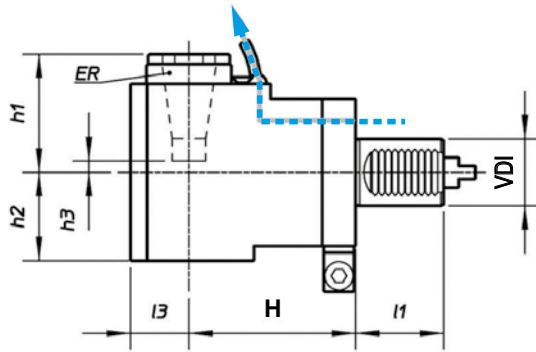
**SINISTRO - LEFT**  
 (Standard)

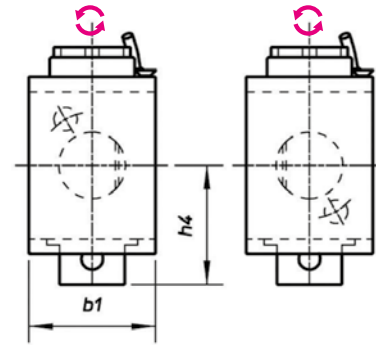
**DESTRO - RIGHT**  
 (Specify)

**VDI**  
**DIN 1809**

 TIPO - TYPE  
**Radiale**  
 Radial

 USCITA - OUTPUT  
**Porta Pinza**  
 Collet Chuck

 REFRIGERANTE  
 COOLANT  
**Esterno**  
 External

 RATIO  
**1:1**

 ROTAZIONE - ROTATION  
**Opposto al mandrino**  
 Opposite to machine spindle

Code	VDI	Output	Int Cool.	I1	H	I3	b1	h1	h2	h3	h4	Nm	Rpm	kw
99.DP.0918	20	ER-20 - Ø1+13	NO	35	60	25	50	60	38	19	57	13	6000	5
99.DP.0919	30	ER-25 - Ø1+16	NO	45	55	31	64	56	48	3	52	32	6000	8
99.DP.0920	30	ER-25 - Ø1+16	NO	45	85	31	64	56	48	3	52	32	6000	8
99.DP.0921	30	ER-25 - Ø1+16	NO	45	100	31	64	56	48	3	52	32	6000	8
99.DP.0922	40	ER-32 - Ø2+20	NO	53	100	35	76	71	55	11	71	63	6000	10
99.DP.0923	50	ER-40 - Ø3+30	NO	70	110	44	88	92	73	16	79	100	4000	12
99.DP.0924	60	ER-50 - Ø7+34	NO	83	130	52	110	149	83	46	100	160	3200	15

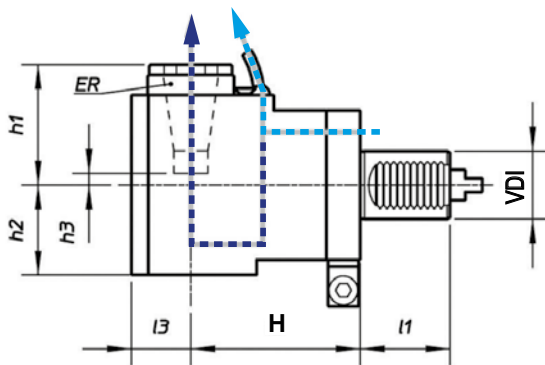
**SINISTRO - LEFT**  
 (Standard)

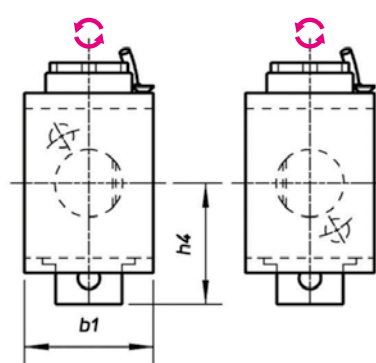
**DESTRO - RIGHT**  
 (Specify)

 TIPO - TYPE  
**Radiale**  
 Radial

 USCITA - OUTPUT  
**Porta Pinza**  
 Collet Chuck

 REFRIGERANTE  
 COOLANT  
**25 bar**

 RATIO  
**1:1**

 ROTAZIONE - ROTATION  
**Opposto al mandrino**  
 Opposite to machine spindle

Code	VDI	Output	Int Cool.	I1	H	I3	b1	h1	h2	h3	h4	Nm	Rpm	kw
99.DP.0925	30	ER-25 - Ø1+16	✓	45	55	31	64	56	60	3	52	32	6000	8
99.DP.0926	30	ER-25 - Ø1+16	✓	45	85	31	64	56	60	3	52	32	6000	8
99.DP.0927	30	ER-25 - Ø1+16	✓	45	100	31	64	56	60	3	52	32	6000	8
99.DP.0928	40	ER-32 - Ø2+20	✓	53	100	35	76	71	62	11	71	63	5000	10
99.DP.0929	50	ER-40 - Ø3+30	✓	70	110	44	88	92	73	16	79	100	4000	12
99.DP.0930	60	ER-50 - Ø7+34	✓	83	130	52	110	149	83	46	100	160	3200	15



MODELLI DI TORNIO COMPATIBILI  
COMPATIBLE LATHE TYPES

VDI 20 / VDI 25 / VDI 30 / VDI 50 / VDI 60



Vedi pagine compatibilità 5.10 / 5.13 - See compatibility pages 5.10 / 5.13

**VDI**  
DIN 1809

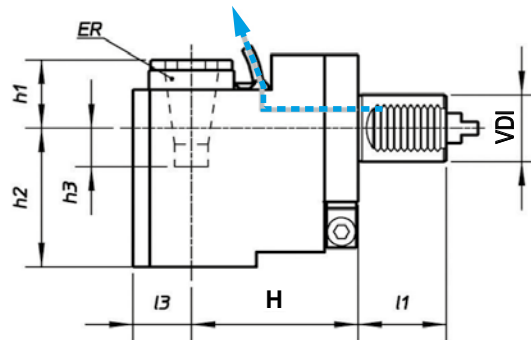

**SINISTRO - LEFT**  
(Standard)

**DESTRO - RIGHT**  
(Specify)

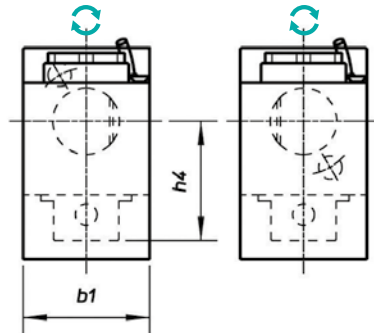

TIPO - TYPE  
**Arretrato**  
Rear Offset



USCITA - OUTPUT  
**Porta Pinza**  
Collet Chuck



REFRIGERANTE  
COOLANT  
**Esterno**  
External



RATIO  
**1:1**



ROTAZIONE - ROTATION  
**Uguale al mandrino**  
Same as machine spindle

Code	VDI	Output	Int Cool.	l1	H	l3	b1	h1	h2	h3	h4	Nm	Rpm	kw
99.DP.0931	20	ER-16 - Ø1+10	NO	35	75	26	50	28	48	4	56	13	6.000	5
99.DP.0932	30	ER-25 - Ø1+16	NO	45	85	31	64	14,5	90	45	52	32	5.000	8
99.DP.0933	40	ER-32 - Ø2+20	NO	53	100	35	76	20	106	40	72,5	63	4.000	10
99.DP.0934	50	ER-40 - Ø3+30	NO	70	110	44	88	31	136	46	79	100	4.000	12

4

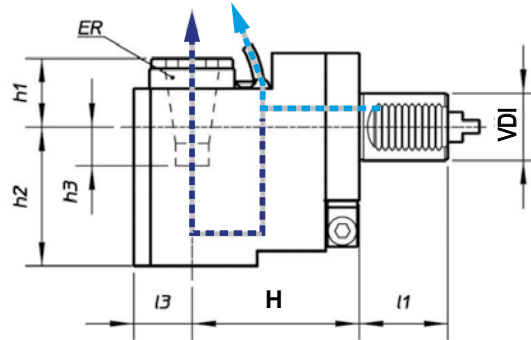

**SINISTRO - LEFT**  
(Standard)

**DESTRO - RIGHT**  
(Specify)

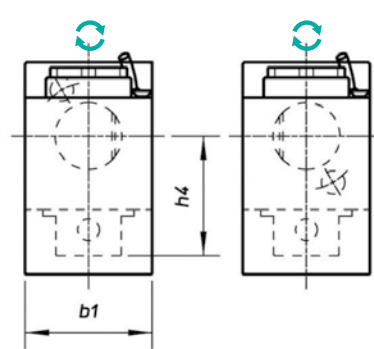

TIPO - TYPE  
**Arretrato**  
Rear Offset



USCITA - OUTPUT  
**Porta Pinza**  
Collet Chuck



REFRIGERANTE  
COOLANT  
**25 bar**



RATIO  
**1:1**



ROTAZIONE - ROTATION  
**Uguale al mandrino**  
Same as machine spindle

Code	VDI	Output	Int Cool.	H	l2	l3	b1	h1	h2	h3	h4	Nm	Rpm	kw
99.DP.0935	30	ER-25 - Ø1+16	✓	85	45	31	64	24	105,5	45,5	52	32	5.000	8
99.DP.0936	40	ER-32 - Ø2+20	✓	100	53	35	76	30	124	40	72,5	63	4.000	10
99.DP.0937	50	ER-40 - Ø3+30	✓	110	70	44	88	44	136	46	79	100	4.000	12

**MODELLI DI TORNIO COMPATIBILI**  
 COMPATIBLE LATHE TYPES

**VDI 20 / VDI 25 / VDI 30 / VDI 50 / VDI 60**

Vedi pagine compatibilità 5.10 / 5.13 - See compatibility pages 5.10 / 5.13

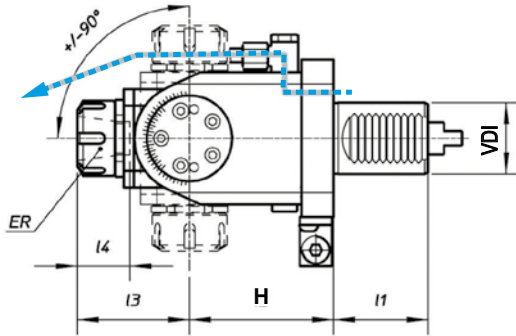
**SINISTRO - LEFT**  
 (Standard)

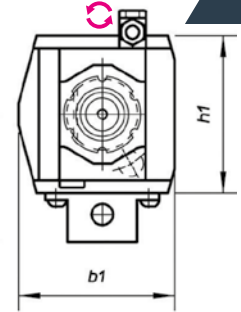
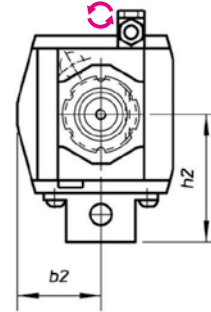
**DESTRO - RIGHT**  
 (Specify)

**VDI**  
**DIN 1809**

 TIPO - TYPE  
 Orientabile  
 Adjustable  $\pm 90^\circ$ 

 USCITA - OUTPUT  
 Porta Pinza  
 Collet Chuck

 REFRIGERANTE  
 COOLANT  
 Esterno  
 External

 RATIO  
 1:1

 ROTAZIONE - ROTATION  
 Opposto al mandrino  
 Opposite to machine spindle

Code	VDI	Output	Int Cool.	I1	H	I3	I4	b1	b2	h1	h2	Nm	Rpm	kw
99.DP.0940	30	ER-20 - $\varnothing 1+13$	NO	45	64	52	37	70	37	64	54	15	6.000	3
99.DP.0941	30	ER-20 - $\varnothing 1+13$	NO	45	97	52	37	70	37	64	54	15	6.000	3
99.DP.0942	40	ER-25 - $\varnothing 1+16$	NO	53	81	63	42	87	47	88	71	25	6.000	4

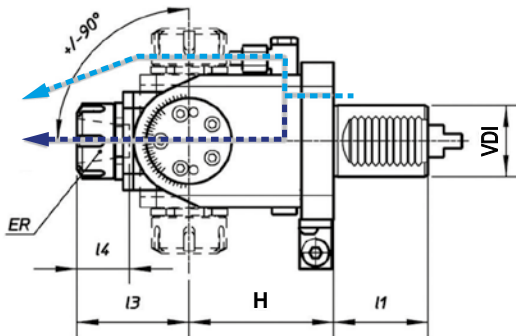
**SINISTRO - LEFT**  
 (Standard)

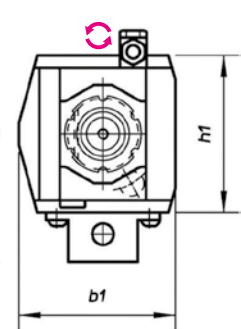
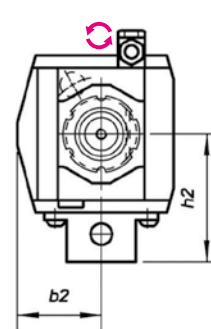
**DESTRO - RIGHT**  
 (Specify)

 TIPO - TYPE  
 Orientabile  
 Adjustable  $\pm 90^\circ$ 

 USCITA - OUTPUT  
 Porta Pinza  
 Collet Chuck

 REFRIGERANTE  
 COOLANT  
 25 bar

 RATIO  
 1:1

 ROTAZIONE - ROTATION  
 Opposto al mandrino  
 Opposite to machine spindle

Code	VDI	Output	Int Cool.	I1	H	I3	I4	b1	b2	h1	h2	Nm	Rpm	kw
99.DP.0943	30	ER-20 - $\varnothing 1+13$	✓	45	64	52	37	70	37	64	54	15	6.000	3
99.DP.0944	30	ER-20 - $\varnothing 1+13$	✓	45	97	52	37	70	37	64	54	15	6.000	3
99.DP.0945	40	ER-25 - $\varnothing 1+16$	✓	53	81	63	42	87	47	88	71	25	6.000	4



PIÙ SEMPLICE / PIÙ INFO / PIÙ PRODOTTI - EASIER / MORE INFO / MORE PRODUCTS

TROVA IL TUO PRODOTTO IN POCHI CLICK - FIND YOUR PRODUCT IN FEW CLICKS

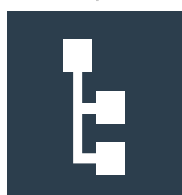

by category



by code



by description



by configurator

## Un nuovo modo facile e veloce per ordinare la tua attrezzatura Gerardi

Il nuovo Gerardi estore offre la possibilità di visualizzare e ordinare qualsiasi articolo Gerardi appartenente alle categorie Workholding o Tooling presente sui nostri listini in modo semplice, veloce e completo. Da ora puoi ordinare la morsa, la testa angolare o il motorizzato che ti interessa direttamente on-line dal nostro estore senza costi aggiuntivi.

## A new quick and easy way to order your equipment branded Gerardi.

The new Gerardi estore offers the ability to view and order any item available on our Workholding and Tooling catalogues with the easiest, fastest and comprehensive way. You can now order the vise, angle head or driven tool of your interest directly online from our store without any additional cost.



WINDOWS / IOS



ANDROID / IPHONE

